



[www.snap4city.org](http://www.snap4city.org)  
[www.snap4solutions.org](http://www.snap4solutions.org)



[www.km4city.org](http://www.km4city.org)

## Developing Smart Applications & Business Intelligence Solutions

Sept. 2024, Course, Part 8

<https://www.snap4city.org/944>

<https://www.snap4city.org/577>

**DIGITAL TWIN SOLUTIONS TO SETUP SUSTAINABLE DECISION SUPPORT SYSTEMS AND BUSINESS INTELLIGENCE**



UNIVERSITÀ  
DEGLI STUDI  
FIRENZE

**DINFO**  
DIPARTIMENTO DI  
INGEGNERIA  
DELL'INFORMAZIONE

**DISIT**  
DISTRIBUTED SYSTEMS  
AND INTERNET  
TECHNOLOGIES LAB



Paolo Nesi, [paolo.nesi@unifi.it](mailto:paolo.nesi@unifi.it)  
<https://www.Km4City.org>  
<https://www.disit.org>



Be smart in a SNAP!



Developing Smart Applications  
& Business Intelligence Solutions

Sept. 2024, Course, Part 8  
<https://www.snap4city.org/944>  
<https://www.snap4city.org/577>

SCALABLE SMART ANALYTIC APPLICATION BUILDER FOR SENTIENT CITIES



UNIVERSITÀ  
DEGLI STUDI  
FIRENZE

DINFO  
DIPARTIMENTO DI  
INGEGNERIA  
DELL'INFORMAZIONE

DISIT  
DISTRIBUTED SYSTEMS  
AND IT INFRASTRUCTURES  
LAB





# Digital Twin Solutions for Sustainability

OPERATION AND PLAN - CONTROL ROOMS - DECISION SUPPORT SYSTEMS - WHAT-IF ANALYSIS - OPTIMIZATION - APPLICATIONS

### CONTROL AND PLAN

### MOBILITY AND TRANSPORT

### SMART ENERGY AND SMART BUILDING

### ENVIRONMENT AND WASTE MANAGEMENT

### CITY USER'S SERVICES AND TOURISM MANAGEMENT

- DEVELOPMENT ENVIRONMENT AND METHODOLOGY
- VISUAL PROGRAMMING, ML, AI, HPC
- TRAINING COURSES
- LIVING LABS
- GUI CUSTOM STYLES
- FULL APPLICATIONS, DASHBOARDS AND VIEWS
- MOBILE APPS



## VISUAL ANALYTICS - SYNOPTICS - GRAPHICAL WIDGETS - ANALYTICS - BUSINESS INTELLIGENCE - SIMULATIONS

### DASHBOARDS, WIDGETS TEMPLATES

### PREDICTION - ANOMALY DETECTION - CLUSTERING - ROUTING - SENTIMENT NLP - TRAFFIC FLOW - PEOPLE FLOWS - SDG

15 MIN CITY INDEX - KPI - HEATMAPS - ORIGIN DESTINATION - ETC...

### API - MICROSERVICES - GIS - BPM VIDEO - REPORTS - MAPS - 3D ...

### EXPERT SYSTEM, KNOWLEDGE BASE SEMANTIC REASONING SMART DATA MODEL IOT DEVICE MODELS, STORAGE

### BIG DATA ANALYTICS, ARTIFICIAL INTELLIGENCE EXPLAINABLE AI, MACHINE LEARNING, GENERATIVE AI OPERATIVE RESEARCH, STATISTICS

### VISUAL PROGRAMMING, ADAPTERS DATA FLOWS, WORKFLOWS PARALLEL DISTRIBUTED PROCESSING DATA DRIVEN

FULL INTEROPERABILITY, ANY: DATA, BROKERS, NETWORKS AND VERTICALS

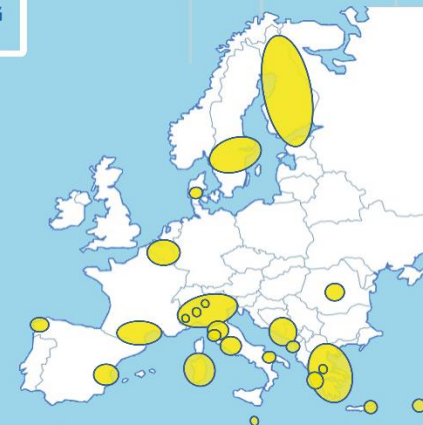

Powered by FIWARE

FREE TRIAL

PEN Test Passed

EU GDPR COMPLIANT

SNAP4 Appliances and Dockers Installations

EUROPEAN OPEN SCIENCE CLOUD

Node-RED

JS Foundation

E015 digital ecosystem

NVIDIA

# Digital Twin Development Platform

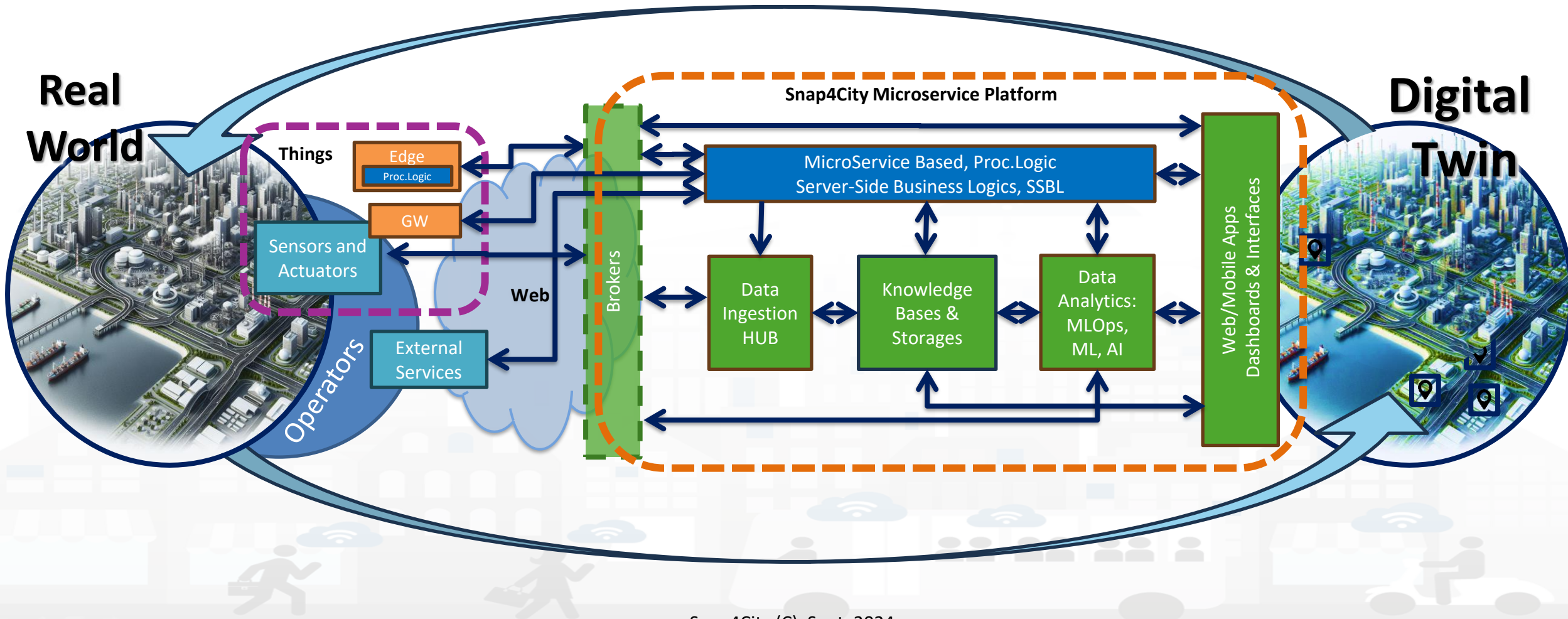

<https://www.snap4city.org/944>



*On Line Training Material (free of charge)*

1st part	2nd part	3rd part	4th part	5th part	6th part	7th part	8th
Overview	Dashboards	IOT App, IOT Network	Data Analytics	Data Ingestion processes	System and Deploy Install	Smart City API: Web & Mob. App	Design and Develop Smart Solutions

# Part 1: Overview for researchers and developers

Part 1: Overview for  
researchers / developers

SLIDES



- Objectives and Tasks, architecture and Digital Twin
- Monitoring and Control: Mobility, Humans, Engagement, ..
- Decision Support Systems, planning, what-if and optimization
  - Data Analytics, Artificial Intelligence, XAI, ML
  - Traffic Light Plan Optimisation
  - Traffic Infrastructure Optimization
- Industry Domain: predictive maintenance
  - Autoclave Cycle: Energy Optimisation
- Developing on Snap4City platforms
- Training Suggestion and publications / further reading
- Development Costs Advantages
- Accelerating on Smart City Deploy with Snap4City
- Platform Administration

# Part 1: Overview for adopters, city, etc.

Part 1: Overview for  
adopters city/industry

[SLIDES](#)

[Interactive Slides](#)



- Needs of the Operators vs platform
- Platform Overview: from data to interactive tools
- Data Analytics, Artificial Intelligence
- Some Cases by Domains: solutions vs analytics
- Other Cases and scenarios
- Overview of the next parts of the Course
- References to other training material

## Part 2: Dashboard production and management

Part 2: Dashboards  
production and  
management

[SLIDES](#)

[Interactive Slides](#)



- Recall on Snap4City Architecture
- Dashboards Purposes and Uses
- Main Data Kinds: data vs representations
- Dashboards Main Concepts and simple Widgets
- Creating a Snap4City Dashboard, wizard
- Multi Data Map Widget
- High Level Types, video, external services, synoptics
- Selector for the Multi Data Map Widget
- Data Inspector vs Data Processes Details
- Dashboard Management



## Part 3: IoT App, process logic, server side BL

- Recall on Snap4City Architecture
- Node-RED
- IOT App = Node-RED + Snap4City
  - IoT App === Proc.Logic
- Examples of IOT App for Smartening Solutions
- Exploiting/Generating data by using: IoT App/Proc.Logic
- External Service <-> IoT App/Proc.Logic
- Dashboards <-> IoT App/Proc.Logic
  - Server Side Business Logic
- training material

Part 3: IOT App, Process  
Logic, Server Side  
Business Logic

[SLIDES](#)

[Interactive Slides](#)



# Part 4: Data Analytics

Part 4: Data Analytics  
and Artificial  
Intelligence

[SLIDES](#)

[Interactive Slides](#)



- Why and Where use DA, AI and XAI -> General Life Cycle, scenario editor, monitoring and control
- Data Processing: KPI, traffic, emissions, public transport quality, ..
- From Data Analytics, DA to Artificial Intelligence, AI
- List of the most relevant available DA and AI Solutions
- Predictions and Anomaly detections: parking, biking, NOx, landslide, people
- Computing: Higher Level Types Data and their representations: traffic, heatmaps, 3D
- Human Behavior, Engagement, Typical Time trends, WIFI sniffing
- Using AI in main domains: Mobility and transport, traffic optimization, Smart Energy, Smart Building,
- How AI/XAI, and Life Cycle, AI/ML requirements, XAI,
- Using DA, AI/XAI in Snap4City infrastructures
  - Data Analytics <-> IoT App / Proc.Logic
  - MLOps, ClearML, exploiting clusters of GPU/CPU
- Decision Support Systems and What-If Analysis, transport offer, DORAM tool
- Routing, Multimodal Routing, Dynamic Routing
- Predictive Maintenance
- Training Material

# Part 5: Data Ingestion and Interoperability

Part 5: Data Ingestion  
and Interoperability

[SLIDES](#)

[Interactive Slides](#)

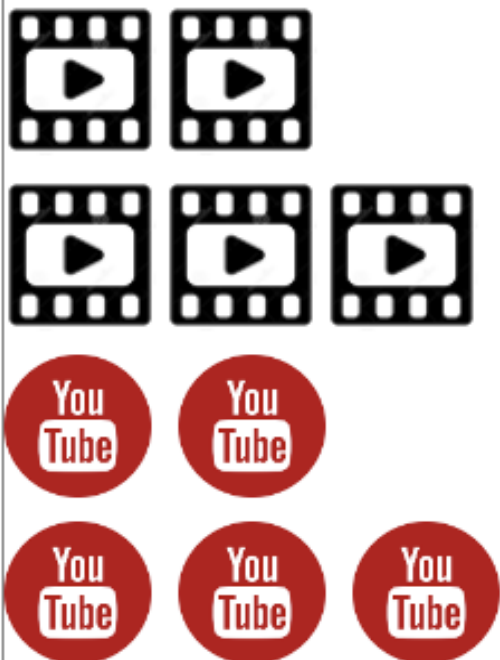

- When Solutions and tools for Data Ingestion and Interoperability are needed
- Overview of Snap4City Data Storage and Stack
- Knowledge Base: Modelling and Setting Up
- High Level Types vs Ingestion Process
- Data Ingestion Strategy and Orientation
- Ingestion of Points of Interest with POI Loader
- Models vs Devices/Entities and Registration
- Verification of Data Ingestion
  - Digital Twin Data Inspector vs Data Processes Details
  - My Data Dashboard Dev to assess data on Open Search Storage
- An Integrated Example for Time Series
- Entities Ingestion with Data Table Loader
- High Performance Ingestion via Python
- FIWARE Smart Data Models on Snap4City
- Ingestion of MyKPI with Proc.Logic / IoT App

# Part 6: Platform Architecture, interop and Deploy

Part 6: Snap4City  
Platform Architecture,  
Interoperability,  
Management and  
Deploy

[SLIDES](#)

[Interactive Slides](#)



- Snap4City Architecture
- Interoperability of Snap4City Platform
- Interoperability with respect to Hardware staff
- Adding Features and Modules to Snap4City
- FIWARE and Snap4City
- Snap4City vs State of the Art Solutions
- Smart City planning with Snap4City Team Support
- The Role of the Living Lab Support
- Snap4City Platform: Administration Overview
- Snap4Tech: Smart Solutions as a Service
- Deploy Snap4Tech solutions: Docker Based

# Parts 7 & 8: API, Mobil, Business Intelligence

Part 7: Exploiting  
Snap4City API, and  
Web/Mobile  
Applications SDK

[SLIDES](#)

[Interactive Slides](#)



Part 8: Developing  
Smart Applications &  
Business Intelligence  
Solutions

[SLIDES](#)

[Interactive Slides](#)



- **Smart City API: Internal and External**
- Concepts and tools for using Knowledge Base, ServiceMap, API
- Federated Knowledge Bases and Smart City APIs
- **Advanced Smart City API**
- Access to Protected data
- **Forging and managing: Mobile and Web Apps, MicroApplications**
- **Web and Mobile App Development Kit**
- -----
- Developing in the smart city IoT/WoT context
- Smart Solutions Development Life Cycle
- Analysis for Innovation (Co-Creation and Co-Working)
- Design: Data, Data Models, Data Relationships
- Design & Develop: Data Processes Proc.Logic / IoT App
- Design & Develop of Data Analytics
- Design & Develop: user interfaces, visual tools
- Visual Analytic vs Data Analytics: Client Side Business Logic Intelligence
- Design and Control of Smart Applications
- What is missing here and you can get from former course

# Snap4City Training vs Targets

- **Estimate Indicators: P1, P2, P3, P4, P5**
  - IoT App/Proc.Logic JavaScript, Data Analytics, Dashboards to see data and results
- **Load additional data: P1, P2, P3, P5**
  - IoT App/Proc.Logic JavaScript, IoT Directory, ServiceMap, advanced interoperability, Dashboards to see them
- **Performing AI/XAI on accessible data: P1, P2, P3, P4, P5 (P8)**
  - IoT App/Proc.Logic JavaScript, ServiceMap, ASCAPI, Python, Dashboards to see data/results
- **Developing Business intelligence: P1, P2, P3, P7, P8**
  - IoT App/Proc.Logic JavaScript, Dashboards to see them, ASCAPI, CSBL for making them intelligent, JavaScript
- **Developing Web and Mobile Apps: P1, P2, P3, P7, P8**
  - ServiceMap, ASCAPI, Dashboards
- **Deploy, install, test and management: P1, P2, P3, P6**
  - IoT App/Proc.Logic JavaScript, ServiceMap, Dashboards to see them

# Note on Training Material

- **Course 2023:** <https://www.snap4city.org/944>
  - Introductionary course to Snap4City technology
- **Course** <https://www.snap4city.org/577>
  - Full training course with much more details on mechanisms and a wider set of cases/solutions of the Snap4City Technology
- **Documentation** includes a deeper round of details
  - Snap4City Platform Overview:
    - <https://www.snap4city.org/drupal/sites/default/files/files/Snap4City-PlatformOverview.pdf>
  - Development Life Cycle:
    - <https://www.snap4city.org/download/video/Snap4Tech-Development-Life-Cycle.pdf>
  - Client Side Business Logic:
    - <https://www.snap4city.org/download/video/ClientSideBusinessLogic-WidgetManual.pdf>
- **On line cases and documentation:**
  - <https://www.snap4city.org/108>
  - <https://www.snap4city.org/78>
  - <https://www.snap4city.org/426>

# Tech Overview

- <https://www.snap4city.org/drupal/sites/default/files/files/Snap4City-PlatformOverview.pdf>



### Technical Overview

From: DINFO dept of University of Florence, with its  
DISIT Lab, <https://www.disit.org> with its Snap4City solution

Snap4City:

- Web page: <https://www.snap4city.org>
- <https://twitter.com/snap4city>
- <https://www.facebook.com/snap4city>

Contact Person: Paolo Nesi, [Paolo.nesi@unifi.it](mailto:Paolo.nesi@unifi.it)

- o Phone: +39-335-5668674
- o LinkedIn: <https://www.linkedin.com/in/paolo-nesi-849ba51/>
- o Twitter: <https://twitter.com/paolonesi>
- o FaceBook: <https://www.facebook.com/paolo.nesi2>



# Development

<https://www.snap4city.org/download/video/Snap4Tech-Development-Life-Cycle.pdf>



## Development Life-Cycle

<https://www.snap4city.org/download/video/Snap4Tech-Development-Life-Cycle-v1-1.pdf>

### From Snap4City:

- We suggest you to read the **TECHNICAL OVERVIEW**:
  - <https://www.snap4city.org/download/video/Snap4City-PlatformOverview.pdf>
- <https://www.snap4city.org>
- <https://www.snap4solutions.org>
- <https://www.snap4industry.org>
- <https://twitter.com/snap4city>
- <https://www.facebook.com/snap4city>
- <https://www.youtube.com/channel/UC3tAO09EbNba8f2-u4vandg>

**Coordinator:** Paolo Nesi, [Paolo.nesi@unifi.it](mailto:Paolo.nesi@unifi.it)

DISIT Lab, <https://www.disit.org>  
DINFO dept of University of Florence,  
Via S. Marta 3, 50139, Firenze, Italy  
Phone: +39-335-5668674

## Development Life Cycle vs Micro X

- Please be careful that not all features listed in the training are available on the Micro X installations.
- The list of modules and features is reported in the Micro X installation page.
- In the Development Life Cycle, the features and modules which are typically not accessible on the first Micro X installation are listed as Optional. In any case, it depends on your specific installation, since you may have requested features out of the standard ones.

# Client Side Business Logic

<https://www.snap4city.org/download/video/ClientSideBusinessLogic-WidgetManual.pdf>



## Client-Side Business Logic Widget Manual

### From Snap4City:

- We suggest you read <https://www.snap4city.org/download/video/Snap4Tech-Development-Life-Cycle.pdf>
- We suggest you read the TECHNICAL OVERVIEW:
  - <https://www.snap4city.org/download/video/Snap4City-PlatformOverview.pdf>
- slides go to <https://www.snap4city.org/577>
- <https://www.snap4city.org>
- <https://www.snap4solutions.org>
- <https://www.snap4industry.org>
- <https://twitter.com/snap4city>
- <https://www.facebook.com/snap4city>
- <https://www.youtube.com/channel/UC3tAQ09EbNba8f2-u4vanda>

Coordinator: Paolo Nesi, [Paolo.nesi@unifi.it](mailto:Paolo.nesi@unifi.it)  
DISIT Lab, <https://www.disit.org>  
DINFO dept of University of Florence,  
Via S. Marta 3, 50139, Firenze, Italy  
Phone: +39-335-5668674



# Free Trial

- Register on [WWW.snap4city.org](http://WWW.snap4city.org)
  - Subscribe on **DISIT Organization**
- **You can:**
  - Access on basic Tools
  - Access to a large volume of Data
  - Create Dashboards
  - Create IOT Applications
  - Connect your IOT Devices
  - Exploit Tutorials and Demonstrations

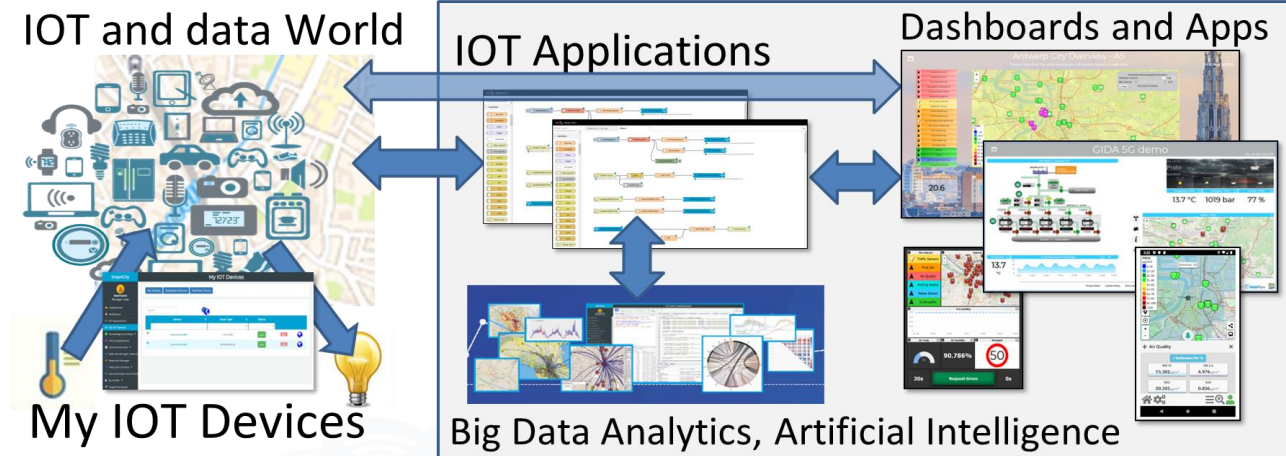

*IF you need to go more in deep you can ask us to pass at the next Role becoming full AreaManager with full rights of development, also for Data Analytics, machine learning, etc.*

# Agenda of Part 8

- **Developing** in the smart city IoT/WoT context
- Smart Solutions **Development Life Cycle**
- **Analysis** for Innovation (Co-Creation and Co-Working)
- **Design**: Data, Data Models, Data Relationships
- **Design & Develop**: Data Processes Proc.Logic / IoT App
- **Design & Develop** of Data Analytics
- **Design & Develop**: user interfaces, visual tools
- **Visual Analytic vs Data Analytics**: Client Side Business Logic Intelligence
- **Design and Control** of Smart Applications
- What is missing here and you can get from former course









# Phases' Coverage

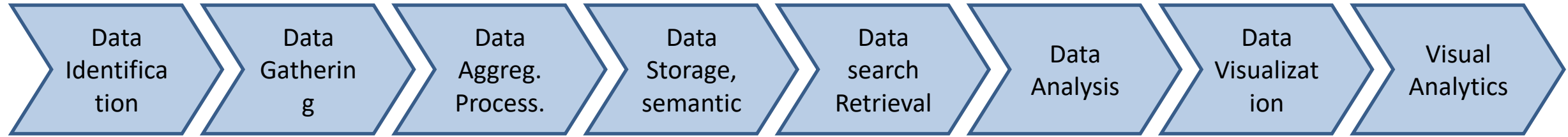

what	Identi- fication	Gatheri- ng	Comple- x data types	Aggrega- tion	Storage (seman- tic)	Efficient Retrieval	Semantic Modeling, query	Data Analytics (micro, marco)	Scenarios context	Artificial Intelligen- ce	Data renderin- g	Real Time Dashboar- d	Event Driven data rendering
GeoServer					(x)						(x)	(x)	
GIS			(x)					(micro)			x		
PowerBI						x		(x)			x	x	
Tableau					x	x		(x)			x	x	
....													
Snap4City	x	x	x	x	x	x	x	x	x	x	x	x	x

# Main Tasks

- **Controlling Status:** management, and operational
  - Monitoring via KPI
  - Computing predictions data from the field and KPI
  - Anomaly detection
  - Early warning on critical conditions
- **Making plan: tactic and strategic, medium and long range**
  - Optimisation: Prescriptions, suggestions
  - Risk assessment
  - What-if analysis on scenarios
    - Simulation and predictions
  - Resilience
- **Be ready for Unexpected Unknowns**

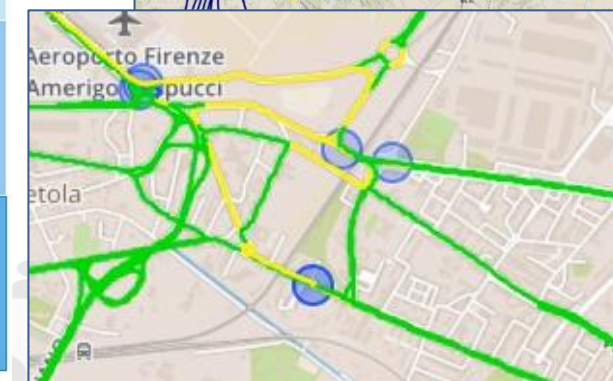
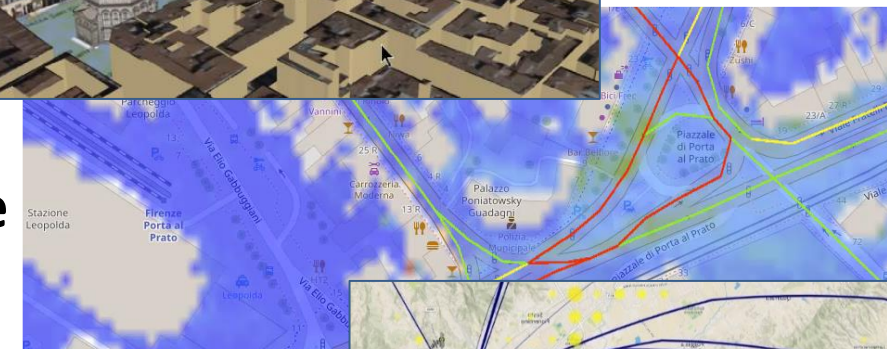





Monitoring

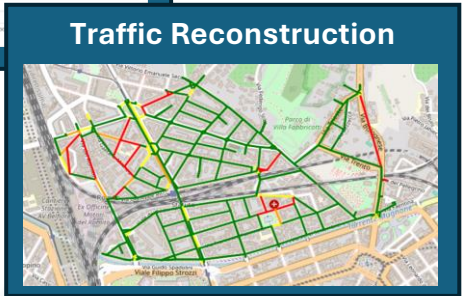
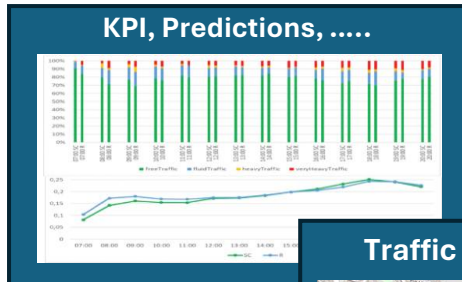

Digital Twin  
Models &  
Data

Predictions,  
Anomaly Detection,  
Analysis, Assessment  
Warning

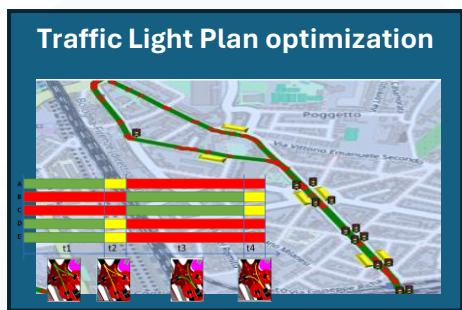

Decision  
Support System

Scenarios

Simulations,  
TFR, Crossroad,  
Public Transport,  
Routing, ..

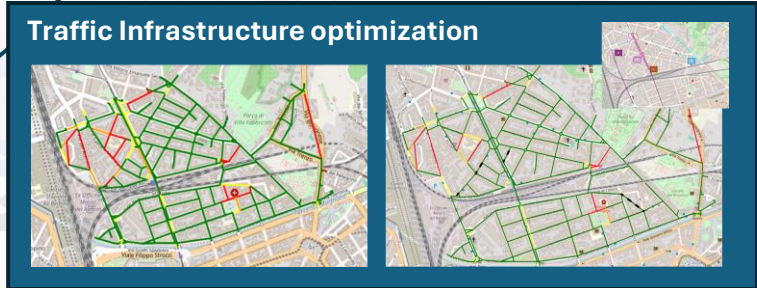

What-If Analysis,  
Optimization

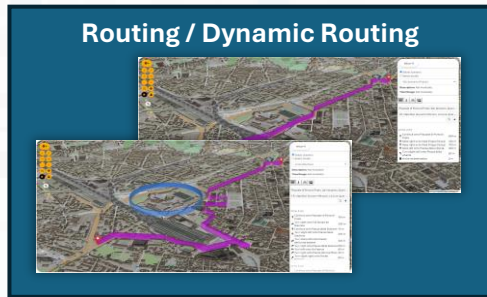
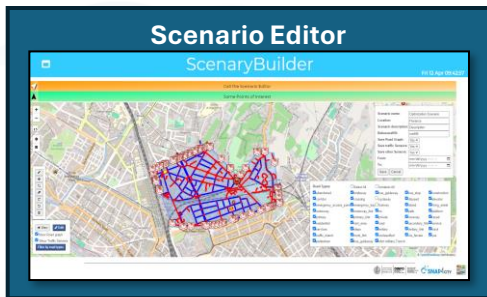

# Digital Twin Development Platform

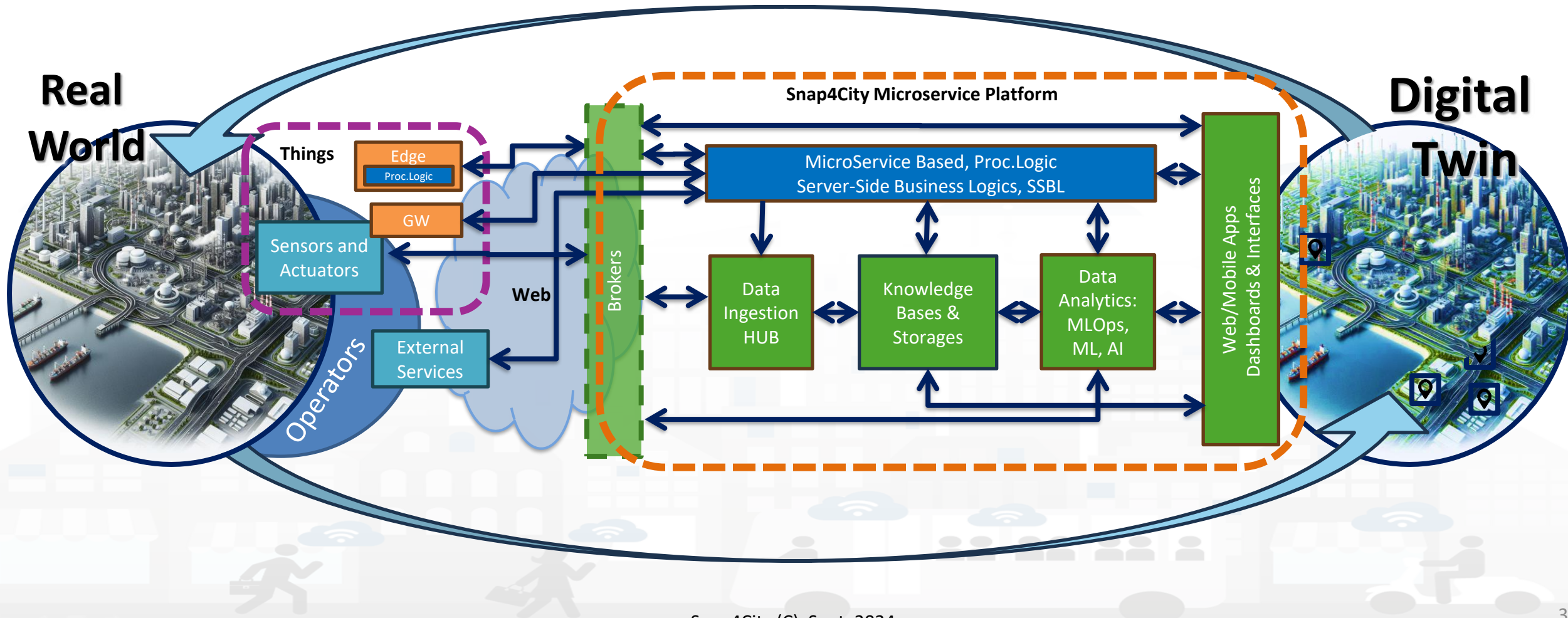

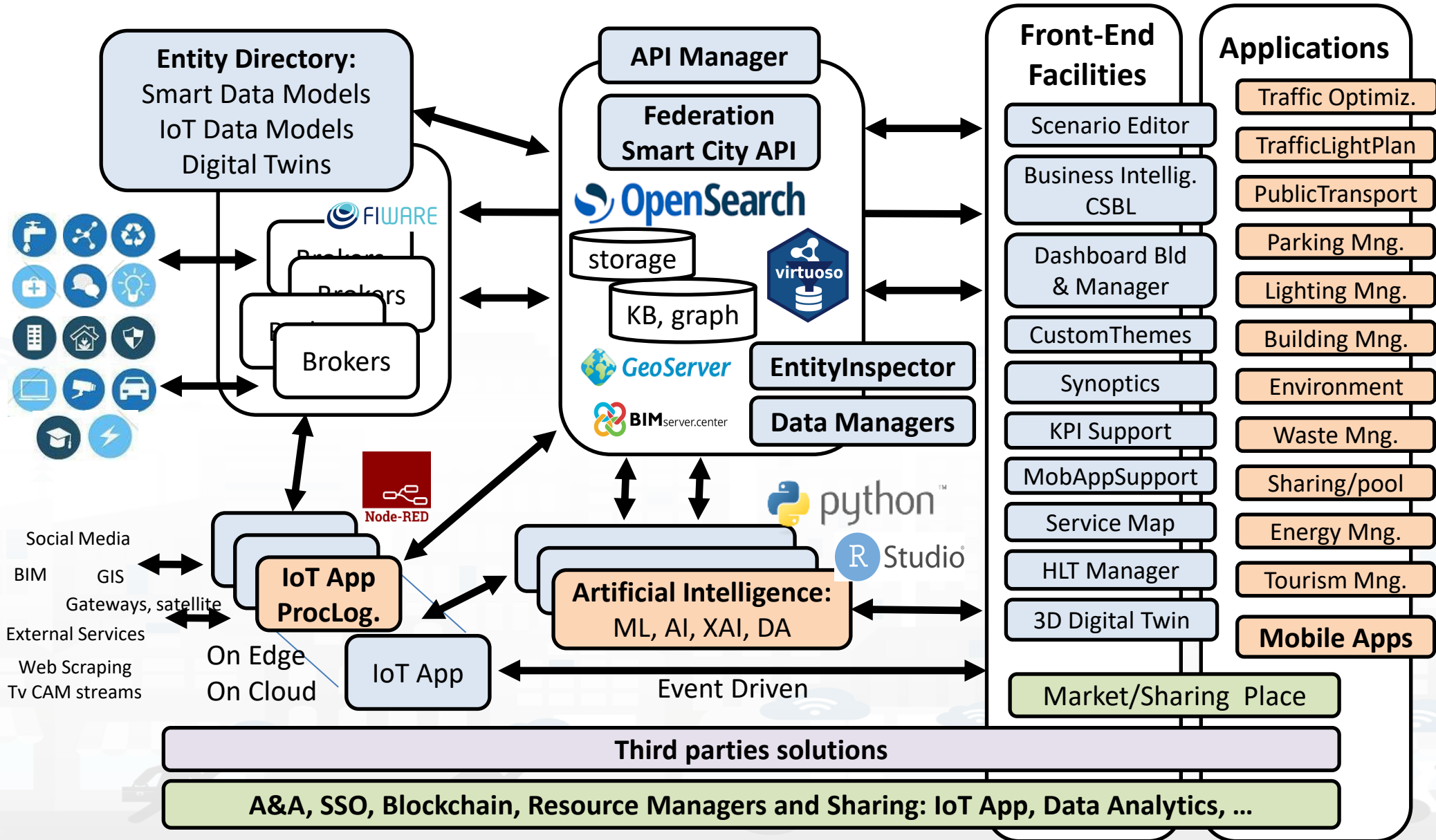

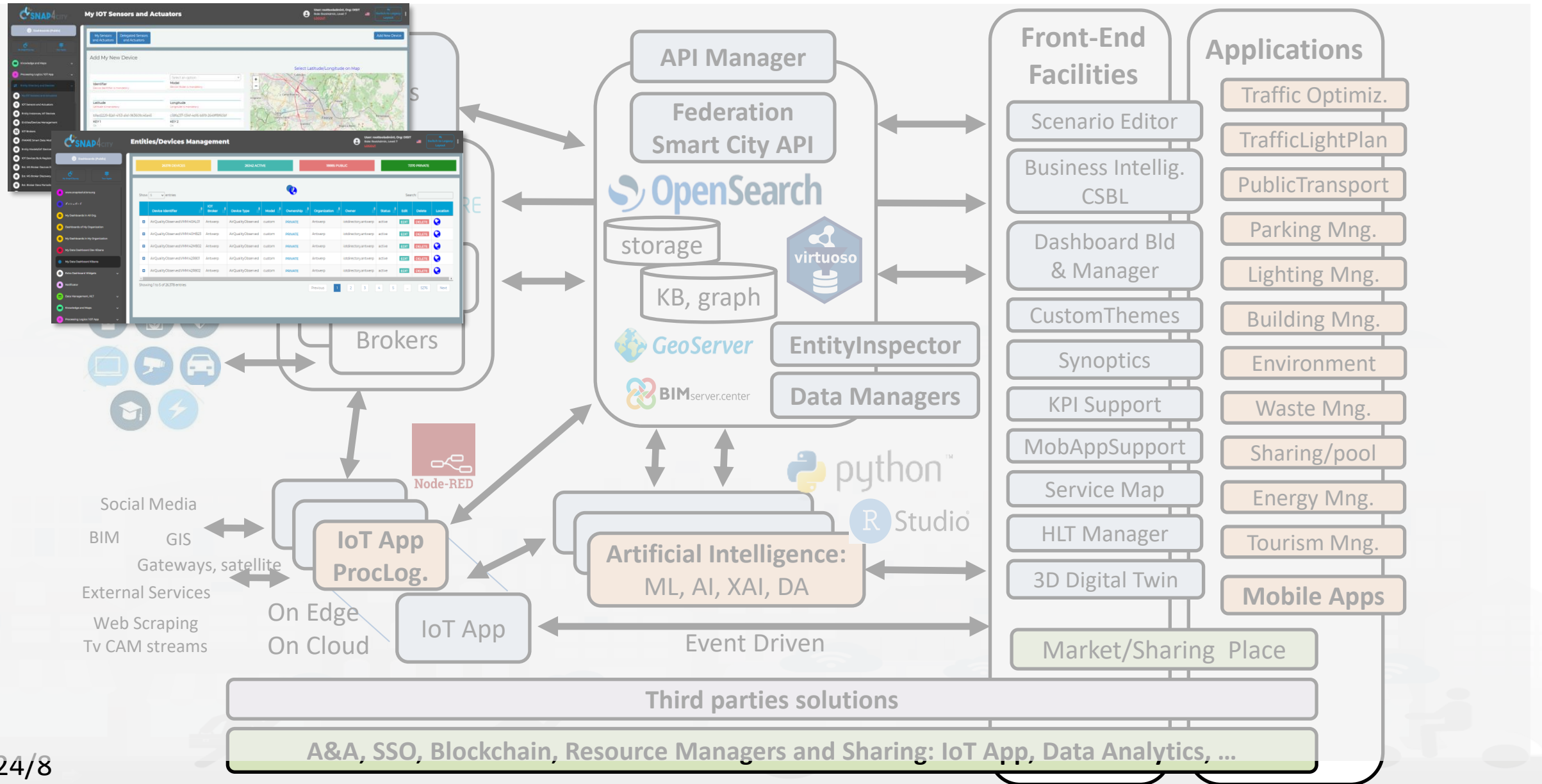

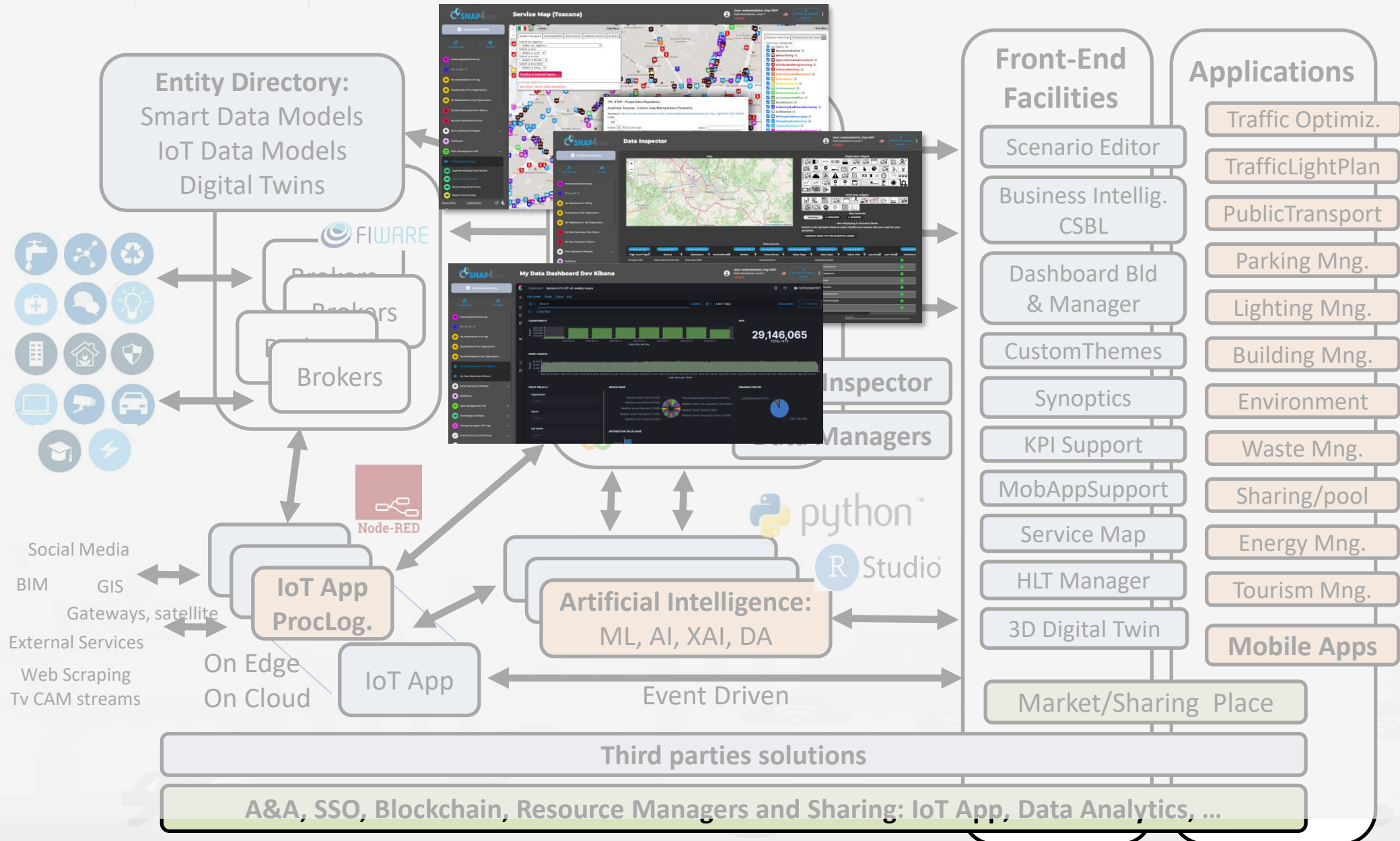



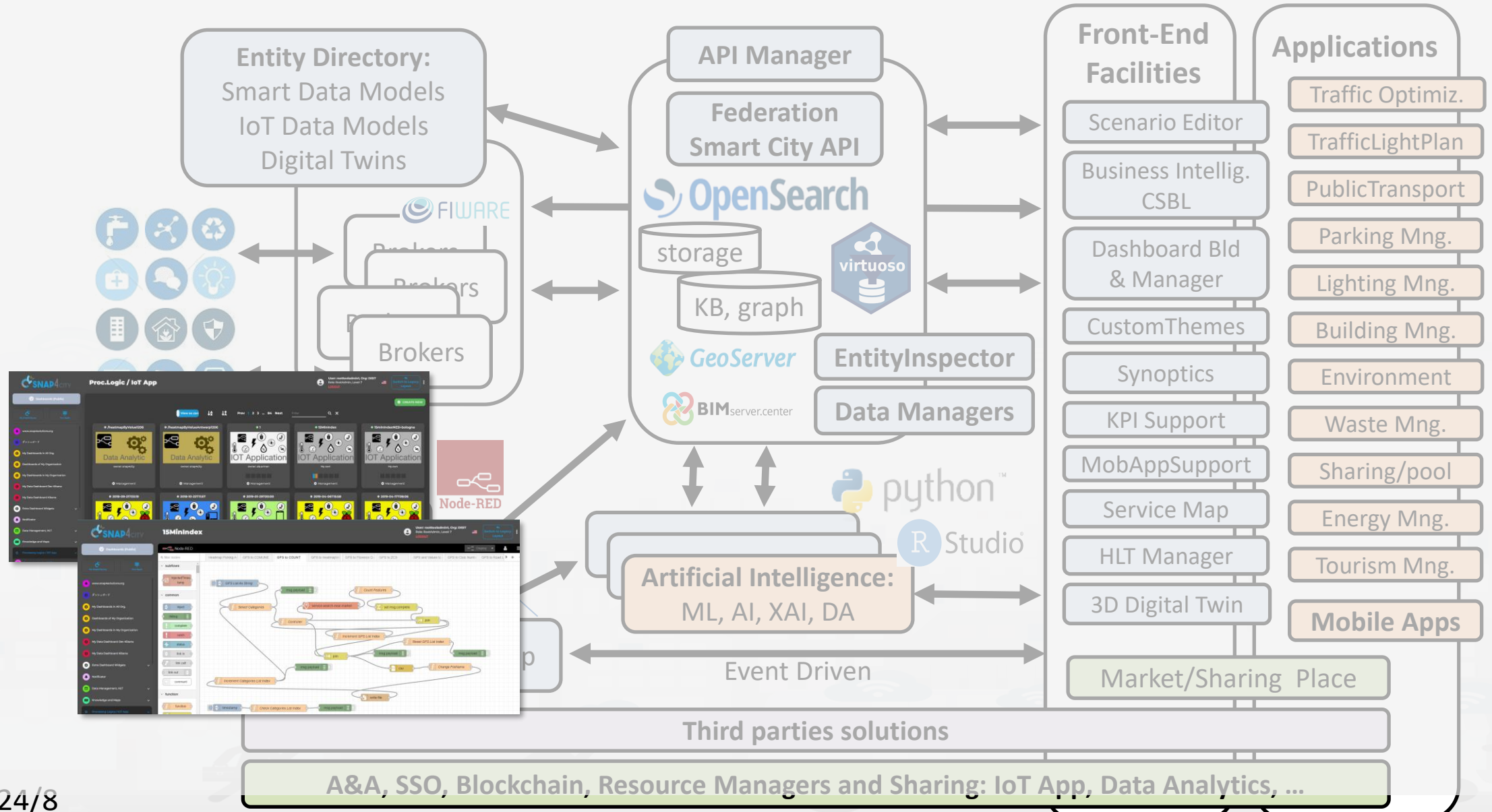

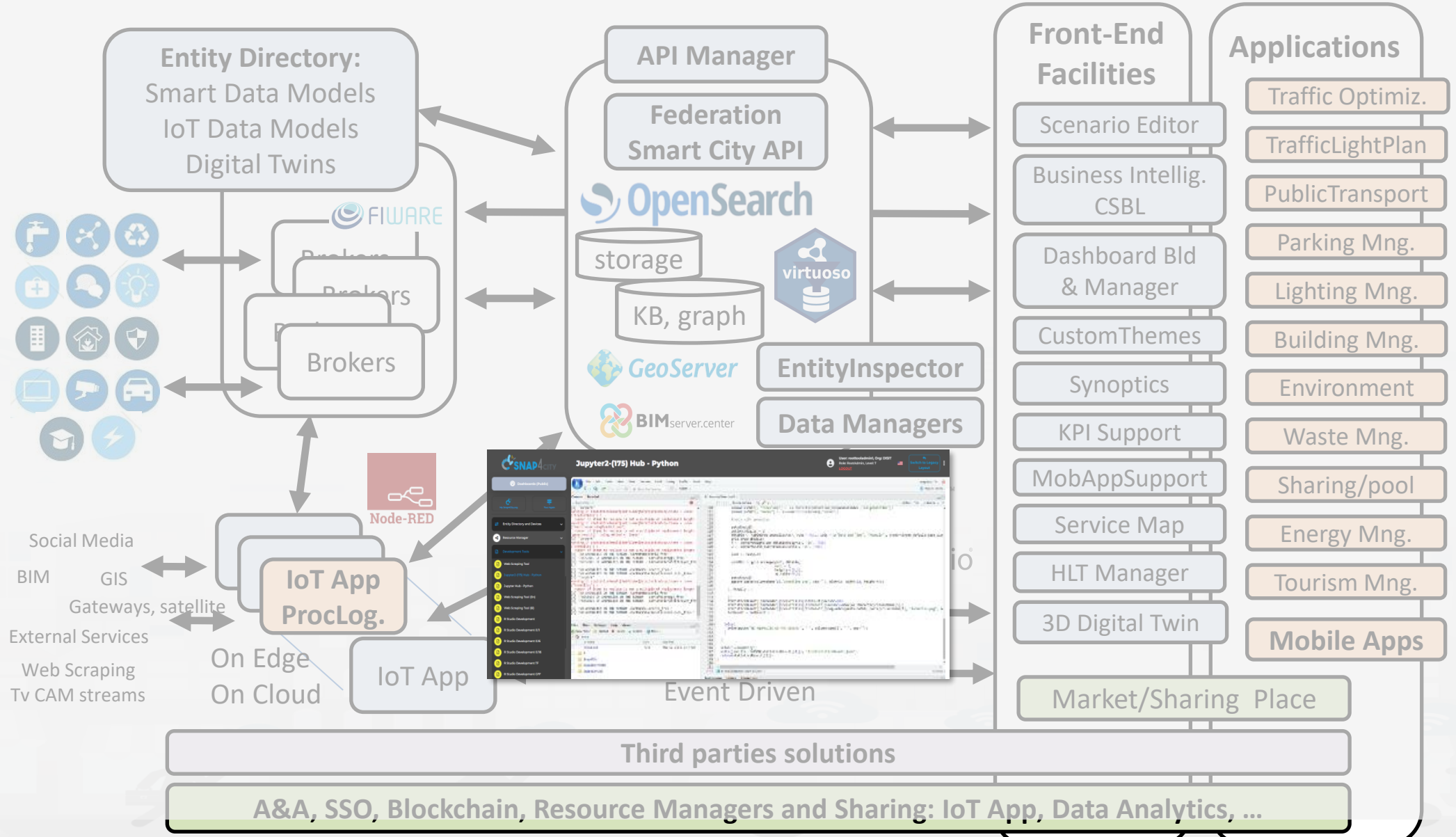

# Tech Arch

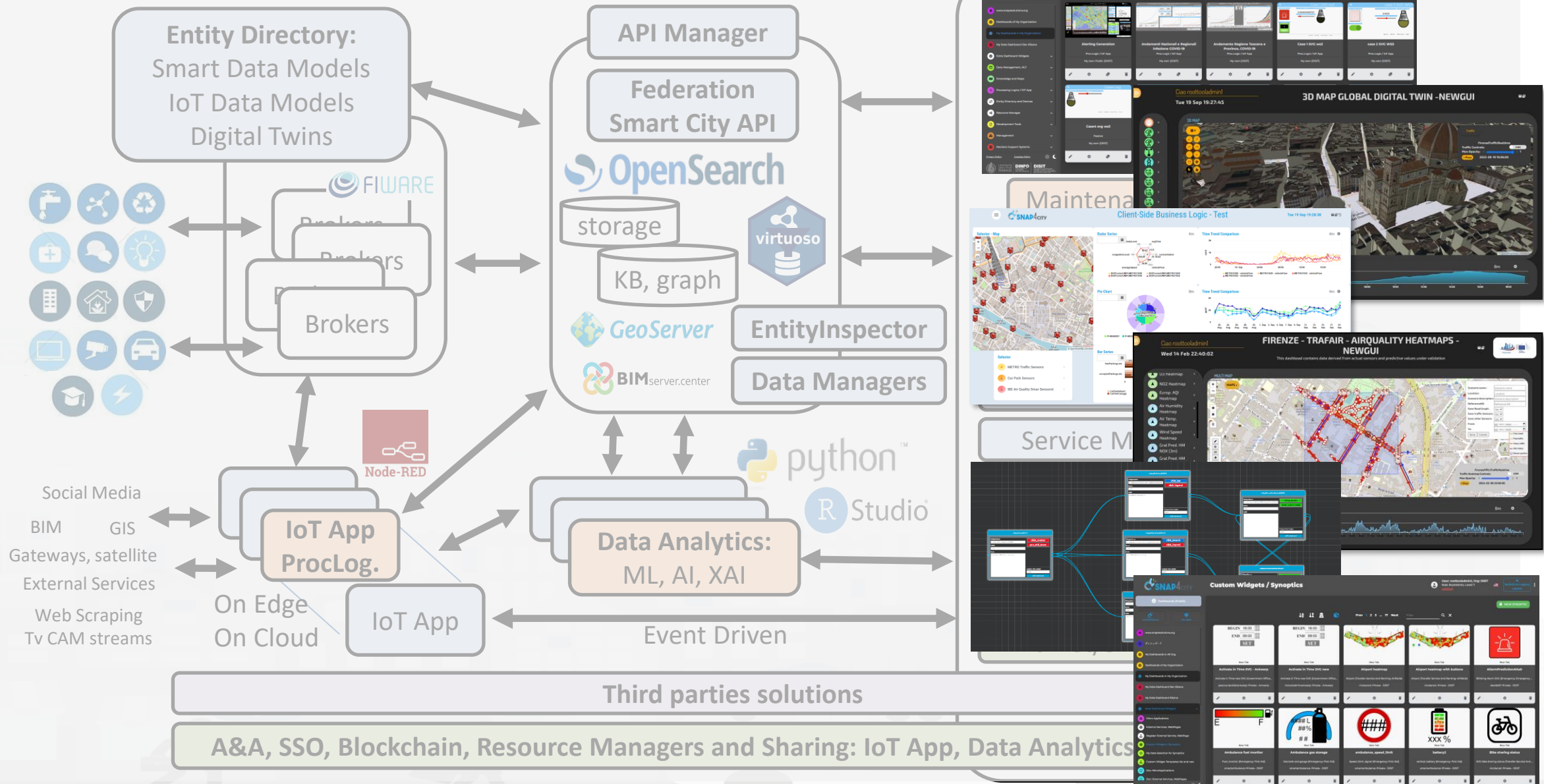

# Visual Development Tools



My IOT Sensors and Actuators

Add My New Device

Entities/Devices Management

ID	NAME	TYPE	STATUS	LOCATION
...	...	...	...	...

Service Map (Toscana)

Data Inspector

My Data Dashboard Dev Kibana

29,146,065

Proc.Logic / IoT App

ISMinIndex

Jupyter2-(775) Hub - Python

My Dashboards in My Organization

3D MAP GLOBAL DIGITAL TWIN - NEWGUI

Client-Side Business Logic - Test

FIRENZE - TRAFFAIR - AIRQUALITY HEATMAPS - NEWGUI

Custom Widgets / Synoptics

Maintenance Inspector managers

Service M

Third parties solutions

A&A, SSO, Blockchain, Resource Managers and Sharing: IoT App, Data Analytics

- **Smart Applications can be easily developed exploiting the cloud infrastructure by producing only:**
  - **Processing Logic / IoT App** with almost no coding activities
  - **Data Analytics** in Python or Rstudio
  - **Dashboards** with almost no coding activities.
- **→ Orange parts of the previous figure slide are those usually developed,**
  - all the rest, is part of the provided microservices and infrastructure.
- **Third party applications can dialog with the solutions via**
  - **Smart City API**, Swagger: <https://www.km4city.org/swagger/external/> and internal for some...
  - **Brokers/IoT Brokers**, for example for NGSI Orion Broker:  
<https://www.km4city.org/swagger/external/?urls.primaryName=Orion%20Broker%20K1-K2%20Authentication%20API>
  - **Processing Logic / IoT App** any protocols: <https://www.snap4city.org/65> They can also expose some specific API, custom made

# Your Applications and IPR in Snap4City

- **Data Models:** Entity Models / IoT Device Models, Smart Data Models, etc.
- **Proc.Logic / IoT App:** data ingestion, adapter, transformation, wrappers, business logic, transcoding, integration, interoperability, algorithms, etc.
- **Data Analytics:** algorithm and processing in RStudio or Python, ML, AI, XAI, etc.
- **User Interface Design:** Dashboards, client-side business logic, Synoptics, widgets, templates, styles, etc.
- **Client-Side Business Logics (if any)** realized in JavaScript on Dashboard widgets.
- **Server-Side Business Logics (if any)** realized in Processing Logic as Node-RED and JavaScript.
- and the **data instances** for the High-Level Types.

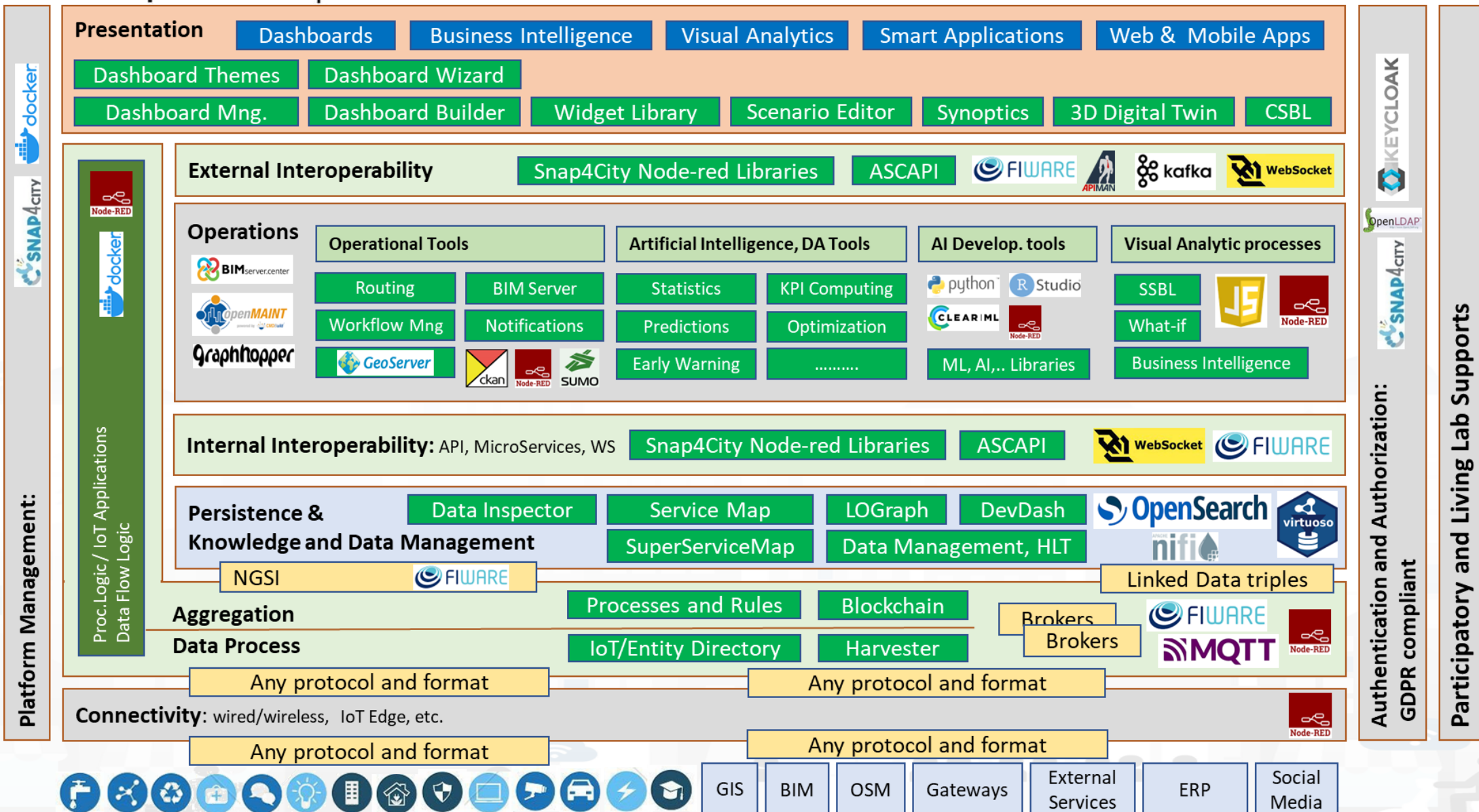

TOP

# Smart Solutions Development Life Cycle

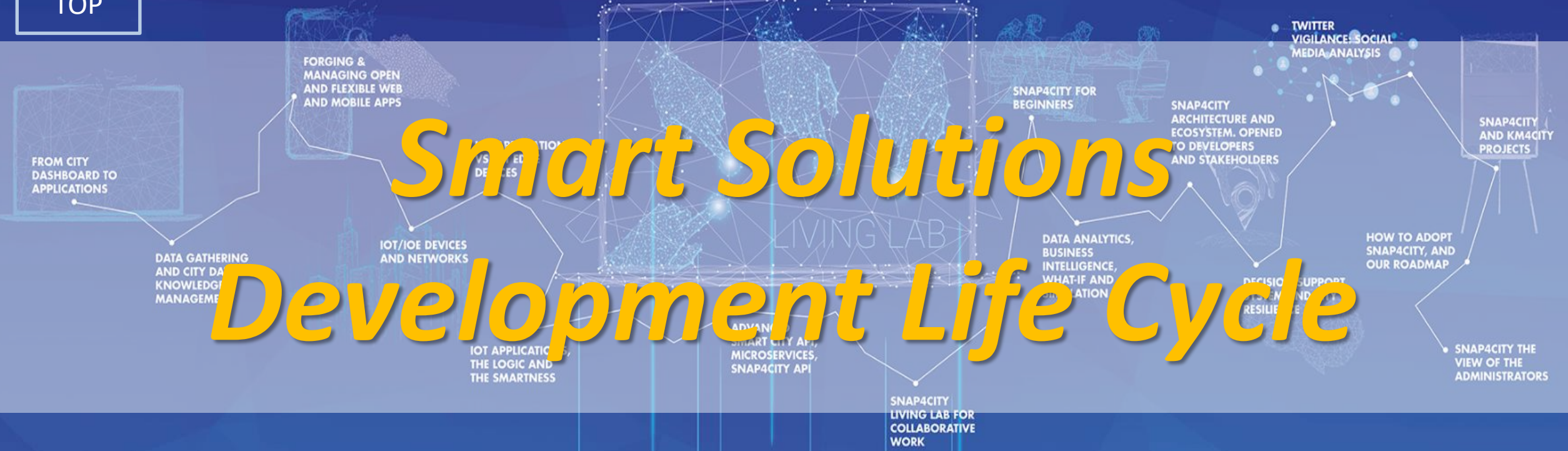





# Development Life Cycle Smart Solutions Agile: CD-CI, Continuous Dev – Continuous Improvement

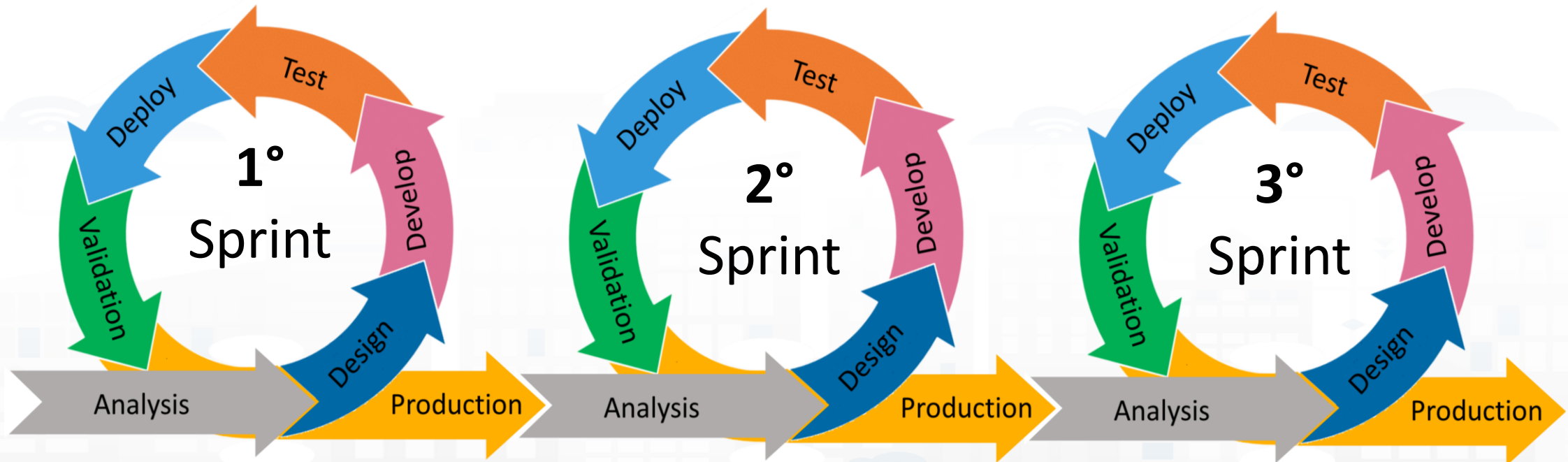

# Development Life Cycle Smart Solutions

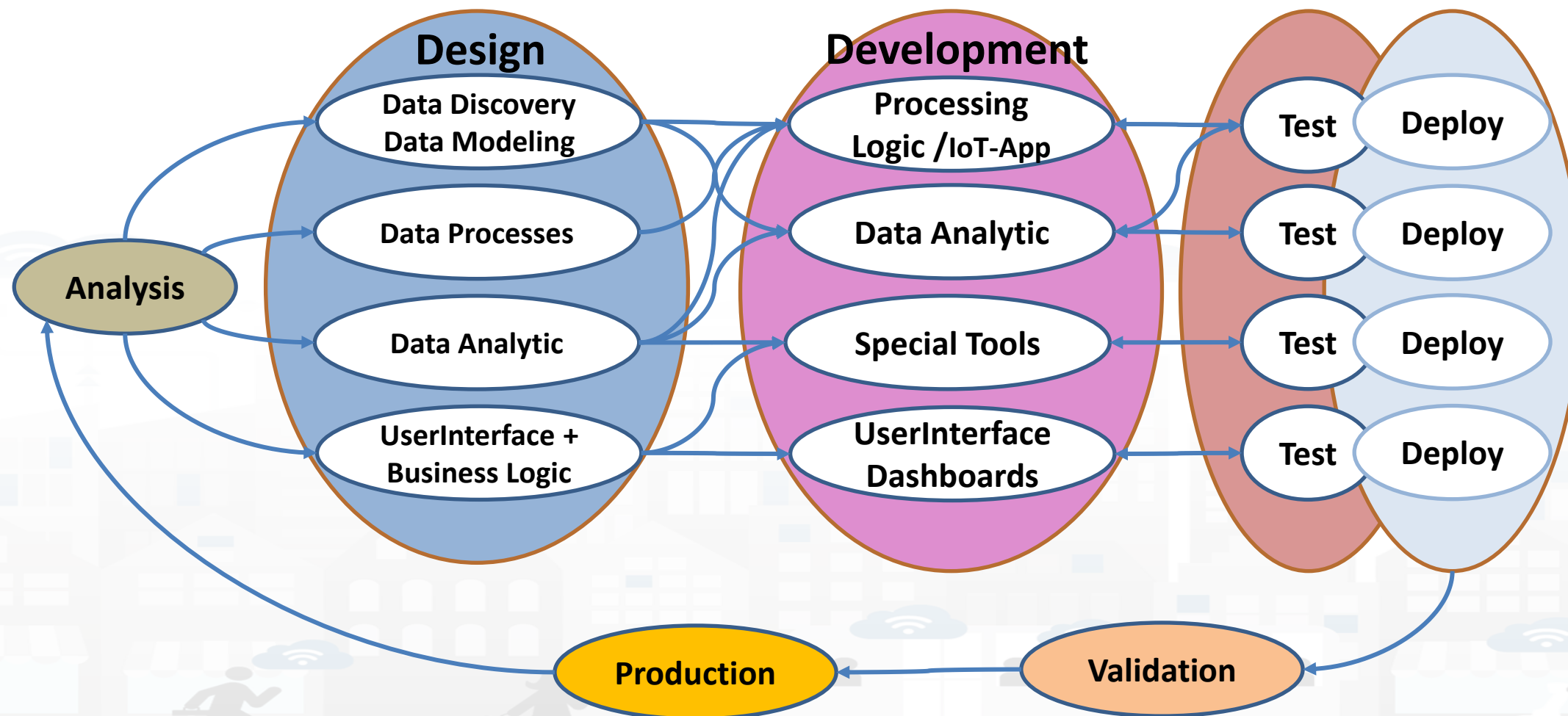

# Snap4City Tools

vs

# Development Life Cycle

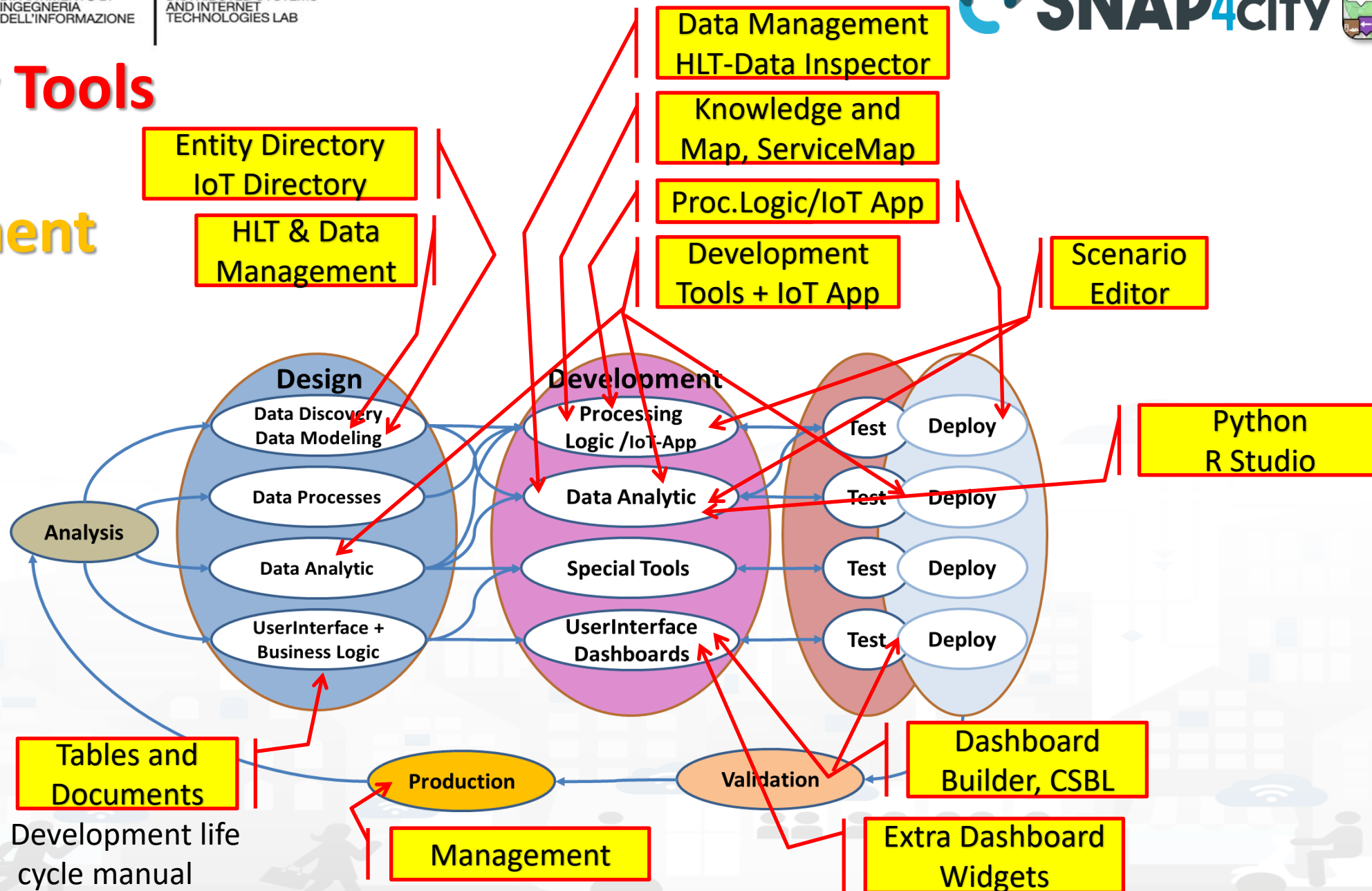

# Test & Deploy

- The activities of Test and Deploy are performed into the corresponding tools
  - **Processing Logic / IoT App Editor Node-RED** provides a button for Deploy and a Debug console for testing
  - **Data Analytics** are
    - tested on development user interface on RStudio and Python
    - Tested on Deploy when they are executed as container from IoT Apps
  - **Dashboards** are tested directly into the Dashboard editor and preview

# Validation and Production

- Is the phase in which all components can be integrated and tested in their integration on the platform ready to be used in production.
- The **validation** should be performed verifying:
  - Functional Requirements
  - Non functional Requirements
- The **production** process is very easy in Snap4City since implies to provide access to the tools and services to final users you planned.
  - The grant can be performed on Dashboard Management and on IoT Directory, and on Data Management for the data.
- Once put in production the **Solution can be monitored** in deep on Dashboard usage, on data status, on IoT App, etc. See Part 6 of the training course.

# Develop Mobile & Web Applications Exploiting Snap4City Smart City Services

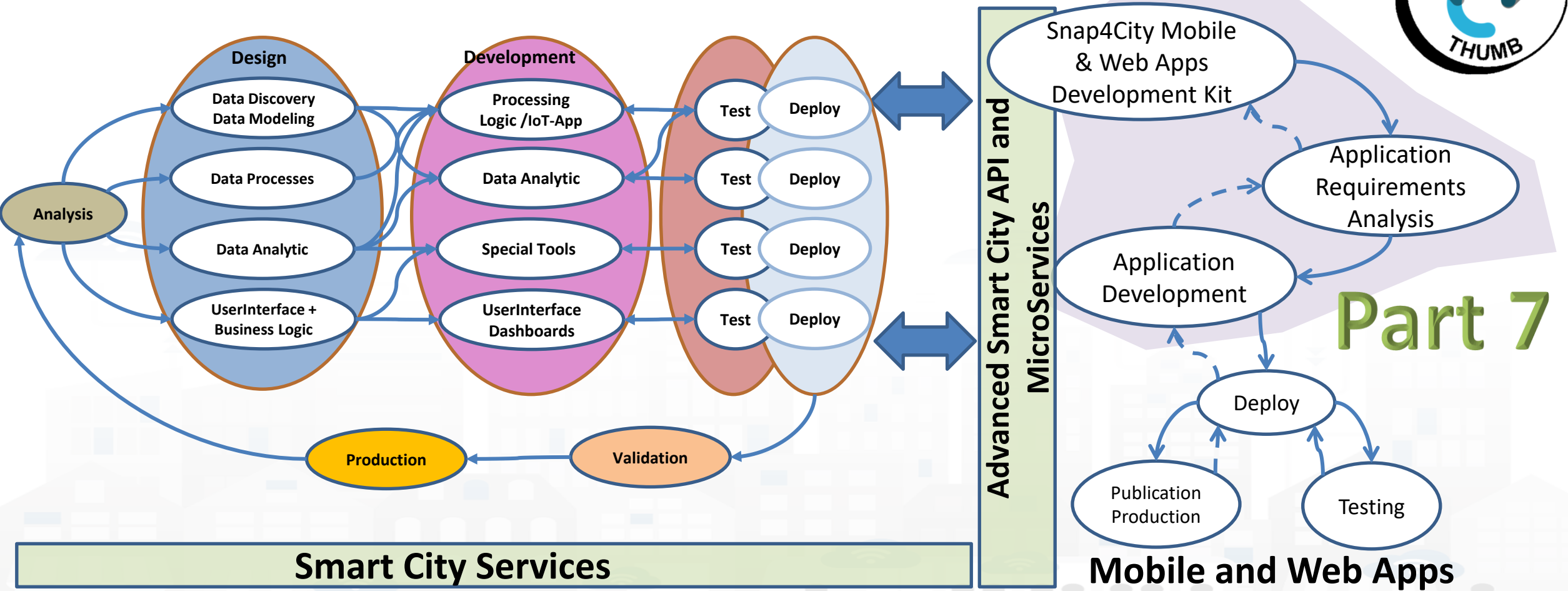

TOP

# Development Costs



# Snap4City Tools

vs

# Development Life Cycle

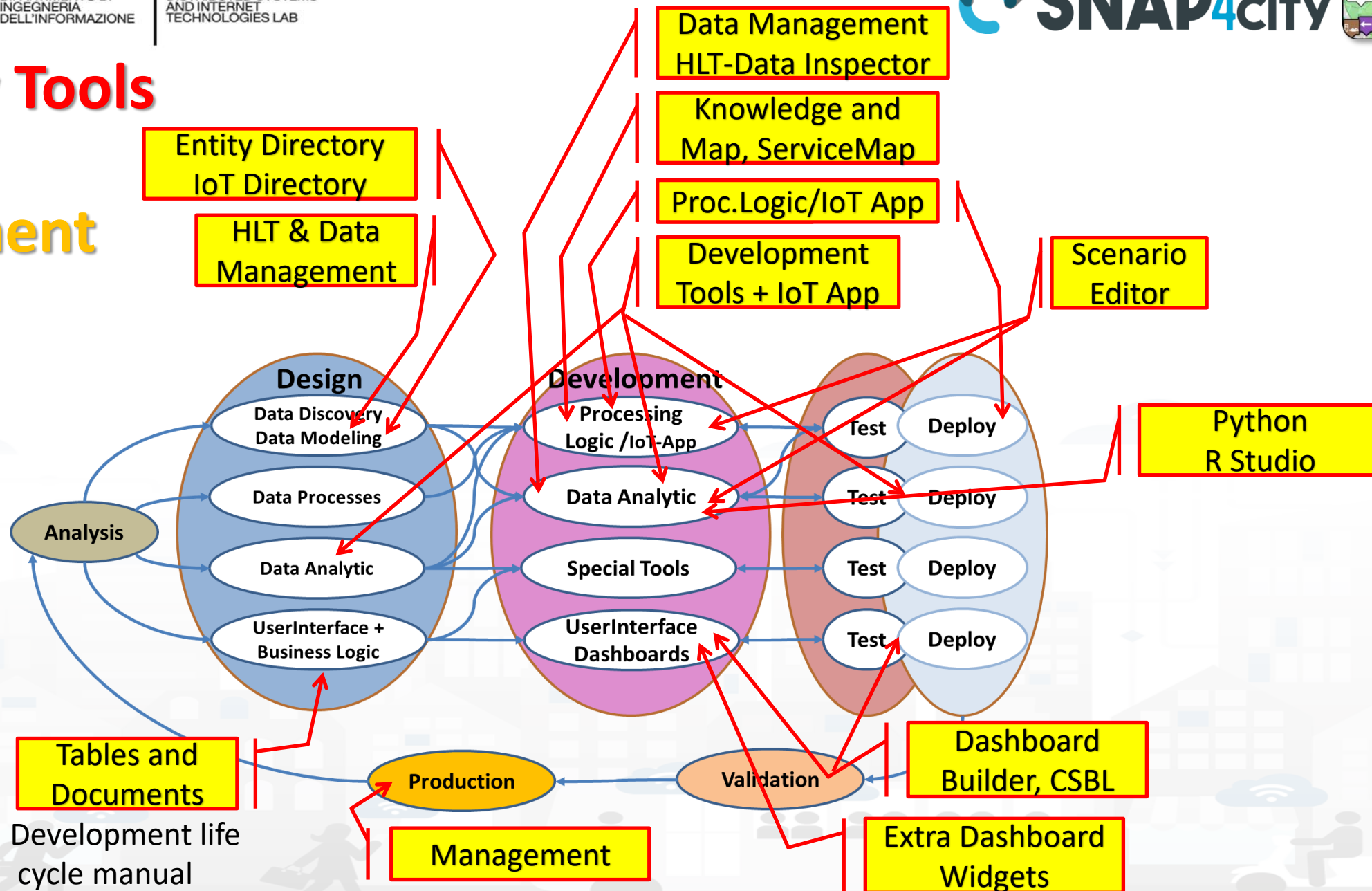



# Typical costs to setup operative conditions

- Learn Visualization Tools or Libraries: 5-15%
- Software Licenses: 5-15%
- Development Time: 20-30%
- **Infrastructure Costs: 10-20%**
- **Data Processing and Storage: 10-20%**
- Customization and Interactivity: 10-20%
- **Final Users Training and Support: 5-10%**
- **Maintenance and Updates: 10-15%**
- Design for Security/privacy: 5-10%
- Design for Scalability: 5-15%
- *In **yellow**, what is **not impacted***

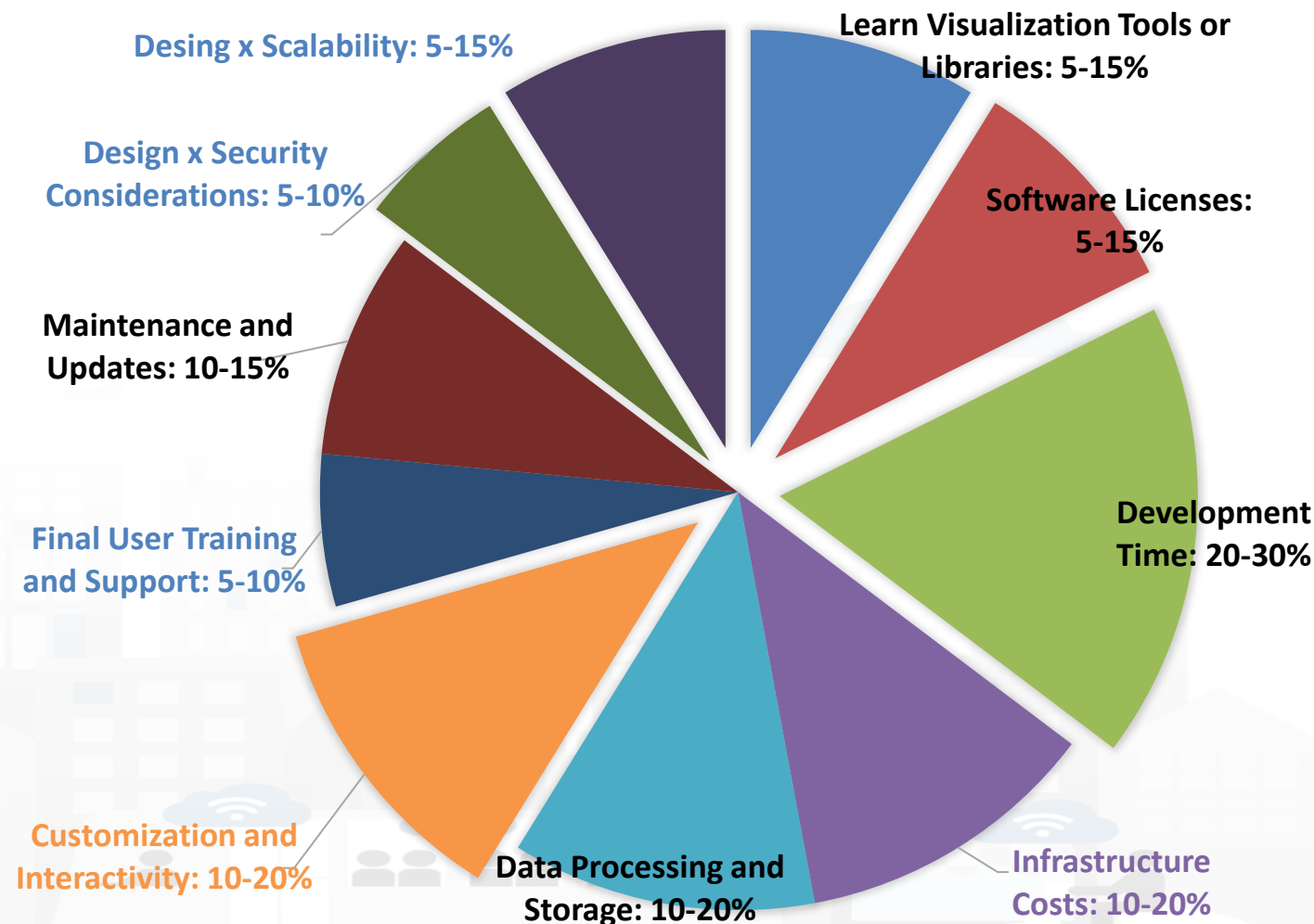

# Snap4City strongly reduces the effort/costs for

- **Learn Visualization Tools or Libraries:** 5-15% → **10%**
  - Visual tools, visual programming, training course, dev. Manuals, etc.
- **Software Licenses:** 5-15% → **0%**
  - Development environment fully open source
- **Development Time:** 20-30% → **5%**
  - Dashboard builder, synoptics, widget exchange, dashboard exchange, clone, delegations, etc.
  - Reused cloned and shared solutions, artefacts
- **Customization and Interactivity:** 10-20% → **10%**
  - Dashboards with Business Logic: CSBL, Node-red SSBL
  - Direct development of Business Intelligence without coding all details
- **Design for Security/privacy:** 5-10% → **only respect the guidelines**
  - Snap4City is end-to-end secure and GDPR compliant, all is already in place
- **Design for Scalability:** 5-15% → **only respect the guidelines**
  - Snap4City is scalable from Back-End to Front-End, all is already in place
- **Reduction of: 45% for development effort of smart city solutions**

# Model/Technique Development/testing

- **Identification of Process goals and Planning (problem definition)**
  - Which goals
  - How to compute, which language
  - Which environment, which libraries
- **Data Discovery and Ingestion (from the general life cycle)**
  - Data Collection, Data Preprocessing if needed
- **Data Analysis: feature engineering, feature selection**
  - Data ethics assessment
- **Data review and preparation for the model, splitting, encoding**
- **Model Identification and building: ML, AI, etc....**
  - Model Training
  - Tuning hyperparameters when possible
- **Model Assessment and Selection (Evaluation)**
  - Validation in testing
  - Assessment on a set of metrics depending on the goals: global relevant and feature assessment
  - Assessing computational costs
  - Impact Assessment, Ethic Assessment and incidental findings
  - Global and Local Explanation via Explainable AI techniques
- **Model Deploy and Final Validation**
  - Optimisation of computation cost for features, if needed reiterate
  - Solution on Production (security, scalability, etc.)
- **Monitoring and Maintenance on production**
- **Documentation, incremental documentation**

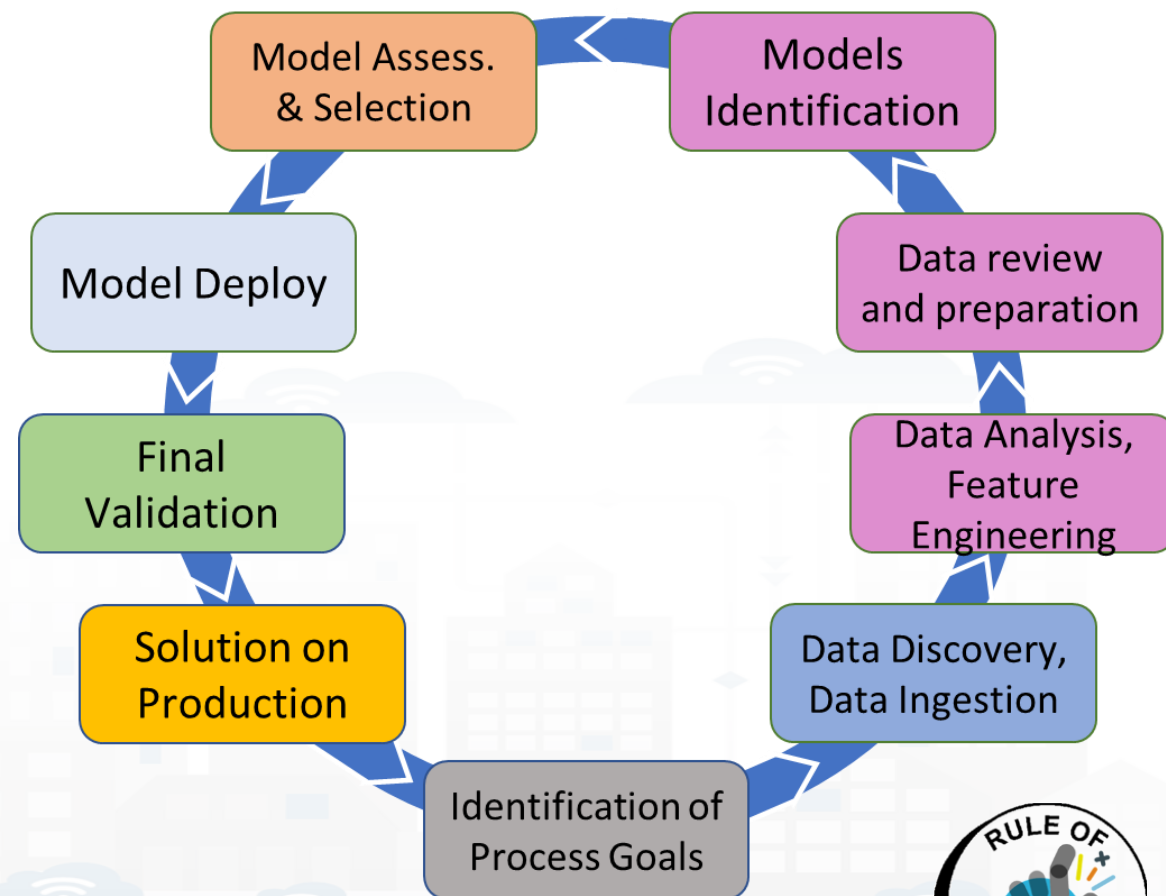

# Typical Effort of Phases without Snap4City

- Please note the *effort for Data Preprocessing and Data Collection*
  - 25-35%
- Please note that the pie has not taken into account the effort for creating
  - an actual applications or
  - simple web results rendering on dashboard

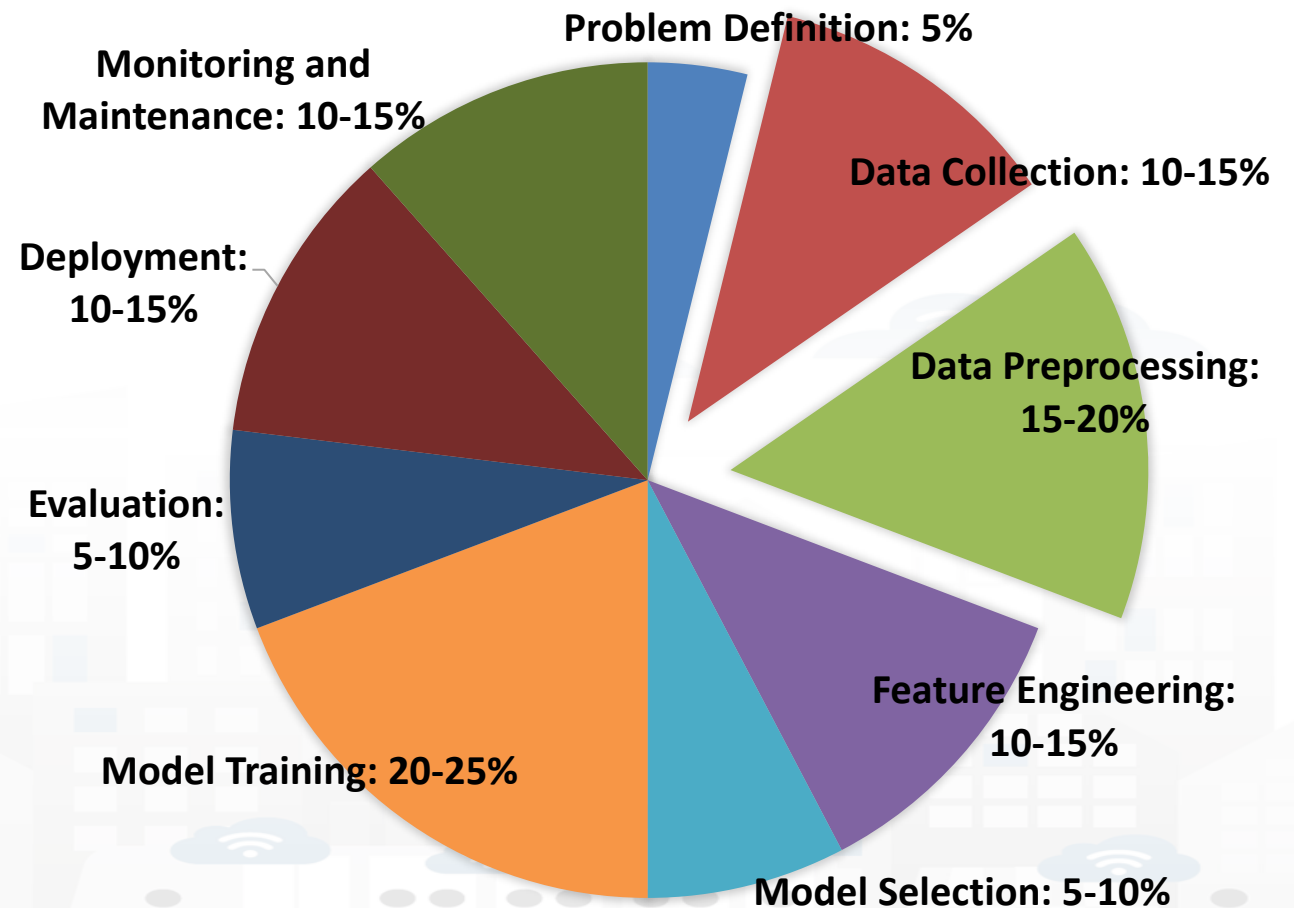

# Snap4City on *Data Collection and PreProcess*

- **Effort reduction from 25-35% to 10-15%, >55% reduction of effort for**
  - **Data Collection** via
    - Direct collection access with Brokers, harvesting of external brokers and data models
    - Usage of library of data models, more than 1700 models: saving analysis
      - Custom data models, massive automated construction of entities
    - Automated enrichment of Km4City Ontology and knowledge base: saving time analysis
    - IoT App / Node-red development of data collection processes: fast development
  - **Data PreProcess** via
    - Node-red visual programming (node.js) for preprocessing, transcoding, thousands of microservices and libraries, reuse of blocks and data flows, etc.
    - Semantic recovering of data relationships via semantic graph DB with Km4City models
    - Eventually usage of Python or R-studio or others when needed
  - *Reuse and share of Node-RED solutions, large number of cases*

TOP



# Development

<https://www.snap4city.org/download/video/Snap4Tech-Development-Life-Cycle.pdf>



## Development Life-Cycle

<https://www.snap4city.org/download/video/Snap4Tech-Development-Life-Cycle-v1-1.pdf>

### From Snap4City:

- We suggest you to read the **TECHNICAL OVERVIEW**:
  - <https://www.snap4city.org/download/video/Snap4City-PlatformOverview.pdf>
- <https://www.snap4city.org>
- <https://www.snap4solutions.org>
- <https://www.snap4industry.org>
- <https://twitter.com/snap4city>
- <https://www.facebook.com/snap4city>
- <https://www.youtube.com/channel/UC3tAO09EbNba8f2-u4vandq>

**Coordinator:** Paolo Nesi, [Paolo.nesi@unifi.it](mailto:Paolo.nesi@unifi.it)

DISIT Lab, <https://www.disit.org>  
DINFO dept of University of Florence,  
Via S. Marta 3, 50139, Firenze, Italy  
Phone: +39-335-5668674

# Development Life Cycle Smart Solutions

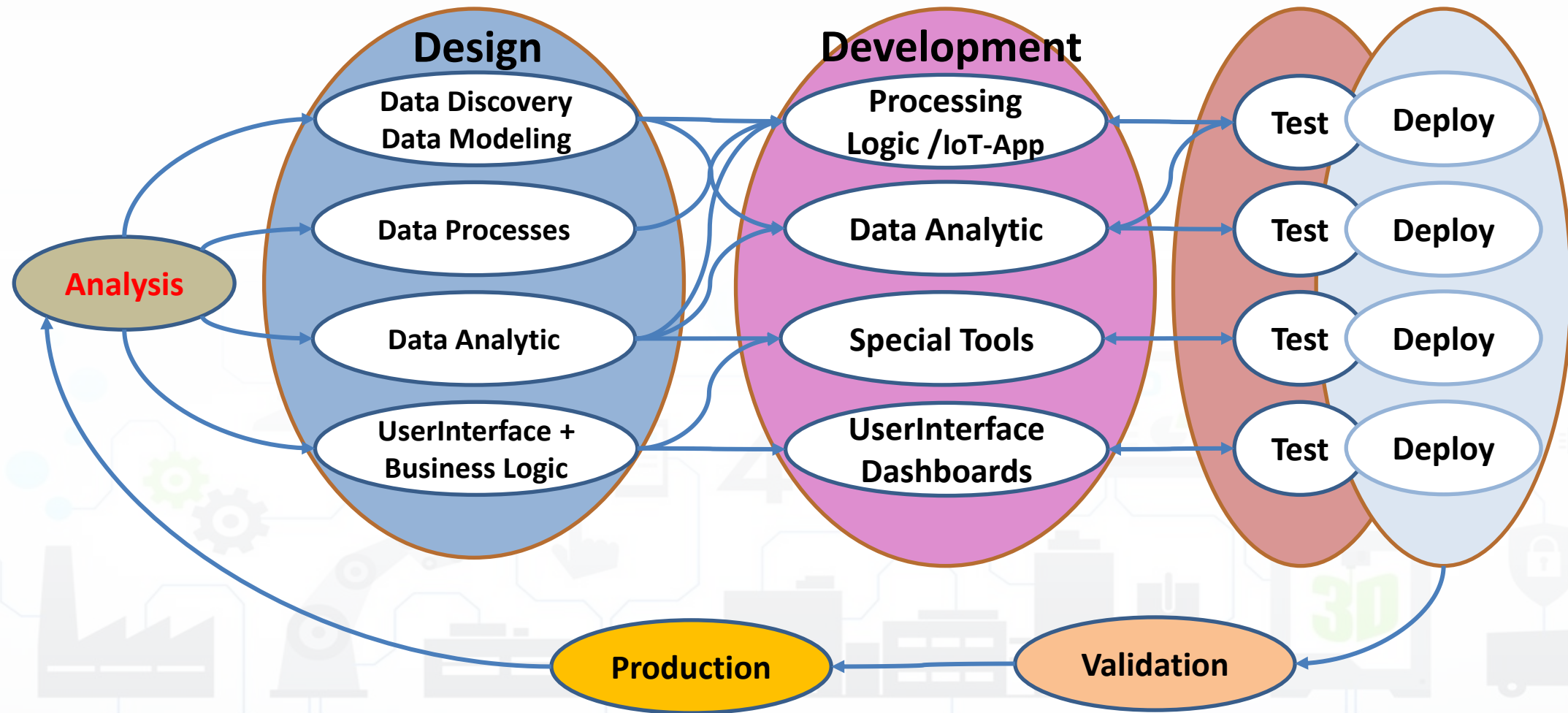



- **Performing workshops:** Innovation Matrix by domain
- **Entity Identification:** which is the **Dictionary**
  - **Actors and their profiles (as Entity Models, IoT Device Model):** User, Operator, final user, ict expert, decision maker, doctors, driver, etc.
  - **entities and their digital counterpart (as Entity Models, IoT Device Model)** for: Vehicle, Analysis, Server, Client, Mobile App, parking area, etc.
  - **Entity Instances / IoT Devices which are instances of the models** as: City user XX, Control Room Operator, Doctor Rossi, Cop 3726, Car FI796HG, IoT Device XY, Trip 34, Patient Health Record for Robert, etc.
  - **Modules or Tools** of Third party or legacy tools: they are applications, servers, IoT Edge subsystems, well known services for data providing, gateway, brokers, etc., which should interact some how with your solutions. They can be on cloud or on some premise, they can provide you some External API, of some kind: WebServer, Rest Call, FTP, Web Socket, MQTT, etc.
    - **External API:** to interoperate with any other application and service / servers.
    - **External Services / Web Pages:** to host into the user interface and Dashboards elements coming from third party applications.
    - **Tools:** which can be actual software or hardware tools, and also data analytics, algorithms, procedures.

# Snap4City Innovation Matrix and Process

## Part 6

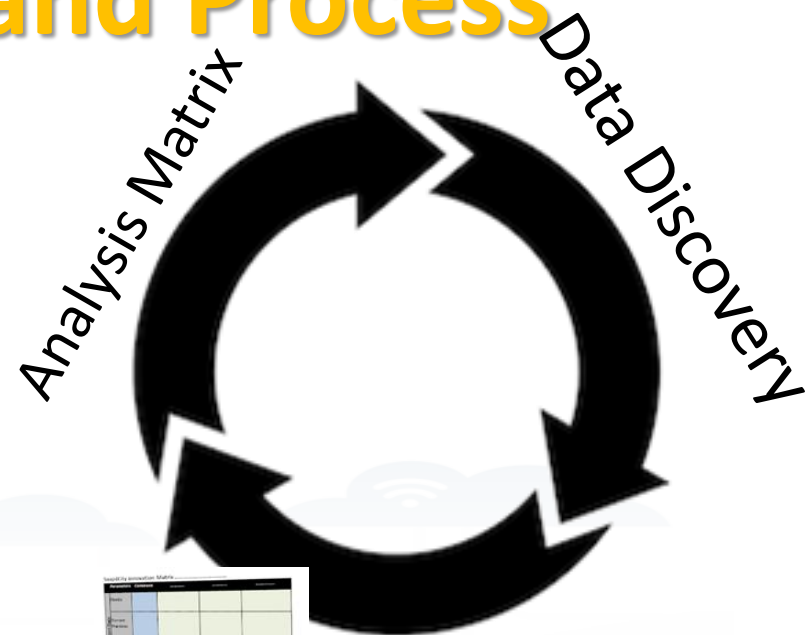

Design Scenarios

Snap4City Innovation Matrix

	Parameters	Commons	Operators	360°	Visitors
Current State	Needs	[Sticky notes]	[Sticky notes]	[Sticky notes]	[Sticky notes]
	Current Practices	[Sticky notes]	[Sticky notes]	[Sticky notes]	[Sticky notes]
	Value proposition (Current)	[Sticky notes]	[Sticky notes]	[Sticky notes]	[Sticky notes]
Future State	Value proposition (Future)	[Sticky notes]	[Sticky notes]	[Sticky notes]	[Sticky notes]
	Solution	[Sticky notes]	[Sticky notes]	[Sticky notes]	[Sticky notes]
	Value Capture	[Sticky notes]	[Sticky notes]	[Sticky notes]	[Sticky notes]
	Key Partners	[Sticky notes]	[Sticky notes]	[Sticky notes]	[Sticky notes]
	Barriers	[Sticky notes]	[Sticky notes]	[Sticky notes]	[Sticky notes]

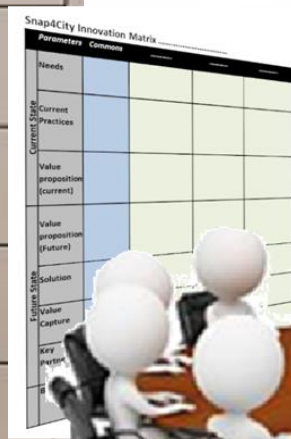

# The Dictionary of Entities

Dictionary of Entities					
Term	DataModel or Module	Kind	Responsible	Status	Spec where
Driver Healthiness	DriverHealthiness	Entity Model	Dr. Rick Ross	To be done	To be defined
User profile A	DriverA	Entity Model			
Vehicle Event	VehicleEvent	Entity Model			
Remote Console	MyOperation	Application	J.T. Kirk	To be done	lost
		IoT App			
		Dashboards			

Columns in green are expected to be filled in the design phase

- **For example:** *Let us now to suppose that we have to develop a solution for monitoring Vehicles and Drivers. Each Vehicle has a profile description and can be driven by a number of Drivers over time. **Each Vehicle** can experience some maintenance and performs trips in the city area. A trip has an official start/end and over time is described by its velocity, acceleration, brakes, charging level, or thank level, etc. **Each Driver** has a profile and can use a number of Vehicles to perform trips. During the trip also the Driver is monitored for its healthiness, attention, etc., and before, during and after the driving, periodically or sporadically may experience some Analysis to certify its capability to drive in that moment and for the next days. The Driver may experience some warning cases for healthiness, some tickets from policeman, some warning for high-speed velocity or generically bad driving, some problems from the vehicle's status, etc.*

**legenda**

- Entity Instance
- Entity Model
- Entity Messages with dateObserved

**Data Model of the Driver**

- Name: string
- Surname: string
- Age: number
- Weight: number
- Phone: string
- Email: string
- DriverAnalysisID: ServiceURI
- .....

Register to instantiate

**Driver: user45**

- Name: David
- Surname: Smith
- Age: 45
- Weight: 78 Kg
- Phone: +49345096103
- Email: [david89@gmail.com](mailto:david89@gmail.com)
- **NikName: Carl**
- DriverAnalysis: <http://.../user45driveranalysis>
- .....

Write SURIs to create cross references

**DriverAnalysis: user45driveranalysis**

- DriverID: <http://.../user45>
- dateObserved: 12-03-2022T12:00:00
- Status: "none"
- Location: null
- Doctor: null
- Tools: null
- .....

Register to instantiate

**DriverAnalysis: user45driveranalysis**

- DriverID: <http://.../user45>
- dateObserved: 25-04-2022T12:00:00
- Status: "bad"
- Location: truck
- Doctor: null
- Tools: Eyetrack
- .....

New update on user45driveranalysis by sending a message

**DriverAnalysis: user45driveranalysis**

- DriverID: <http://.../user45>
- dateObserved: 22-03-2022T12:00:00
- Status: "good"
- Location: room45
- Doctor: <https://.....>
- Tools: null
- .....

New update on user45driveranalysis by sending a message

**legenda**

- Entity Instance
- Entity Model
- Entity Messages with dateObserved

Register to instantiate

**Driver: user45**

- Name: David
- Surname: Smith
- Age: 45
- Weight: 78 Kg
- Phone: +49345096103
- Email: [david89@gmail.com](mailto:david89@gmail.com)
- NikName: Carl
- DriverAnalysis: <http://.../user45driveranalysis>
- .....

*Handwritten notes: "Date observed" and "time" with arrows pointing to the DriverAnalysis link and a separate box.*

**DriverAnalysis: user45driveranalysis**

- DriverID: <http://.../user45>
- dateObserved: 25-04-2022T12:00:00
- Status: "bad"
- Location: truck
- Doctor: null
- Tools: Eyetrack
- .....

**Data Model of the Driver**

- Name: string
- Surname: string
- Age: number
- Weight: number
- Phone: string
- Email: string
- DriverAnalysisID: <http://.../user45driveranalysis>
- ServiceURI
- .....

Write SURJ to create cross references

**DriverAnalysis: user45driveranalysis**

- DriverID: <http://.../user45>
- dateObserved: 12-03-2022T12:00:00
- Status: "none"
- Location: null
- Doctor: null
- Tools: null
- .....

New update on user45driveranalysis by sending a message

**DriverAnalysis: user45driveranalysis**

- DriverID: <http://.../user45>
- dateObserved: 22-03-2022T12:00:00
- Status: "good"
- Location: room45
- Doctor: <https://.....>
- Tools: null
- .....

New update on user45driveranalysis by sending a message

Register to instantiate

# API, External Services

External API							
API name	API url and shape	Kind	parameter	Credentials approach	status	Description, Swagger link, Postman, ...	
	GIS...						
	CKAN...						

Columns in green are expected to be filled in the design phase

External Services				
URL Web pages	parameter	Description	Nature	Subnature

These info can be loaded on Snap4City platform to show them on dashboards easily

# Analysis 2/2

- **Scenarios** describing the application/task, textual definition, with some standard table as UML. The scenarios have to refer to identified entities.
  - <https://www.uml-diagrams.org/activity-diagrams-examples.html>
- **Use Cases** describing the different cases into the single applications, by using UML formalization, there are specific Use Cases for each Scenario. Please focus on the most relevant, those that are adding value to your solutions. The others can be given for granted in a first phase.
- **Requirements** by using standard tables, using identified **Dictionary of Entities**, prioritizing them, setting mandatory/preferred/optional, functional and non-functional, first/second/third release, etc.
- **Sequence Diagrams:** for some of the critical aspects- For example for describing the user interaction, and/or the interaction among major entities, putting in evidence which is the Entity starting the dialogue with respect to the other **Entities** involved (e.g., a client requesting data to the server, a device sending data to the broker). UML sequence diagrams are a suitable formalization for the purpose.
  - [https://en.wikipedia.org/wiki/Sequence\\_diagram](https://en.wikipedia.org/wiki/Sequence_diagram)



# Example: Activity Diagram

- **Continuous Lines** can denote event driven, sync communications... for example by sending data on IoT Broker
- **Dashed lines** can denote Pull data collected. Via Async. Communication from Platform to Mobile Devices, via SCAPI
- **Dotted line** can be even driven internal mechanism, internal call of API or other event drv.
- **Coloured Dots** are the different devices datastorage

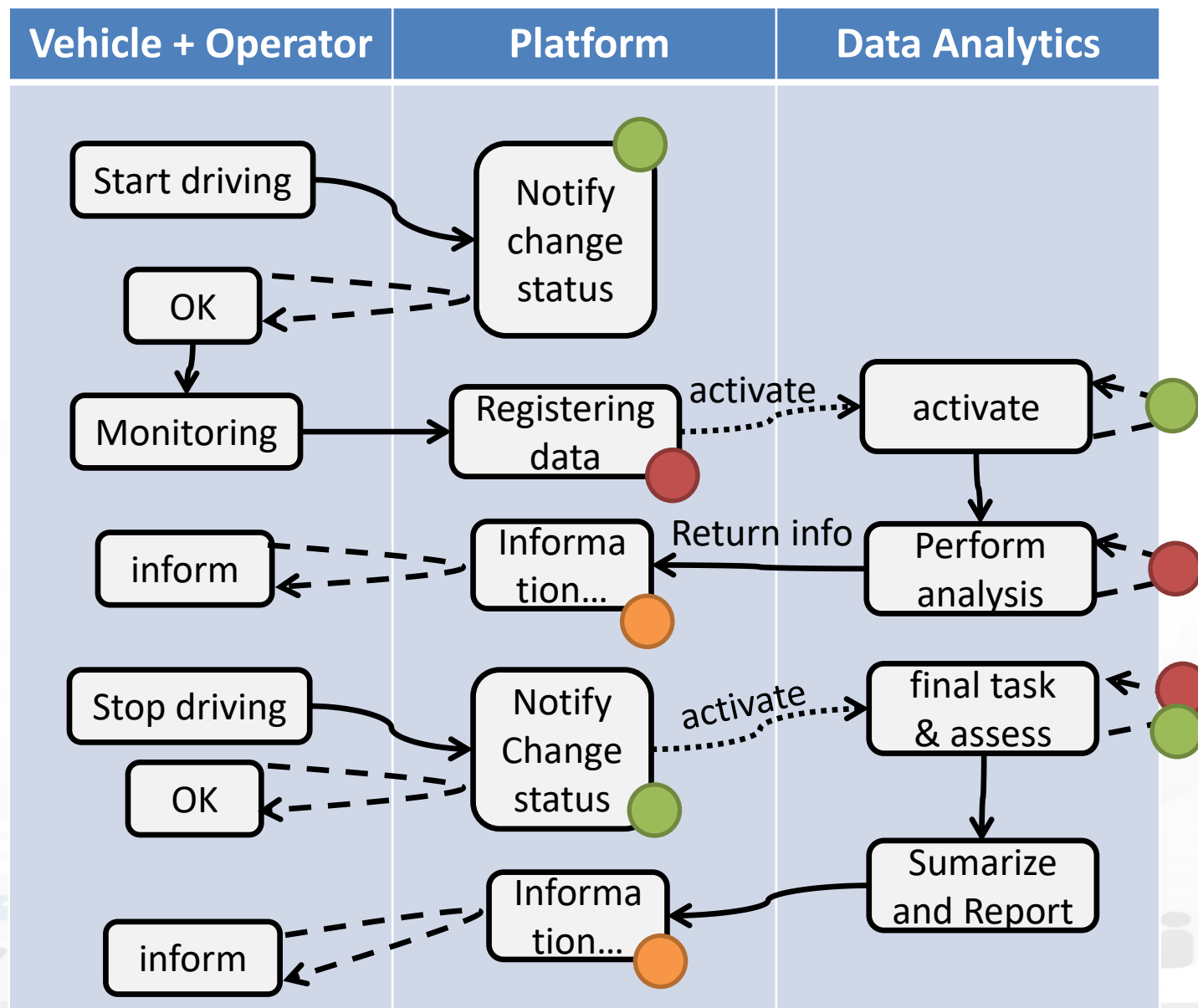

- Every time a data is entered into the Storage an event occurs into the broker
- The server «Inform» can be subscribed from an IoT App to receive in push these changes **(red dashed line)**

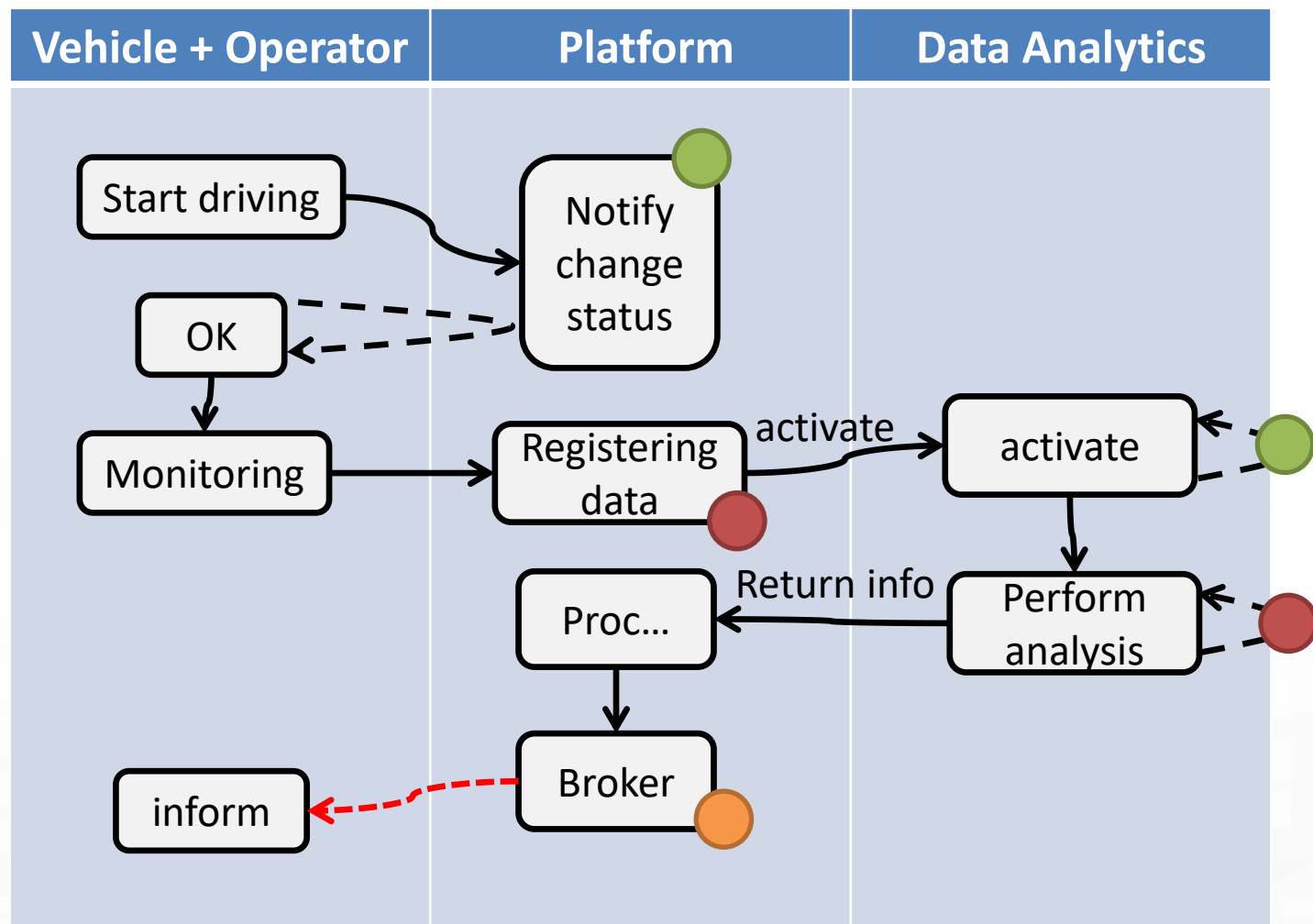

# A variant

- Every time a data is entered into the Storage an event occurs into the broker
- The server «Inform» can be subscribed from an IoT App to receive in push these changes **(red dashed line)**

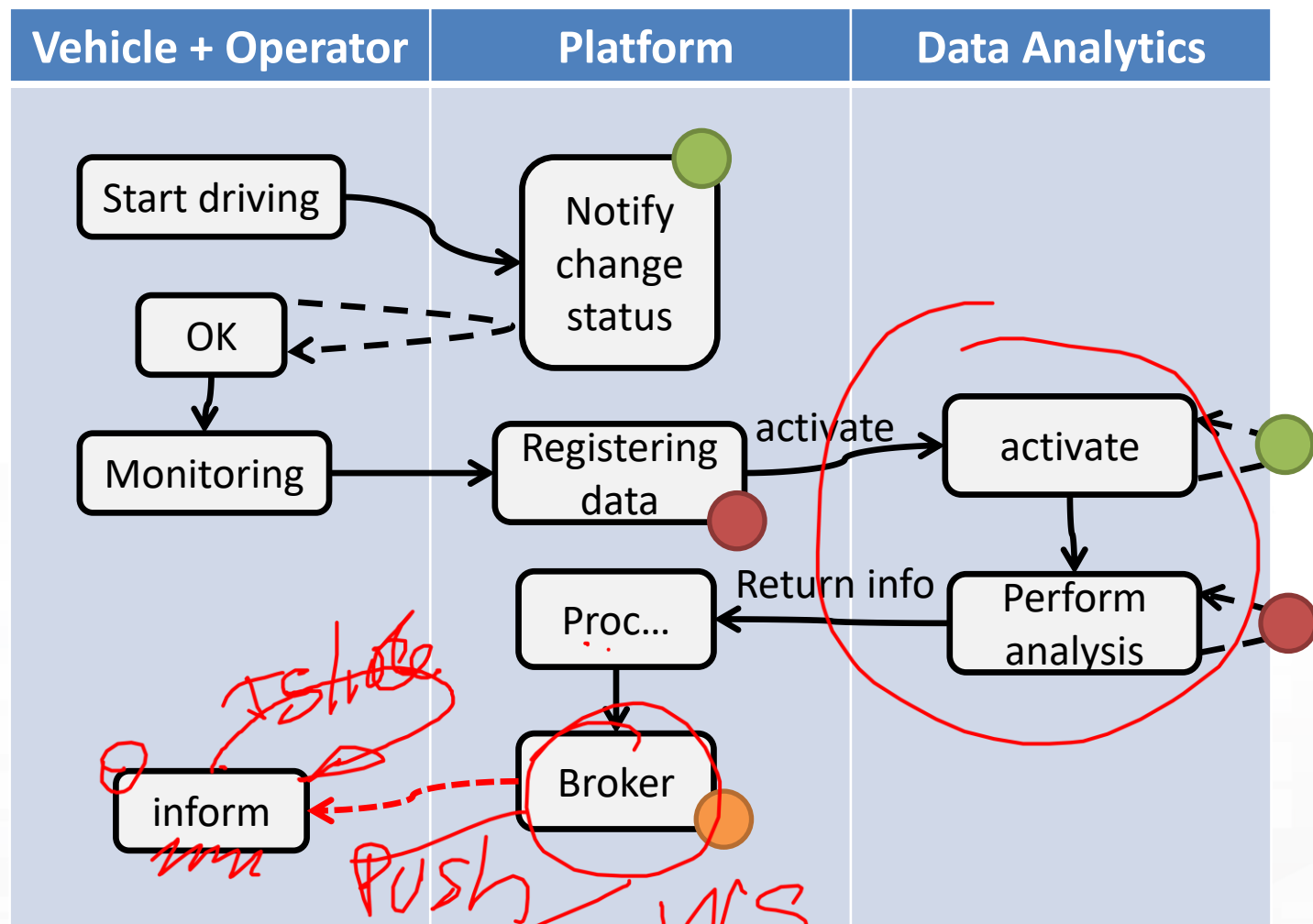

# The above figure

- The driver on its Mobile App, he/she marks the start of the driving section, and the App notifies the change of status to the platform via some broker, once performed all the needed verifications (taking some minutes, may be).
- The effective change and authorization to start is made accessible by the platform to the mobile app which is requesting the status in pull (dashed line).
- Then the mobile app starts to monitor the drive status continuously, and send new data (e.g., the level of attention, the road taken, etc.) to the platform via some broker every minute.
- The arrival of new data may activate some data analytics to perform some analysis of the collected data (red dots) and producing results on the platform data. In the case in which the process detected critical conditions for the driver, the assessment procedure on platform may decide to send an event/message (dashed red, in push from platform to clients) to the operator and driver via a Broker to warning the driving of the lack of attention or for some wrong path.
- The event in push from platform to client could be a viable approach on some platforms and may have some limitation on Mobile App in which the interaction paradigm can be changed in a periodic REST call from the Mobile to the Platform.

# Legenda on REST Call 1/2

- the **black continuous line** (push) will be used to send some data on the platform broker with a REST call which has to be Authenticated and Authorized according to the OpenId Connect as explained later, and would be in the form of:
  - <https://<platformdomain>:8443/orionbrokerfilter/v1/updateContext>
  - Or in the form for non TSL protected interaction:
    - <http://iot-app.snap4city.org:80/orion-broker/v1/updateContext?elementid=ELEMENTID&k1=K1&k2=K2>
- the **black dashed line** (pull) will be used to request some data from the platform by using a REST call to smart city API (Authenticated and Authorized according to the OpenId Connect as explained later), in the forms:
  - via regular Smart city API by category, etc.
    - [http://svealand.snap4city.org/ServiceMap/api/v1/?selection=59.581458578537955;16.71183586120606;59.62875017053684;16.875171661376957&categories=Street\\_light&maxResults=100&format=json](http://svealand.snap4city.org/ServiceMap/api/v1/?selection=59.581458578537955;16.71183586120606;59.62875017053684;16.875171661376957&categories=Street_light&maxResults=100&format=json)
  - Via Super
    - <https://www.disit.org/superservicemap/api/v1/?.....>
  - Via Super by values
    - <https://www.snap4city.org/superservicemap/api/v1/iot-search/?selection=43.77;11.2&maxDists=700.2&model=CarPark>
  - <https://www.snap4city.org/superservicemap/api/v1/iot-search/?selection=42.014990;10.217347;43.7768;11.2515&model=metrotrafficsensor&valueFilters=vehicleFlow>0.5;vehicleFlow<300>

# Legenda on REST Call 2/2

- the **red dashed line** (push) will be used to send some data from the platform (from an Orion broker) to some stable IP client or other machine for machine-to-machine communication
  - As a first step the client has to subscribe to some entity on the Orion Broker passing its IP where the broker will have to send the data in push
    - The POST will be in the form of [/v1/subscribeContext](#) passing as parameters: elementid (the device ID, and K1, K2) or TSL approach
    - ```
curl -X POST "https://broker1.snap4city.org:8080/v1/subscribeContext?elementid=myspersonaldatatester-device&k1=4e0924a8-fdd6-49cf-8d4a-f49cb5710d8b&k2=240567da-64a4-43b3-8ac9-1265178f3cbe" -H "accept: application/json" -H "Content-Type: application/json" -d '{"entities":{"type":"Ambiental","isPattern":false,"id":"myspersonaldatatester-device"},"attributes":{"temperature"},"reference":"http://prova/","duration":"P1M","notifyConditions":{"type":"ONCHANGE","condValues":{"temperature"},"throttling":"PT10S"}' -d
```
  - Then the broker will send the messages to the subscribed client
  - it could be possible to have this kind of push also by using Kafka and/or WebSocket, but this is possible with simple and direct exposed API to all Snap4City platforms.
- **The external APIs of Snap4City are documented in Swagger**
  - <https://www.km4city.org/swagger/external/index.html>

## Requirements

| ID | Main Entity / Area | Description                                                                                     | Relevance / Priority | Main Tool-Module / Entity involved               | Status                    | Source Code                       |
|----|--------------------|-------------------------------------------------------------------------------------------------|----------------------|--------------------------------------------------|---------------------------|-----------------------------------|
| D1 | Operator           | The Operator has to be authorized to register Drivers                                           | mandatory            | OperatorTool                                     | Not developed             | JavaScript by xxxx on GitLab .... |
| D2 | Driver             | The Drive can verify its registration by putting Password to access to its data on the solution | optional             | Web and/or Mobile App accessible for the Drivers | accessible as open source | Yes In Java with AGPL licence     |
|    | OperatorTool       | Has to provide the list of pending assessment to be done                                        |                      |                                                  |                           |                                   |

Columns in green are expected to be filled in the design phase

# Non Functional Requirements



Somehow related each other

- Protection, privacy, PENTest, GDPR compliance, ...
- Scalability, performance, efficiency, cloud/edge/container compliance
- Resilience, robustness
- Modularity, flexibility, reusability, maintainability, ..
- Portability, Openness, opensource
- Interoperability, standards compliance
- Responsive, usability, ..
- Etc.

*All largely covered by Snap4City platform*



## Be carefull



- **Despite** the Snap4City platform provides a full range of Non-Functional Requirements
  - You can with your analysis and design produce poor solutions
- **For example, it is not a good approach to:**
  - Collect user profiles and putting them public
  - Collect data every 10 second of phenomena which change only once a day
  - Couple your web/mobile applications with server-side processes by using synchronous communication in a context which is not synchronous and neither real time

- ***As a general remark:***

*Do not worry if at the first sprint of the above steps you forgotten to fill some details. It is quite sure that, you have also provided some details that would have to be revised/changed at the next iteration.*

*The suggestion is **start developing from the core parts**, which are the production of Entity Instances from the Entity Models, the ingestion of Entity Messages for the Entity Instances, etc., and detailing the most relevant and innovative Use Cases with respect to the state of the art.*

*They would leverage the smart solutions to a new level, at each sprint.*

TOP

# Design: Data, Data Models, Data Relationships



# Development Life Cycle Smart Solutions

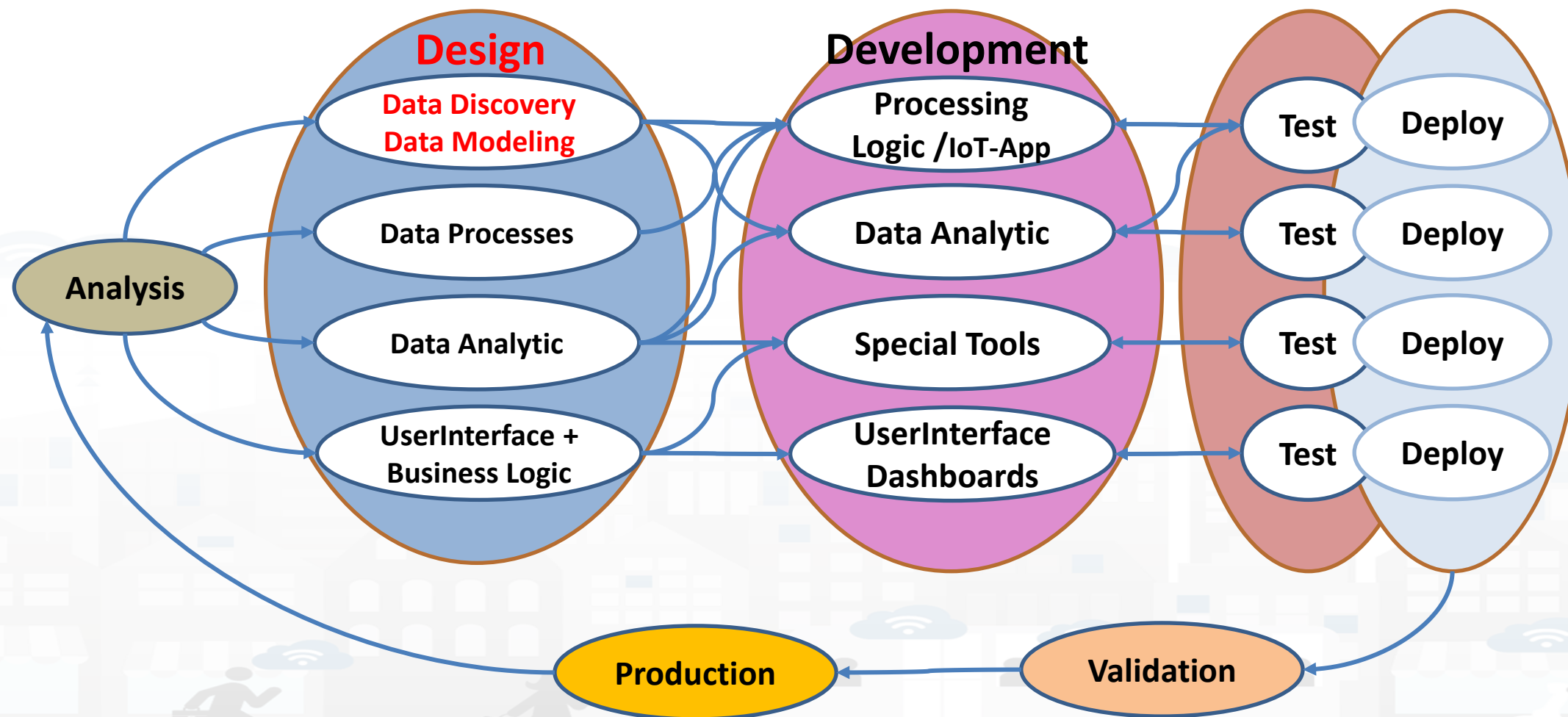

# Main Activities of Design

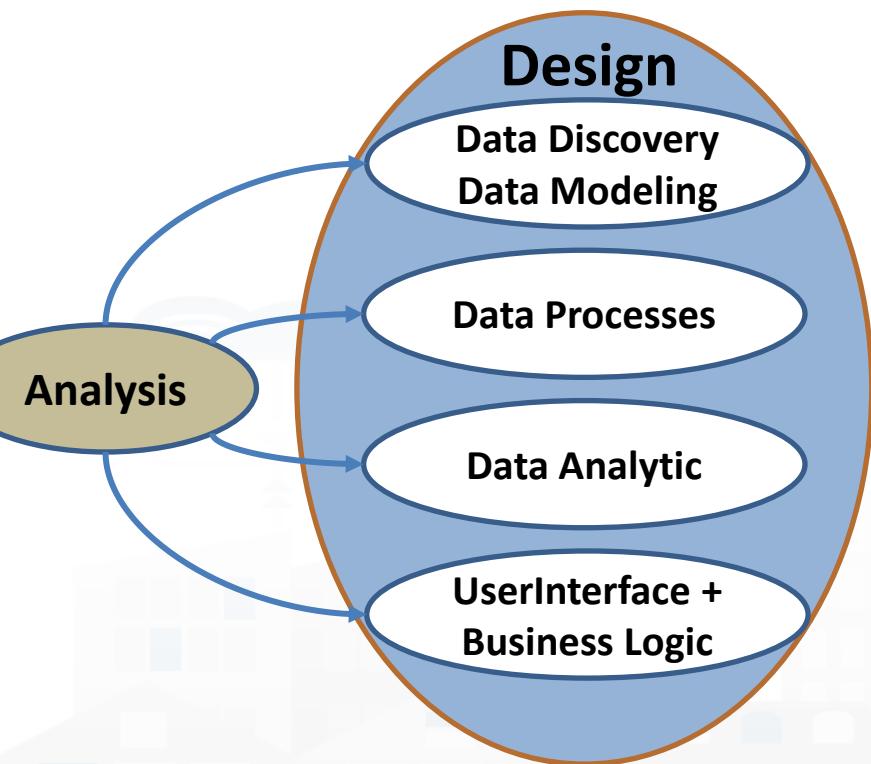

- **Data Discovery:** Ingestion, gathering, interoperability, discovery, modeling, aggregation, mapping → digital twin modeling
- **Data Processing:** transformation, interoperability; computing Indexes, KPIs and benchmarks, ...
- **Data Analytic:** statistic, predictions, classification, anomaly detection, simulations, optimization, routing, ML, AI, XAI, HPC, ...
- **User Interface:** dashboards, web pages, business intelligence, visual analytics, what-if analysis, business logic, mobile applications.

# Snap4City Tools

vs

# Development Life Cycle

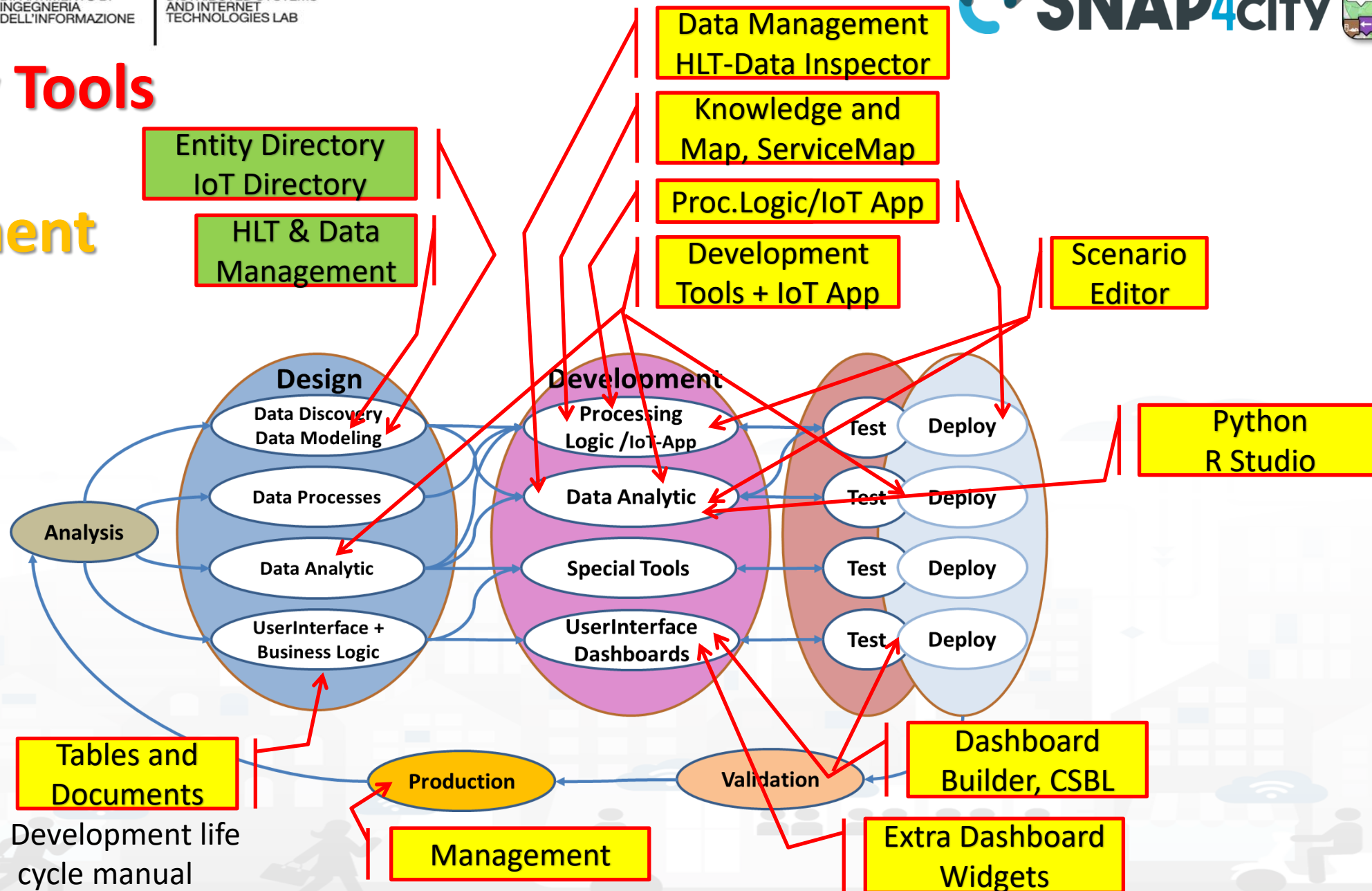

# *Design: Data Discovery*



# Data Discovery



- Performed by analyzing data from:
  - I. identified scenarios from the **Snap4City Innovation Matrix**
  - II. main organizations, third parties (via interviews)
  - III. other stakeholders (via interview and web pages)
  - IV. regional, national and international sources:
    - I. open data portals, CKAN network, weather sources,
    - II. IOT networks, etc. via web pages and sites
  - V. Mobile Applications (via Snap4City API)
  - VI. Snap4City portal <https://www.snap4city.org>
  - VII. Data market.....
  - VIII. etc.
- Exploiting Snap4City experience, data and tools
- By following the Snap4City guidelines on Data Search on web and world reported in the training course and on Snap4City.org portal.



# Data Collection per Domain/Scenario

| Description              | domain    | S/CO/RT     | I/O    | Type          | Status        | Referen<br>t    | Provid<br>er          | endpoi<br>nt | Authent<br>ication | HL<br>protocol | protoc<br>ol | HLT                 | Format  | Size               | Volum<br>e    | Rate                                   | GPS<br>ed      | foto | License /<br>Condition of<br>use |
|--------------------------|-----------|-------------|--------|---------------|---------------|-----------------|-----------------------|--------------|--------------------|----------------|--------------|---------------------|---------|--------------------|---------------|----------------------------------------|----------------|------|----------------------------------|
| Graph road               | Energy    | Static      | In     | Struct        | Understood    | Name<br>Surname | Stakehol<br>der ID    | url          | Simple             | Push           | Datex        | Sensor              | XML     | 2<br>variable<br>s | 10Byte        | Every 10<br>minutes                    | Yes            | URL, | Public as CC...                  |
| Parking                  | Graph     | Real Time   | Out    | Non<br>struct | Acquired      | Email           | Staff or<br>not staff | Broker       | Certificate        | Pull           | WS           | Sens-<br>Actuator   | JSON    | 15<br>fields       | 1245<br>Kbyte | Sporadic,<br>max 1000<br>times per day | No             | IMG  | Link to file                     |
| Consumption<br>of energy | Mobility  | Combined    | In/out |               | Scheduled     | Phone           | Internal..            |              | Etc.               |                | REST         | KPI                 | GeoJSON |                    |               | Periodic                               | Kind           |      | Private ...                      |
|                          | Transport | RT stream   |        |               | Tested        | Etc..           |                       |              |                    |                | Custom       | Personal<br>Data    | KMZ     |                    |               | 2 per day                              | Insid<br>e msg |      | Restricted to ...                |
|                          | ....      | RT Messages |        |               | Operative     |                 |                       |              |                    |                | ODBC         | Ext Srv             | WFS     |                    |               |                                        | Static<br>...  |      | Sensible data                    |
|                          |           |             |        |               | Failed        |                 |                       |              |                    |                | JDBC         | IOT                 | WMS     |                    |               |                                        |                |      | GDPR aspects                     |
|                          |           |             |        |               | Not<br>needed |                 |                       |              |                    |                |              | Virtual<br>Sensor   | GTFS    |                    |               |                                        |                |      |                                  |
|                          |           |             |        |               |               |                 |                       |              |                    |                |              | GIS                 | db      |                    |               |                                        |                |      |                                  |
|                          |           |             |        |               |               |                 |                       |              |                    |                |              | Heatmap             |         |                    |               |                                        |                |      |                                  |
|                          |           |             |        |               |               |                 |                       |              |                    |                |              | Path,<br>trajectory |         |                    |               |                                        |                |      |                                  |
|                          |           |             |        |               |               |                 |                       |              |                    |                |              | Trend               |         |                    |               |                                        |                |      |                                  |
|                          |           |             |        |               |               |                 |                       |              |                    |                |              | ....                |         |                    |               |                                        |                |      |                                  |

**Examples are provided per colum.**

The resulted raws may have not sense.

The status refers to the ingestion process.



TOP

# *Design: Data Modeling*

Part 4

Part 5



# High Level Types

Snap4City (C), Sept. 2024

- POI, IOT Devices, shapes, ...
  - FIWARE Smart Data Models,
  - IoT Device Models
- GIS, maps, orthomaps, WFS/WMS, GeoTiff, calibrated heatmaps, ...
- Satellite data, ...
- traffic flow, typical trends, ...
- trajectories, events, Workflow, ...
- 3D Models, BIM, Digital Twins, ...
- OD Matrices of several kinds, ...
- Dynamic icons/pins, ...
- Synoptics, animations, ...
- KPI, personal KPI, ...
- social media data, TV Stream,
- routing, multimodal, constraints, ...
- decision scenarios, ....
- etc.

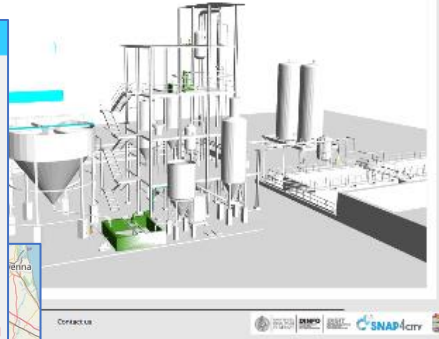
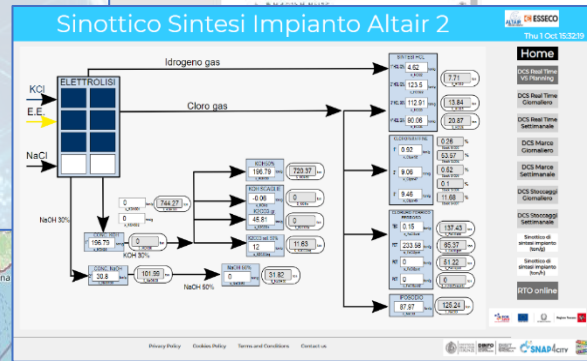
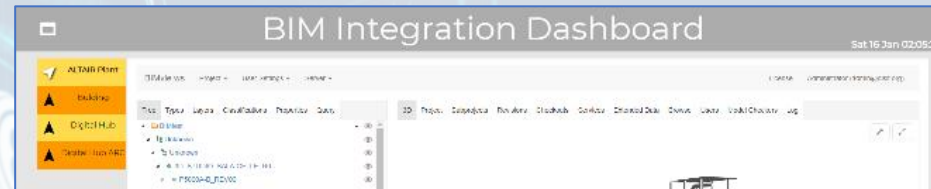

**SNAP4CITY**  
- Digital Twin Global - Fire  
demonstrator

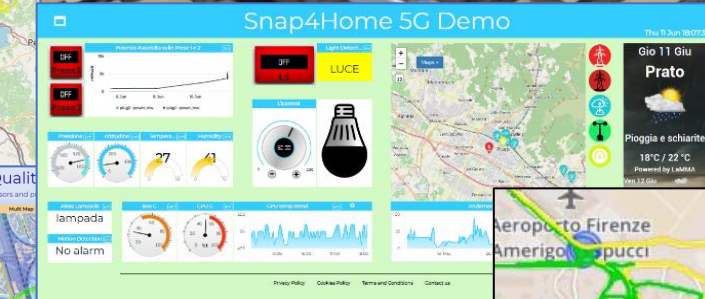
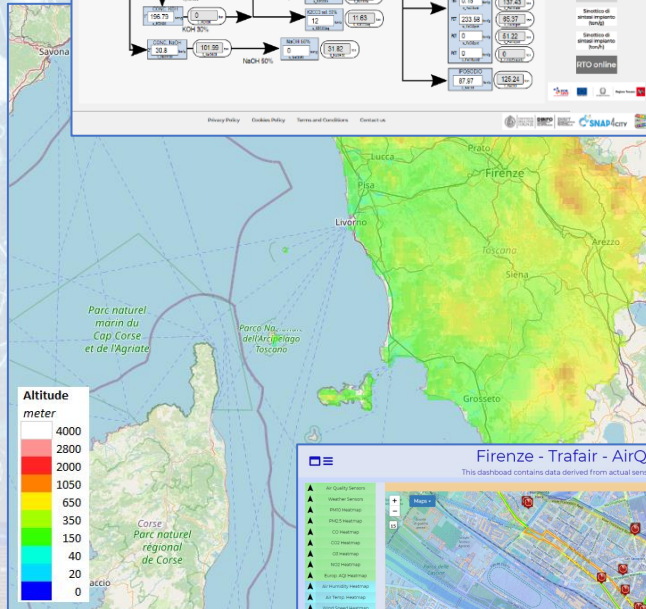

UNIVERSITÀ  
DEGLI STUDI  
FIRENZE

**DINFO**  
DIPARTIMENTO DI  
INGEGNERIA  
DELL'INFORMAZIONE

**DISIT**  
DISTRIBUTED SYSTEMS  
AND INTERNET  
TECHNOLOGIES LAB

# Standards and Interoperability (6/2023)



## Compliant with:

- **IoT:** NGSi V2/LD, LoRa, LoRaWan, MQTT, AMQP, COAP, OneM2M, TheThingsNetwork, SigFOX, Libelium, IBIMET/IBE, Enocean, Zigbee, DALI, ISEMC, Alexa, Sonoff, HUE Philips, Tplink, BACnet, TALQ, Protocol Buffer, KNX, OBD2, Proximus, ..
- **IoT model:** FIWARE Smart Data Model, Snap4City IoT Device Models
- **General:** HTTP, HTTPS, TLS, Rest Call, SNMP, TCP, UDP, SOAP, WSDL, FTP, FTPS, WebSocket, WebSocket Secure, GML, WFS, WMS, RTSP, ONVIF, AXIS TVCam, CISCO Meraki, OSM, Copernicus, The Weather Channel, Open Weather, OLAP, VMS Milestone, ....
- **Formats:** JSON, GeoJSON, XML, CSV, GeoTIFF, OWL, WKT, KML, SHP, db, XLS, XLSX, TXT, HTML, CSS, SVG, IFC, XPDL, OSM, Enfuser FMI, Lidar, gITF, GLB, DTM, GDAL, Satellite, D3 JSON, ...
- **Database:** Open Search, MySQL, Mongo, HBASE, SOLR, SPARQL, ODBC, JDBC, Elastic Search, Phoenix, PostGres, MS Azure, ..
- **Industry:** OPC/OPC-UA, OLAP, ModBUS, RS485, RS232,..
- **Mobility:** DATEX, GTFS, Transmodel, ETSI, NeTEx, ..
- **Social:** Twitter, FaceBook, Telegram, ..
- **Events:** SMS, EMAIL, CAP, RSS Feed, ..
- **OS:** Linux, Windows, Android, Raspberry Pi, Local File System, AXIS, ESP32, etc.

<https://www.snap4city.org/65>

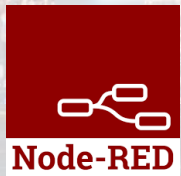

## What About Entity Instances / IoT Devices, Time Series

### Entity / IOT Device



Entity: IOT  
Device

Sends a  
message

Message (  
timestamp: 02-04-2020 at 10:30,  
Temperature: 29.34,  
Humidity: 35  
)

- A set of data coming from an Entity Instance / IoT Device with multiple sensor become a time series of values for devices.
  - For example: taking a new measure every 10 minutes (**Red Lines**)
  - Non regular rates can be valid data as well.
- Each new measure in Snap4City is conventionally time located in «**dateObserved**», which has to be **Unique**.
  - **Only one message per dateObserved is allowed**

| dateObserved     | Temp | Humidity |
|------------------|------|----------|
| 02-04-2020 10:30 | 34.5 | 23       |
| 02-04-2020 10:40 | 36.5 | 24       |
| 02-04-2020 10:50 | 36.0 | 22.5     |
|                  |      |          |

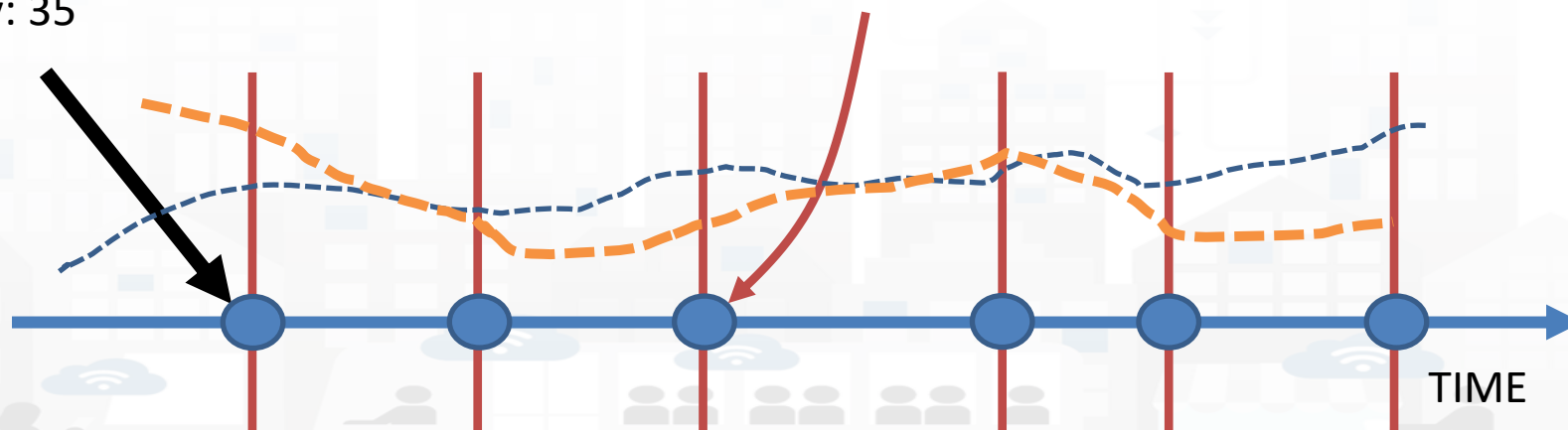

## Time Series: they are data streams

- As soon as you have registered an Entity Instance / IoT Device
  - You are ready to get Future data, may be arriving in PUSH
  - Recall and store historical data as well, but they have to be
    - recalled in PULL with some IoT App.
    - Loaded in PULL with some File or Data Table Loader

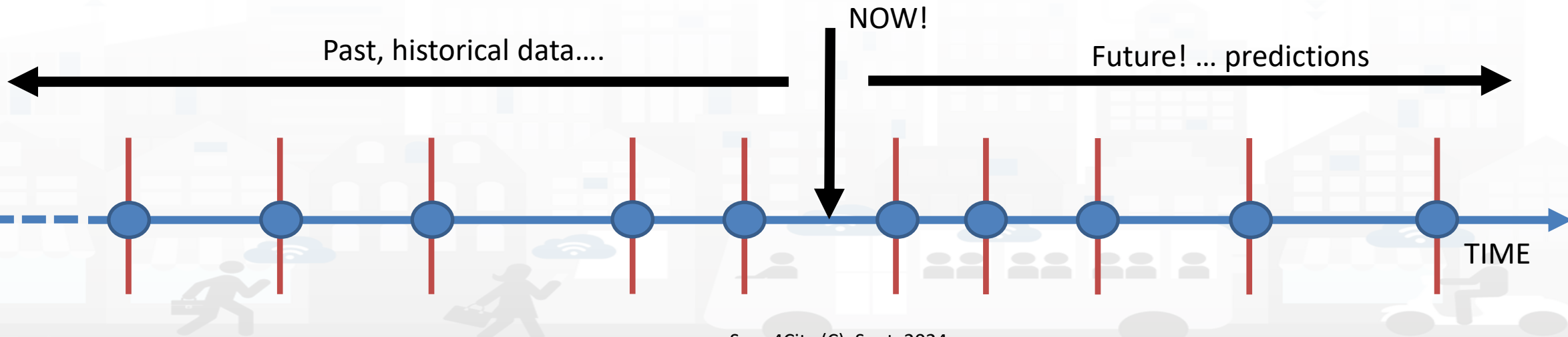

# HLT: Unified Classification for Data and Services

| IoT Device Variable, Sensor Device | All selected (15) | All selected (48) | All selected (27) | All selected (1499) | All selected (159) | All selected (15) | All selected (63) | Last Date  | Last Value          | All selected (2) | Last Check  | All selected (2)    | Ownership        |
|------------------------------------|-------------------|-------------------|-------------------|---------------------|--------------------|-------------------|-------------------|------------|---------------------|------------------|-------------|---------------------|------------------|
| High-Level Type                    | Nature            | Subnature         | Device/Model      | Broker              | Value Name         | Value Type        | Data Type         | Value Unit |                     |                  | Healthiness |                     |                  |
| IoT Device Variable                | IoTDevice         | IoTSensor         | devicetest1       | orionUNIFI          | temperature        | temperature       | float             | °C         |                     |                  | ●           | 2021-10-15 10:01:02 | private (My Own) |
| IoT Device Variable                | IoTDevice         | IoTSensor         | devicetest1       | orionUNIFI          | humidity           | humidity          | float             | #          |                     |                  | ●           | 2021-10-15 10:01:02 | private (My Own) |
| IoT Device Variable                | IoTDevice         | IoTSensor         | MyThermometer_001 | orionUNIFI          | temperature        | temperature       | float             | °C         |                     |                  | ●           | 2021-10-15 10:01:01 | private          |
| IoT Device Variable                | IoTDevice         | IoTSensor         | MyThermometer_001 | orionUNIFI          | humidity           | humidity          | float             | #          |                     |                  | ●           | 2021-10-15 10:01:01 | private          |
| IoT Device Variable                | IoTDevice         | IoTSensor         | adminTest1        | orionUNIFI          | temperature        | temperature       | string            | °C         | 2018-05-31 19:16:05 |                  | ●           | 2021-10-15 10:01:00 | private (My Own) |
| IoT Device Variable                | IoTDevice         | IoTSensor         | adminTest1        | orionUNIFI          | humidity           | humidity          | string            | %          | 2018-05-31 19:16:05 |                  | ●           | 2021-10-15 10:01:00 | private (My Own) |
| IoT Device Variable                | IoTDevice         | IoTSensor         | newmarcodev1      | orionUNIFI          | temperature        | temperature       | float             | °C         |                     |                  | ●           | 2021-10-15 10:00:59 | private          |
| IoT Device Variable                | IoTDevice         | IoTSensor         | newmarcodev1      | orionUNIFI          | humidity           | humidity          | float             | %          |                     |                  | ●           | 2021-10-15 10:00:59 | private          |

**High Level Types**

**Nature**

**Semantic  
Classific.**

**SubNature**

**Dev/Model name**

**Technical  
Source**

**Broker name**

**Value Name**

**Variables, names**

**Value Type**

**Data Type**

**Value Unit**

**Last Date/Time**

**Real  
Time**

**Last Value**

**Healthiness**

**Status**

**Last Check**

**Ownership  
Organization**

**For  
Admin**

## *Technical meaning*

<sup>Power</sup>  
Value Type

Value Unit

mW

Value Unit

KW

Data Type

Integer

Data Type

Float

Link to Friend Sensor as ServiceURI: Value Type

Value Unit

URL

Value Unit

KW

Data Type

String, URL

Data Type

Float



# Example of Energy and its Value Units

### Snap4City

User: roottooladmin1, Org: DISIT  
Role: RootAdmin, Level: 7

LOGOUT

- My Snap4City.org
- Tour Again
- ダッシュボード
- Dashboards (Public)
- My Dashboards in All Org.
- Dashboards of My Organization
- My Dashboards in My Organization
- My Data Dashboard Dev Kibana
- My Data Dashboard Kibana
- Extra Dashboard Widgets
- Notificator
- Data, my Data, OpenData
- Knowledge and Maps
- IOT Applications
- IOT Directory and Devices
- Resource Manager
  - View Resources
  - Managing Resources
  - Process Models
  - Processes in Execution
  - Process execution Archive
  - Dictionary Editor for Data Fields**
  - Doc: Resource Manager

### Dictionary Editor for Data Fields

+ Insert new Dictionary element

Filter by Dictionary type

Show 10

Search:

| Value Name       | Dictionary Type | Description                    | Data Types | Parent Value Name            | Child Value Name | Controls    |
|------------------|-----------------|--------------------------------|------------|------------------------------|------------------|-------------|
| Boats_and_shi... | subnature       | Boats And Ships Rental         |            | TransferServiceAndRenti...   |                  | EDIT DELETE |
| Bollard          | subnature       | Bollard                        |            | TransferServiceAndRenti...   |                  | EDIT DELETE |
| Bookshop         | subnature       | Bookshop                       |            | ShoppingAndService           |                  | EDIT DELETE |
| bool             | value unit      | boolean                        |            | dali_com_error, dali_dim...  |                  | EDIT DELETE |
| Botanical_and... | subnature       | Botanical & Zoolog. Gardens    |            | CulturalActivity             |                  | EDIT DELETE |
| Boxoffice        | subnature       | Boxoffice                      |            | Entertainment                |                  | EDIT DELETE |
| bpm              | value unit      | Beat per minute                |            | average_heart_rate, avera... |                  | EDIT DELETE |
| brightness_flag  | value type      | Brightness Flag                | string     |                              | #                | EDIT DELETE |
| broken_bikes     | value type      | Broken Bikes                   | integer    |                              | #                | EDIT DELETE |
| Building_and_... | subnature       | Build. & Indust. Clean. Activ. |            | Environment                  |                  | EDIT DELETE |

First << Prev 1...9 10 11...89 Next >> Last

**Value Type: Energy**

**Value Units:**

- Watt per hour
- KiloWatt per hour
- MegaWatt per hour

Snap4City (C), Sept. 2024

97

## Please note on: **Data Type**

- Value Types have only a few number of **Data Types** because they represent how the data area treated into the system
- Therefore: main Data Types are:
  - **Float**: numbers with decimals large as you like, etc.
  - **Integer**: numbers, booleans (0/1), on/off as 1/0, etc.
  - **String**: url, links, names, id, descriptions, status code, SURJ, etc.
  - **Json Objects**: structured data, vector, matrices, etc.
  - .....

## The Data Models can be simply instantiated from

- a) **FIWARE Smart Data Models**, versioning, and harvesting the standard repository
- b) **Entity Model / IoT Device Model** which are accessible into the Snap4City environment
- c) **Excel files by using Data Table tool**, which extracts the model from the excel table and automatically creates **Entity Model / IoT Device Model**, Entity Instances / IoT Devices and data attached to them
- d) Creating a **custom Entity Model / IoT Device Model** in standard Snap4City format via **Entity Directory / IoT Directory**

# Connections among Entities

| Where            | Entity Model<br>(IOT Device Model) | Entity Instance<br>(IOT Device)               | Entity Message<br>at 23-12-2019T20:15:00   | Entity Message<br>at 23-12-2019T20:30:12   |
|------------------|------------------------------------|-----------------------------------------------|--------------------------------------------|--------------------------------------------|
| Broker           | Broker: <b>OrionUNIFI</b>          |                                               |                                            |                                            |
| Broker           | Protocol: <b>NGSI</b>              |                                               |                                            |                                            |
| Info             | ID: string                         | ID: "park45"                                  | park45                                     | park45                                     |
| Position         | GPS: lat, long                     | GSP: 43.12, 11.34                             | GSP: 44.1256, 11.1234                      | GSP: 44.1259, 11.1233                      |
| Static attribute | Description: string                | Description: "parking massaia"                |                                            |                                            |
| Static attribute | MyAddInfoSURI: string              | MyAddInfoSURI:<br>"http://...../InfoPersonal" |                                            |                                            |
| Values           | dateObserved: Timestamp            |                                               | 23-12-2019T20:15:00                        | 23-12-2019T20:30:12                        |
| Values           | FreeSlots: Integer, #              |                                               | FreeSlots: 345                             | FreeSlots: 234                             |
| Values           | TodayCarSURI: string               |                                               | TodayCarSURI:<br>"http://...../CarNF126GD" | TodayCarSURI:<br>"http://...../CarGF789KK" |
| Values           | Temperature: float, celsius        |                                               | 34                                         | 34                                         |

# Model meaning

- **ID:** is the unique identifier for reconnecting Temporal Instances with registered Entity / Devices
- **Static Attributes:**
  - Are typically associated with instances of the IOT Device.  
E.g.:, You have a set of parking areas, each of them is located in a specific street, and has its one name, etc.
  - Different kinds of attributes can be set for each SubNature. Their definition has to be prepared into the Knowledge Base 😊 for automated indexing.
- **Values:** they are time varying variables (temporal values/instances)
  - They change over time, the timestamp of the time series is conventionally «dateObserved» in Snap4City
  - In new *SensorMobile* HLT, also GPS can be changing over time as in the MyKPI
- **NOTE for:**
  - **names/IDs:** Spaces or strange characters are not allowed in the. Please use simple alphanumeric strings, it is a limitation of many solutions including Orion Broker and increase interoperability of your data.
  - **Values of attributes and variables:** can be UTF8, but similarly, they do not accept: () <> “ ‘ ; = into values
  - [https://fiware-orion.readthedocs.io/en/master/user/forbidden\\_characters/index.html](https://fiware-orion.readthedocs.io/en/master/user/forbidden_characters/index.html)



Parts 3 and 5

# Entity / Device Model (2)

### Add new device

IOT Broker   Info   **Position**   Static Attributes   Values

**Latitude**  
Latitude is mandatory

**Longitude**  
Longitude is mandatory

Cancel   Confirm

### Edit Model - ChargingStationModel

General Info   IoT Broker   Static Attributes   Values

|                      |                         |                         |           |
|----------------------|-------------------------|-------------------------|-----------|
| chargingStateValue   | charging_state (Chargin | some coded status (sta  | string    |
| Value Name           | Value Type              | Value Unit              | Data Type |
| Ok                   | Ok                      | Ok                      |           |
| Refresh rate         | 900                     | Remove Value            |           |
| Healthiness Criteria | Healthiness Value       |                         |           |
| stationStateValue    | charging_station_state  | some coded status (sta  | string    |
| Value Name           | Value Type              | Value Unit              | Data Type |
| Ok                   | Ok                      | Ok                      |           |
| Refresh rate         | 900                     | Remove Value            |           |
| Healthiness Criteria | Healthiness Value       |                         |           |
| dateObserved         | timestamp (Timestamp    | timestamp in millisecon | string    |
| Value Name           | Value Type              | Value Unit              | Data Type |
| Ok                   | Ok                      | Ok                      |           |
| Refresh rate         | 900                     | Remove Value            |           |
| Healthiness Criteria | Healthiness Value       |                         |           |
| chargingState        | charging_state (Chargin | some coded status (sta  | string    |
| Value Name           | Value Type              | Value Unit              | Data Type |
| Ok                   | Ok                      | Ok                      |           |
| Refresh rate         | 900                     | Remove Value            |           |
| Healthiness Criteria | Healthiness Value       |                         |           |
| stationState         | charging_station_state  | some coded status (sta  | string    |
| Value Name           | Value Type              | Value Unit              | Data Type |
| Ok                   | Ok                      | Ok                      |           |
| Refresh rate         | 900                     | Remove Value            |           |
| Healthiness Criteria | Healthiness Value       |                         |           |

Add Value   Cancel   Confirm

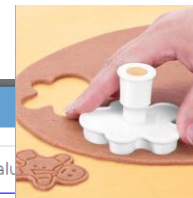

# SURI Connections

From a

- *Static* Attribute of an Entity Instance to another Entity Instance, as highlighted in green in previous table.
- *Dynamic Value/Variable* of an Entity Message of an Entity Instance to another Entity Instance, as highlighted in green in previous table.
- *the example reports a*
  - *static connection and*
  - *dynamic connection to change the car at a given timestamp, note also change of position and other parameters, if needed*

| p                                                                                                                                                 | o                                                                                                                                                                                       |
|---------------------------------------------------------------------------------------------------------------------------------------------------|-----------------------------------------------------------------------------------------------------------------------------------------------------------------------------------------|
| <a href="http://www.w3.org/1999/02/22-rdf-syntax-ns#type">http://www.w3.org/1999/02/22-rdf-syntax-ns#type</a>                                     | <a href="http://www.w3.org/ns/sosa/Sensor">http://www.w3.org/ns/sosa/Sensor</a>                                                                                                         |
| <a href="http://www.w3.org/1999/02/22-rdf-syntax-ns#type">http://www.w3.org/1999/02/22-rdf-syntax-ns#type</a>                                     | <a href="http://www.disit.org/km4city/schema#Traffic_sensor">http://www.disit.org/km4city/schema#Traffic_sensor</a>                                                                     |
| <a href="http://www.w3.org/ns/ssn/implements">http://www.w3.org/ns/ssn/implements</a>                                                             | <a href="http://www.disit.org/km4city/resource/iot/traffic">http://www.disit.org/km4city/resource/iot/traffic</a>                                                                       |
| <a href="http://www.disit.org/km4city/schema#hasAttribute">http://www.disit.org/km4city/schema#hasAttribute</a>                                   | <a href="http://www.disit.org/km4city/resource/iot/orionUNIFI/DISIT/METRO759/avgDistance">http://www.disit.org/km4city/resource/iot/orionUNIFI/DISIT/METRO759/avgDistance</a>           |
| <a href="http://www.disit.org/km4city/schema#hasAttribute">http://www.disit.org/km4city/schema#hasAttribute</a>                                   | <a href="http://www.disit.org/km4city/resource/iot/orionUNIFI/DISIT/METRO759/occupancy">http://www.disit.org/km4city/resource/iot/orionUNIFI/DISIT/METRO759/occupancy</a>               |
| <a href="http://www.disit.org/km4city/schema#hasAttribute">http://www.disit.org/km4city/schema#hasAttribute</a>                                   | <a href="http://www.disit.org/km4city/resource/iot/orionUNIFI/DISIT/METRO759/thresholdPerc">http://www.disit.org/km4city/resource/iot/orionUNIFI/DISIT/METRO759/thresholdPerc</a>       |
| <a href="http://www.disit.org/km4city/schema#hasAttribute">http://www.disit.org/km4city/schema#hasAttribute</a>                                   | <a href="http://www.disit.org/km4city/resource/iot/orionUNIFI/DISIT/METRO759/speedPercentile">http://www.disit.org/km4city/resource/iot/orionUNIFI/DISIT/METRO759/speedPercentile</a>   |
| <a href="http://www.disit.org/km4city/schema#hasAttribute">http://www.disit.org/km4city/schema#hasAttribute</a>                                   | <a href="http://www.disit.org/km4city/resource/iot/orionUNIFI/DISIT/METRO759/dateObserved">http://www.disit.org/km4city/resource/iot/orionUNIFI/DISIT/METRO759/dateObserved</a>         |
| <a href="http://www.disit.org/km4city/schema#hasAttribute">http://www.disit.org/km4city/schema#hasAttribute</a>                                   | <a href="http://www.disit.org/km4city/resource/iot/orionUNIFI/DISIT/METRO759/avgTime">http://www.disit.org/km4city/resource/iot/orionUNIFI/DISIT/METRO759/avgTime</a>                   |
| <a href="http://www.disit.org/km4city/schema#hasAttribute">http://www.disit.org/km4city/schema#hasAttribute</a>                                   | <a href="http://www.disit.org/km4city/resource/iot/orionUNIFI/DISIT/METRO759/concentration">http://www.disit.org/km4city/resource/iot/orionUNIFI/DISIT/METRO759/concentration</a>       |
| <a href="http://www.disit.org/km4city/schema#hasAttribute">http://www.disit.org/km4city/schema#hasAttribute</a>                                   | <a href="http://www.disit.org/km4city/resource/iot/orionUNIFI/DISIT/METRO759/vehicleFlow">http://www.disit.org/km4city/resource/iot/orionUNIFI/DISIT/METRO759/vehicleFlow</a>           |
| <a href="http://www.disit.org/km4city/schema#hasAttribute">http://www.disit.org/km4city/schema#hasAttribute</a>                                   | <a href="http://www.disit.org/km4city/resource/iot/orionUNIFI/DISIT/METRO759/averageSpeed">http://www.disit.org/km4city/resource/iot/orionUNIFI/DISIT/METRO759/averageSpeed</a>         |
| <a href="http://www.disit.org/km4city/schema#hasAttribute">http://www.disit.org/km4city/schema#hasAttribute</a>                                   | <a href="http://www.disit.org/km4city/resource/iot/orionUNIFI/DISIT/METRO759/congestionLevel">http://www.disit.org/km4city/resource/iot/orionUNIFI/DISIT/METRO759/congestionLevel</a>   |
| <a href="http://www.disit.org/km4city/schema#hasAttribute">http://www.disit.org/km4city/schema#hasAttribute</a>                                   | <a href="http://www.disit.org/km4city/resource/iot/orionUNIFI/DISIT/METRO759/anomalyLevel">http://www.disit.org/km4city/resource/iot/orionUNIFI/DISIT/METRO759/anomalyLevel</a>         |
| <a href="http://www.w3.org/ns/sosa/observes">http://www.w3.org/ns/sosa/observes</a>                                                               | <a href="http://www.disit.org/km4city/resource/value_type/average_vehicle_distance">http://www.disit.org/km4city/resource/value_type/average_vehicle_distance</a>                       |
| <a href="http://www.w3.org/ns/sosa/observes">http://www.w3.org/ns/sosa/observes</a>                                                               | <a href="http://www.disit.org/km4city/resource/value_type/average_vehicle_speed">http://www.disit.org/km4city/resource/value_type/average_vehicle_speed</a>                             |
| <a href="http://www.w3.org/ns/sosa/observes">http://www.w3.org/ns/sosa/observes</a>                                                               | <a href="http://www.disit.org/km4city/resource/value_type/average_vehicle_time">http://www.disit.org/km4city/resource/value_type/average_vehicle_time</a>                               |
| <a href="http://www.w3.org/ns/sosa/observes">http://www.w3.org/ns/sosa/observes</a>                                                               | <a href="http://www.disit.org/km4city/resource/value_type/vehicle_concentration">http://www.disit.org/km4city/resource/value_type/vehicle_concentration</a>                             |
| <a href="http://www.w3.org/ns/sosa/observes">http://www.w3.org/ns/sosa/observes</a>                                                               | <a href="http://www.disit.org/km4city/resource/value_type/vehicle_speed_percentile">http://www.disit.org/km4city/resource/value_type/vehicle_speed_percentile</a>                       |
| <a href="http://www.w3.org/ns/sosa/observes">http://www.w3.org/ns/sosa/observes</a>                                                               | <a href="http://www.disit.org/km4city/resource/value_type/vehicle_threshold_perc">http://www.disit.org/km4city/resource/value_type/vehicle_threshold_perc</a>                           |
| <a href="http://www.w3.org/ns/sosa/observes">http://www.w3.org/ns/sosa/observes</a>                                                               | <a href="http://www.disit.org/km4city/resource/value_type/vehicle_flow">http://www.disit.org/km4city/resource/value_type/vehicle_flow</a>                                               |
| <a href="http://www.w3.org/ns/sosa/observes">http://www.w3.org/ns/sosa/observes</a>                                                               | <a href="http://www.disit.org/km4city/resource/value_type/timestamp">http://www.disit.org/km4city/resource/value_type/timestamp</a>                                                     |
| <a href="http://www.w3.org/ns/sosa/observes">http://www.w3.org/ns/sosa/observes</a>                                                               | <a href="http://www.disit.org/km4city/resource/value_type/anomaly_level">http://www.disit.org/km4city/resource/value_type/anomaly_level</a>                                             |
| <a href="http://www.w3.org/ns/sosa/observes">http://www.w3.org/ns/sosa/observes</a>                                                               | <a href="http://www.disit.org/km4city/resource/value_type/traffic_congestion">http://www.disit.org/km4city/resource/value_type/traffic_congestion</a>                                   |
| <a href="http://www.w3.org/ns/ssn/hasSystemCapability">http://www.w3.org/ns/ssn/hasSystemCapability</a>                                           | <a href="http://www.disit.org/km4city/resource/iot/orionUNIFI/DISIT/METRO759/systemCapability">http://www.disit.org/km4city/resource/iot/orionUNIFI/DISIT/METRO759/systemCapability</a> |
| <a href="http://purl.oclc.org/NET/UNIS/fiware/iot-lite#exposedBy">http://purl.oclc.org/NET/UNIS/fiware/iot-lite#exposedBy</a>                     | <a href="http://www.disit.org/km4city/resource/iot/orionUNIFI">http://www.disit.org/km4city/resource/iot/orionUNIFI</a>                                                                 |
| <a href="http://www.disit.org/km4city/schema#protocol">http://www.disit.org/km4city/schema#protocol</a>                                           | "ngsi"                                                                                                                                                                                  |
| <a href="http://www.disit.org/km4city/schema#format">http://www.disit.org/km4city/schema#format</a>                                               | "json"                                                                                                                                                                                  |
| <a href="http://www.w3.org/2003/01/geo/wgs84_pos#long">http://www.w3.org/2003/01/geo/wgs84_pos#long</a>                                           | 11.25673                                                                                                                                                                                |
| <a href="http://schema.org/addressLocality">http://schema.org/addressLocality</a>                                                                 | "FIRENZE"                                                                                                                                                                               |
| <a href="http://schema.org/name">http://schema.org/name</a>                                                                                       | "METRO759"                                                                                                                                                                              |
| <a href="http://schema.org/streetAddress">http://schema.org/streetAddress</a>                                                                     | "Lavagnini P.zza Della Liberta' (38)"                                                                                                                                                   |
| <a href="http://www.w3.org/2003/01/geo/wgs84_pos#lat">http://www.w3.org/2003/01/geo/wgs84_pos#lat</a>                                             | 43.78278                                                                                                                                                                                |
| <a href="http://www.disit.org/km4city/schema#isInRoad">http://www.disit.org/km4city/schema#isInRoad</a>                                           | <a href="http://www.disit.org/km4city/resource/RT04801703772TO">http://www.disit.org/km4city/resource/RT04801703772TO</a>                                                               |
| <a href="http://www.w3.org/2003/01/geo/wgs84_pos#geometry">http://www.w3.org/2003/01/geo/wgs84_pos#geometry</a>                                   | "POINT(11.256730079651 43.782779693604)""^<a href="http://www.openlinksw.com/schemas/virttrdf#Geometry">                                                                                |
| <a href="http://www.disit.org/km4city/schema#model">http://www.disit.org/km4city/schema#model</a>                                                 | "metrotrafficsensor"                                                                                                                                                                    |
| <a href="http://www.disit.org/km4city/schema#producer">http://www.disit.org/km4city/schema#producer</a>                                           | "metro"                                                                                                                                                                                 |
| <a href="http://www.disit.org/km4city/resource/iot/traffic_ma#organization">http://www.disit.org/km4city/resource/iot/traffic_ma#organization</a> | "DISIT"                                                                                                                                                                                 |

- They are triples
- Subject-  
predicate-  
Object
  - Subject=SURI
  - Predicate=p
  - Object = o

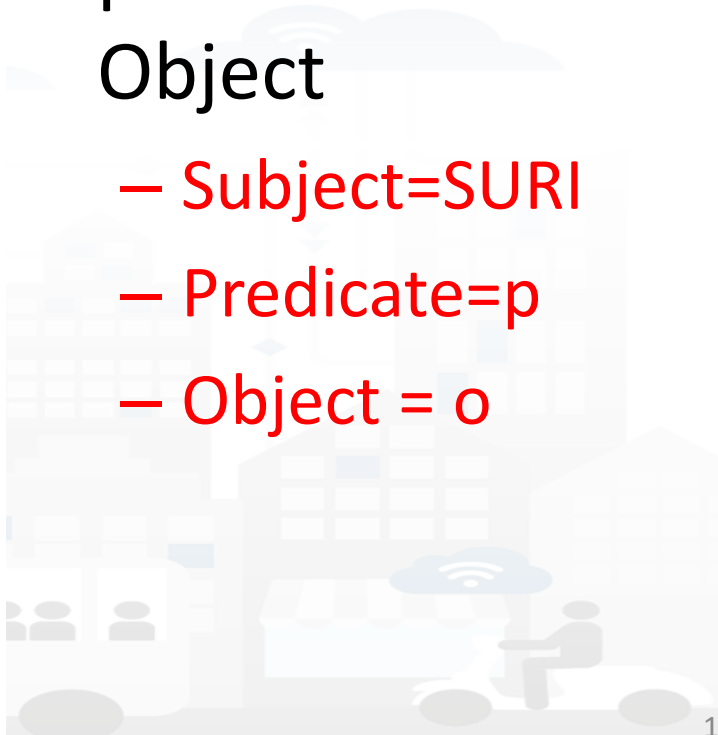



TOP

# *References/Links to Entities Instances / IoT Devices*



# Relationships among Devices/Entities, POI and MyKPI

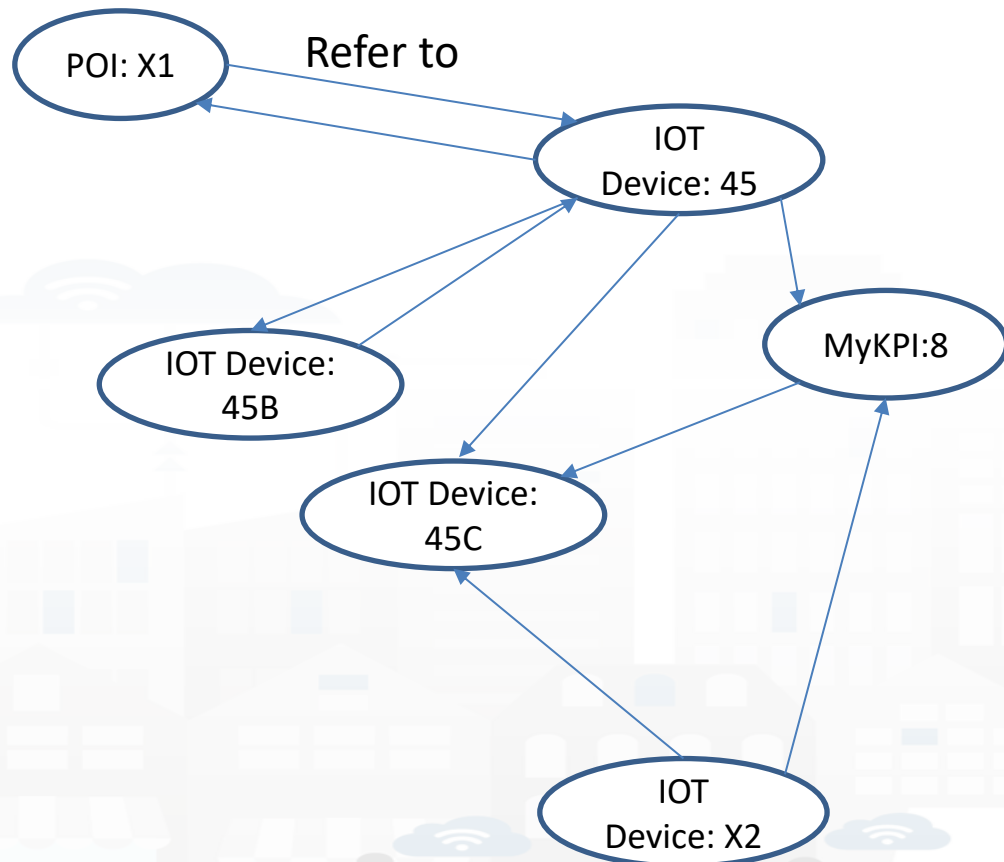

- **Devices and POI** may refer to:
  - IoT Devices/Entities, POI, MyKPI, Heatmaps, etc.
  - The Links may change over time
- **MultiDataMap** can be used for navigation:
  - Among: IoT Devices, POI, MyKPI
  - Automated focus
  - Accessing Time Trends

# IoT device with References to other and MyKPI

```
{  
  "id": "ThermalBOX1",  
  "type": "thermalbox",  
  "dateObserved": {"type": "string", "value": "2022-02-24T17:15:34.609Z"},  
  "latitude": {"type": "float", "value": "43.76965"},  
  "longitude": {"type": "float", "value": "11.25570"},  
  "SHTdevice": {"type": "string",  
    "value": "http://www.disit.org/km4city/resource/iot/orion/Firenze2/Firenze/SHT20lab_new"},  
  "cam51count": {"type": "string", "value": "datamanager/vapi/v1/poidata/17058000"},  
  "cam52count": {"type": "string", "value": "datamanager/vapi/v1/poidata/17058001"},  
  ...  
}
```

*Value Type: Identifier*

*Value Unit: ServiceURI*

*Data Type: String*

*//any query: such as those of the Selector*

# Data Modeling example1



# Example 1

**IoT Device Model: Driver**  
**Nature:**.....  
**Subnature:** .....

**Lat,lon:** Default (they do not need to be specified in the variables, they are provided by default, but values have to be imposed at the instantiation of the device from model), they are float  
**Device in Mobility:** No (the variable do not need to be specified, while the value has to be set to state if the Lat,Lon are going to change, moving the device or not)

| Value_name          | Value Type       | Value Unit             | Data Type     |
|---------------------|------------------|------------------------|---------------|
| <b>dateObserved</b> | <b>Timestamp</b> | <b>Timestamp in ms</b> | <b>String</b> |
| identifier          | ID               | text                   | String        |
| name                | entity           | text                   | String        |
| surname             | entity           | text                   | String        |
| age                 | age              | number                 | Integer       |
| sex                 | status           | some coded status      | String        |
| language            | entity           | text                   | String        |
| email               | entity           | text                   | String        |
| phone               | entity           | text                   | String        |
| address             | entity           | text                   | String        |
| locality            | entity           | text                   | String        |
| city                | entity           | text                   | String        |
| nationality         | entity           | text                   | String        |
| civicNmber          | entity           | text                   | String        |
| dateofBorn          | DateTime         | Timestamp in ms        | String        |
| gender              | status           | some coded status      | String        |
| driverHelthiness    | Identifier       | ServiceURI             | String        |
| driverEvent         | Identifier       | ServiceURI             | String        |
| driverAnalysis      | Identifier       | ServiceURI             | String        |
| Vechicle            | Identifier       | ServiceURI             | String        |

# Example 2

| IoT Device Model: driverHelthiness |            |                 |           |
|------------------------------------|------------|-----------------|-----------|
| Nature:.....                       |            |                 |           |
| Subnature: .....                   |            |                 |           |
| Lat,lon: .....                     |            |                 |           |
| Device in Mobility: .....          |            |                 |           |
| Value_name                         | Value Type | Value Unit      | Data Type |
| dateObserved                       | Timestamp  | Timestamp in ms | String    |
| kind                               |            |                 |           |
| levelAttentionFactor1              |            |                 |           |
| levelAttentionFactor2              |            |                 |           |
|                                    |            |                 |           |
|                                    |            |                 |           |
| driver                             | Identifier | ServiceURI      | String    |

# Example 3

| IoT Device Model: Vehicle |              |                   |           |
|---------------------------|--------------|-------------------|-----------|
| Nature:.....              |              |                   |           |
| Subnature: .....          |              |                   |           |
| Lat,lon: .....            |              |                   |           |
| Device in Mobility: ..... |              |                   |           |
| Value_name                | Value Type   | Value Unit        | Data Type |
| dateObserved              | Timestamp    | Timestamp in ms   | String    |
| producer                  | entity       | text              | String    |
| model                     | entity       | text              | String    |
| plate                     | entity       | text              | String    |
| companyID                 | entity       | text              | String    |
| velocity                  | velocity     | km/h              | float     |
| acceleration              | acceleration | m/s <sup>2</sup>  | float     |
| Status                    | status       | some coded status | String    |
| energyLevel               | energy level | percentage        | Float     |
| kmTotal                   | distance     | km                | Float     |
| thankLevel                | energy level | percentage        | Float     |
| vehicleEvent              | Identifier   | ServiceURI        | String    |

# Example 4

## IoT Device Model: VehicleEvent

Nature:.....

Subnature: .....

Lat,lon: .....

Device in Mobility: .....

| Value_name   | Value Type | Value Unit        | Data Type |
|--------------|------------|-------------------|-----------|
| dateObserved | Timestamp  | Timestamp in ms   | String    |
| eventID      | ID         | text              | String    |
| eventKind    | status     | some coded status | String    |
| status       | status     | some coded status | String    |
| vehicle      | Identifier | ServiceURI        | String    |



**legenda**

- Entity Instance
- Entity Model
- Entity Messages with dateObserved

**Data Model of the Driver**

- Name: string
- Surname: string
- Age: number
- Weight: number
- Phone: string
- Email: string
- DriverAnalysisID: ServiceURI
- .....

**Driver: user45**

- Name: David
- Surname: Smith
- Age: 45
- Weight: 78 Kg
- Phone: +49345096103
- Email: [david89@gmail.com](mailto:david89@gmail.com)
- DriverAnalysis: <http://.../user45driveranalysis>
- .....

**DriverAnalysis: user45driveranalysis**

- DriverID: <http://.../user45>
- dateObserved: 25-04-2022T12:00:00
- Status: "bad"
- Location: truck
- Doctor: null
- Tools: Eyetrack
- .....

**DriverAnalysis: user45driveranalysis**

- DriverID: <http://.../user45>
- dateObserved: 12-03-2022T12:00:00
- Status: "none"
- Location: null
- Doctor: null
- Tools: null
- .....

**DriverAnalysis: user45driveranalysis**

- DriverID: <http://.../user45>
- dateObserved: 22-03-2022T12:00:00
- Status: "good"
- Location: room45
- Doctor: <https://.....>
- Tools: null
- .....

Register to instantiate

Register to instantiate

Write SURIs to create cross references

New update on user45driveranalysis by sending a message

New update on user45driveranalysis by sending a message

# Example of Data Model Diagram

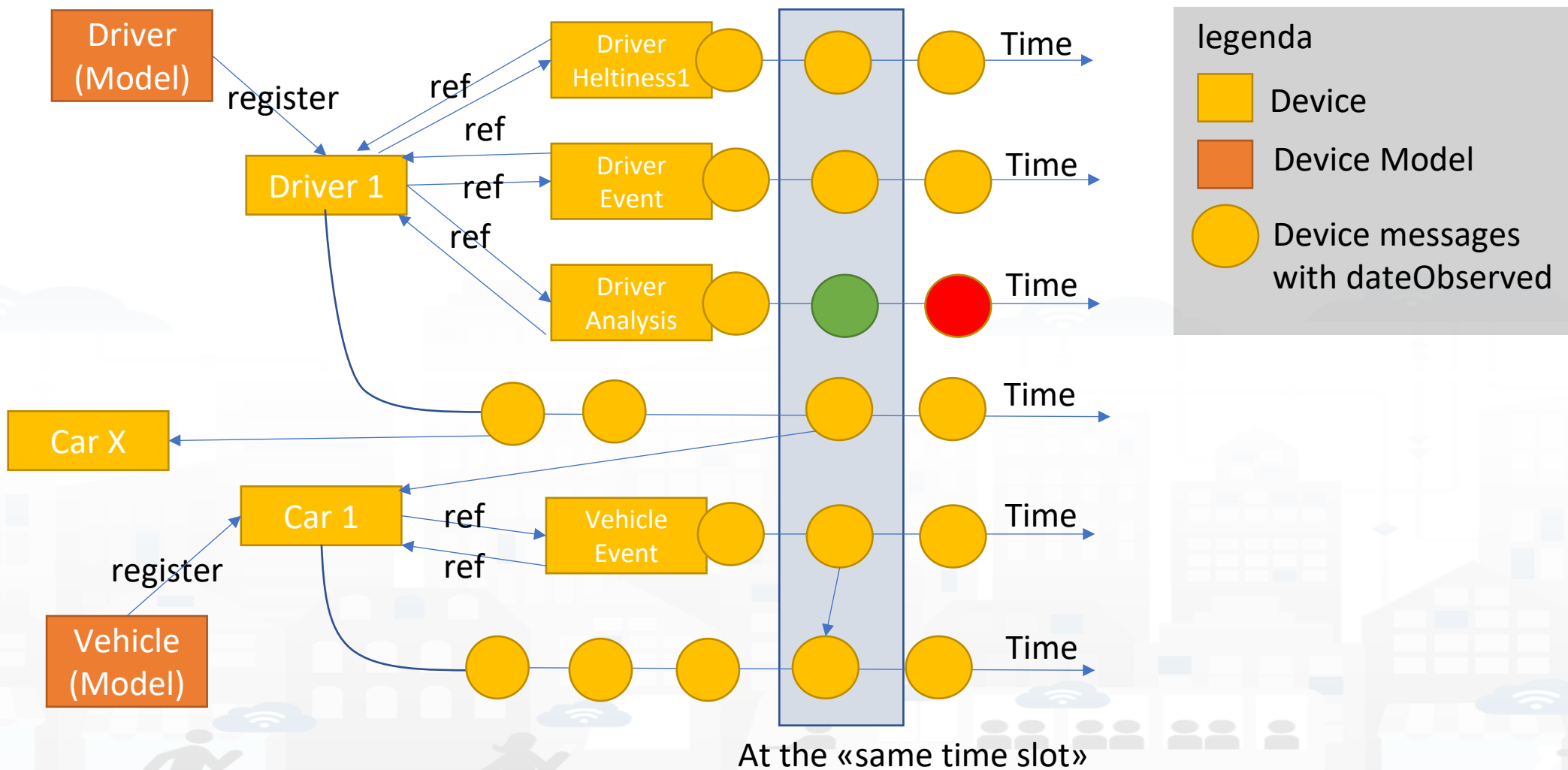

# Example of Data Model Diagram

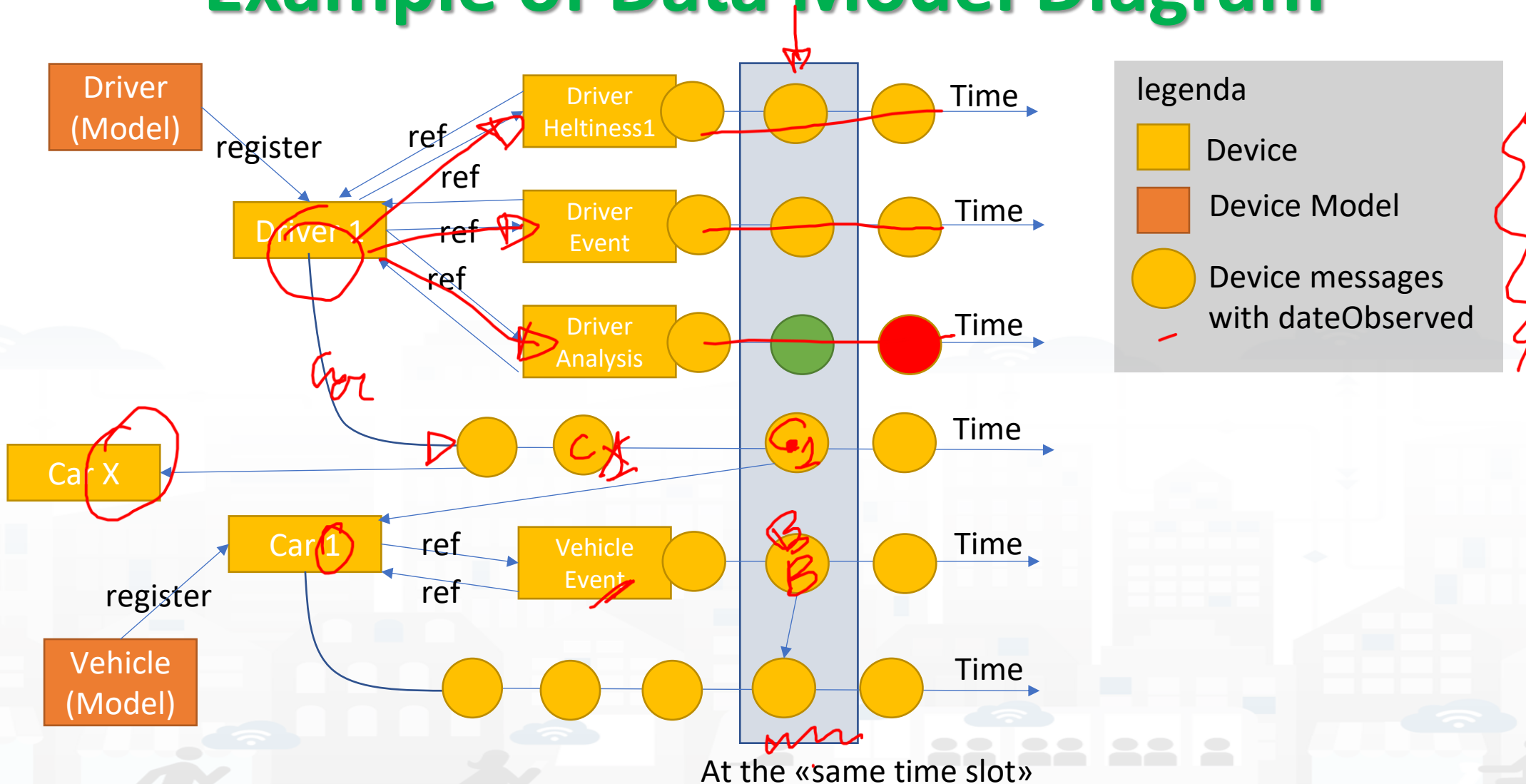

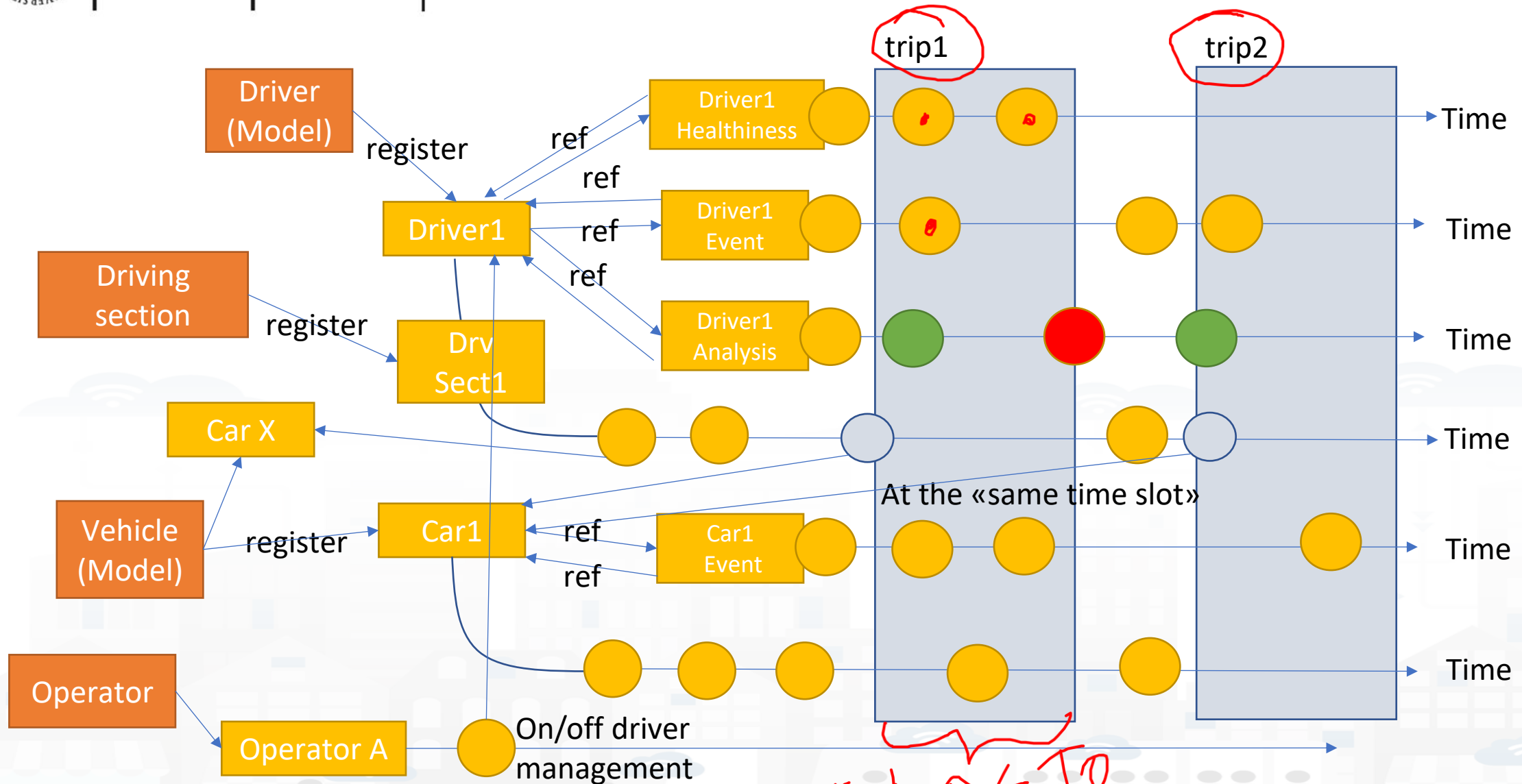

TOP

# ***TOOLS for Data Design and HLT Exploitation***

Part 2

Part 5



# Snap4City Tools

vs

# Development Life Cycle

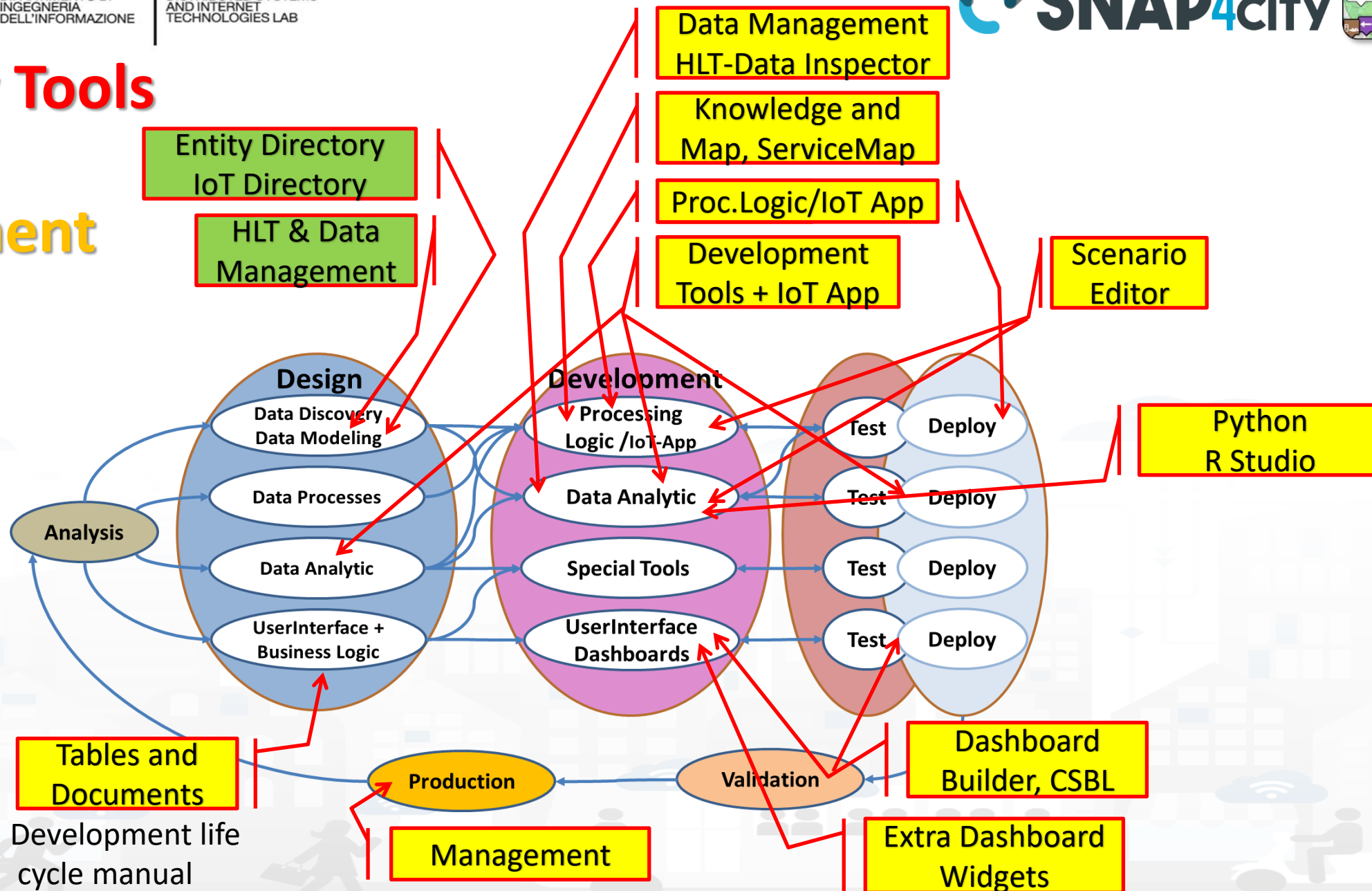

# Snap4city Data Ingestion Diagram

storage

Manual or automated  
Registration  
of Entities/Devices

**Entity/IoT  
Directory**

registration  
triples

NGSI



**Orion Broker**

IoT Orion Broker

IoT Orion Broker

IoT Orion Broker

**Brokers**

subscription note

NGSI

Real Time

**Knowledge Base**

Semantic Reasoners

Semantic Reasoners

SURI Link

**Indexing and Aggregating**

NIFI, OpenSearch

**Data Managers**

Data Managers

Entity Inspector



A number of KB  
federated



**Federation**  
Smart City API, ASCAPI

**API Manager**

Cluster of **OpenSearch**  
for storage with in  
front a cluster of  
NIFI

**Platform Automation:**

IoT Apps, Proc.Logics,  
Python, ...



**Data Analytics: ML, AI, XAI**



**Platform Control and Management**

Massive data flow  
entering

Massive data flow  
exiting

# Any Entity has a Semantic Classification

## Nature

- Accommodation +
- Advertising +
- AgricultureAndLivestock +
- CivilAndEdilEngineering +
- CulturalActivity +
- EducationAndResearch +
- Emergency +
- Entertainment +
- Environment +
- FinancialService +
- GovernmentOffice +
- HealthCare +
- IndustryAndManufacturing +
- IoTDevice +
- MiningAndQuarrying +
- ShoppingAndService +
- TourismService +
- TransferServiceAndRenting +
- UtilitiesAndSupply +
- Wholesale +
- WineAndFood +

## SubNature

- EducationAndResearch -
  - Educational\_support\_activities
  - Higher\_education
  - Language\_courses
  - Performing\_arts\_schools
  - Post\_secondary\_education
  - Pre\_primary\_education
  - Primary\_education
  - Private\_high\_school
  - Private\_infant\_school
  - Private\_junior\_high\_school

# SKOS

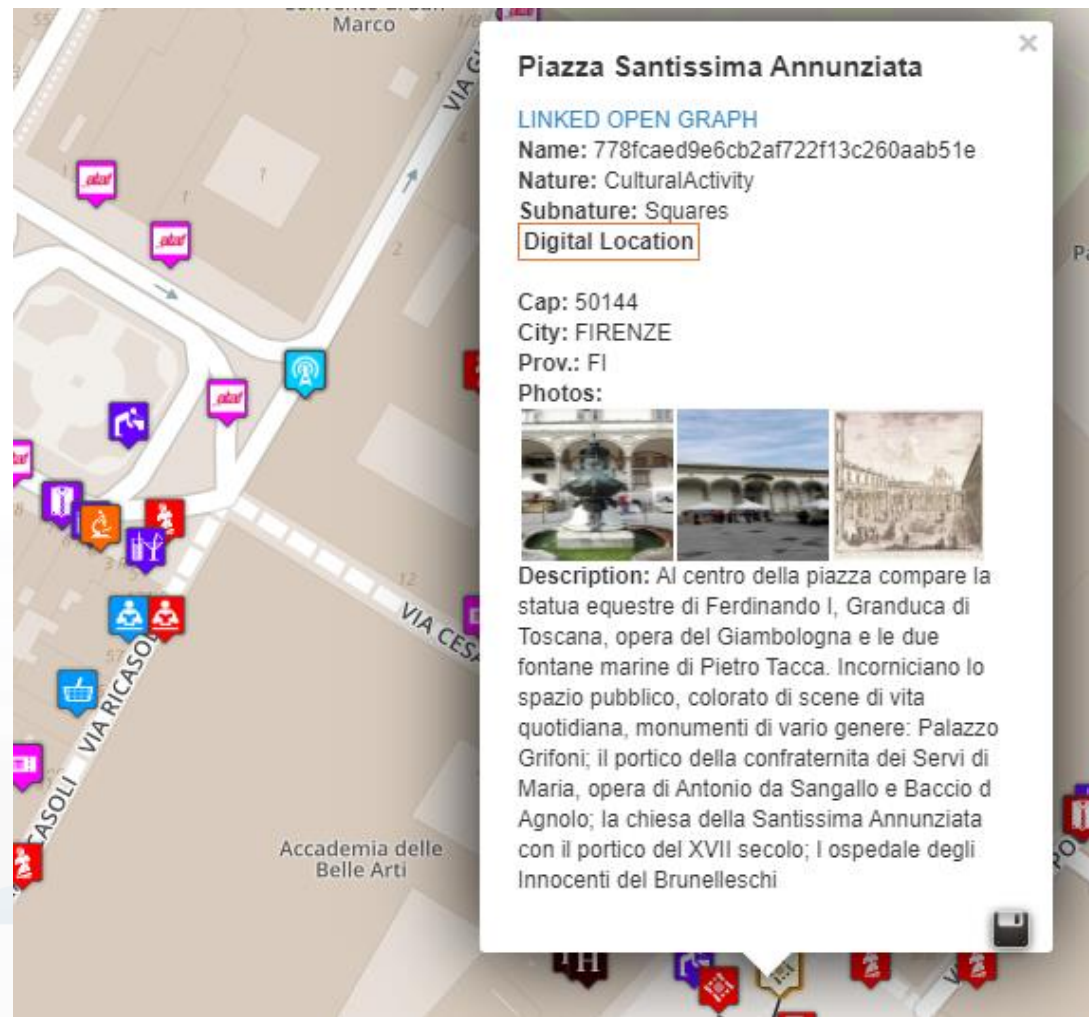



# Entity / Iot Directory: User Role

Entity Directory and Devices

- My IOT Sensors and Actuators
- IOT Sensors and Actuators
- Entity Instances, IoT Devices
- IOT Brokers
- FIWARE Smart Data Models
- Entity Models/IoT Devices
- IOT Devices Bulk Registration
- Doc: IOT Directory and Devices
- Create an IOT Device Instance
- Create an IOT Device Model
- Add an IOT Device into Snap4City

Entity Models/IoT Devices

302 MODELS

Show 10 entries

Search:

New Model

|   | Device Model                        | Description                                                                          | Ownership | Organization | Kind     | Producer     | Device Type      | Edit | Delete | View |
|---|-------------------------------------|--------------------------------------------------------------------------------------|-----------|--------------|----------|--------------|------------------|------|--------|------|
| + | Raspberry snap4city 1               | Raspberry PI 3 Model B Scheda madre CPU 1.2 GHz Quad Core, 1 GB RAM                  | DELEGATED | DISIT        | sensor   | Raspberry PI | Ambiental        |      |        | VIEW |
| + | Raspberry snap4city 2               | Raspberry PI 3 Model B Scheda madre CPU 1.2 GHz Quad Core, 1 GB RAM                  | DELEGATED | DISIT        | sensor   | Raspberry PI | Ambiental        |      |        | VIEW |
| + | Arduino Uno                         | Arduino Model B Scheda madre CPU 1.2 GHz Quad Core, 1 GB RAM                         | DELEGATED | DISIT        | sensor   | Arduino      | Ambiental        |      |        | VIEW |
| + | Arduino uno-bis                     | Arduino Model B Scheda madre CPU 1.2 GHz Quad Core, 1 GB RAM                         | DELEGATED | DISIT        | sensor   | Arduino      | Ambiental        |      |        | VIEW |
| + | sigfox                              | SigFox Model B Scheda madre CPU 1.2 GHz Quad Core, 1 GB RAM                          | DELEGATED | DISIT        | sensor   | SigFox       | Ambiental        |      |        | VIEW |
| + | Snap4AllButtonV1                    | Snap4AllButtonV1                                                                     | DELEGATED | DISIT        | sensor   | Snap4All     | Snap4AllButtonV1 |      |        | VIEW |
| + | Raspberry snap4city 1 - Certificate | Raspberry PI 3 Model B Scheda madre CPU 1.2 GHz Quad Core, 1 GB RAM with certificate | DELEGATED | DISIT        | sensor   | Raspberry PI | Ambiental        |      |        | VIEW |
| + | datacenter3dht22                    | datacenter3dht22                                                                     | DELEGATED | DISIT        | sensor   | disit        | raspberry        |      |        | VIEW |
| + | Thermometer                         | This model represents a generic device that can measure a temperature                | DELEGATED | DISIT        | sensor   | Generic      | Ambiental        |      |        | VIEW |
| + | AirConditioner                      | Generic model representing a simple conditioner with only the status attribute       | DELEGATED | DISIT        | actuator | Generic      | Ambiental        |      |        | VIEW |

Showing 1 to 10 of 89 entries

Previous 1 2 3 4 5 ... 9 Next

# Entity Directory for Beginners

- Browse and see models and entities/devices of other users, that published them
- Create your Entity / Device Models
  - User the dictionary approach: value type, data type, value unit
  - Manage delegation of the models and ownership
- Create your Entities / Devices from scratch and/or from models
  - Several models are ready to be used.....
- Send a Message to a Device, thus to the broker
- Read a Message from the Broker, see the message format expected to be sent at the Broker in NGSI format

# IoT Device Model and Devices Data

## Dictionary: updated at 11/2022

<https://www.snap4city.org/818>

### IoT Device Model and Devices Data Dictionary: updated at 11/2022

View Edit Track Access control Convert

Any update and addition to the dictionary of snap4city.org has to be requested to snap4city@disit.org

if you have your own instance of the platform you can define your own dictionary and request a copy of the snap4city.org dictionary

The dictionary is used into the IoT Device Model definition, in mapping smart data models, and in creating full custom devices.

[https://www.snap4city.org/drupal/sites/default/files/image\\_from\\_word/fil...](https://www.snap4city.org/drupal/sites/default/files/image_from_word/fil...)

| value type                   | Description                  | possible value Units                       | Possible Data Types |
|------------------------------|------------------------------|--------------------------------------------|---------------------|
| actuator_canceller           | Actuator Canceller           |                                            | string              |
| actuator_deleted             | Actuator Deleted             |                                            | integer             |
| actuator_deletion_date       | Actuator Deletion Date       | timestamp                                  | string              |
| air_quality_index            | Air quality index            |                                            | float               |
| altitude                     | Altitude                     | m                                          | float, integer      |
| angle                        | angle                        | deg                                        | float               |
| annual_C6H6_average          | annual_C6H6_average          | ppm, mg/m <sup>3</sup> , µg/m <sup>3</sup> | float               |
| annual_C6H6_exceedance_count | annual_C6H6_exceedance_count | #                                          | integer, float      |
| annual_CO_average            | annual_CO_average            | ppm, mg/m <sup>3</sup> , µg/m <sup>3</sup> | float               |
| annual_CO_exceedance_count   | annual_CO_exceedance_count   | #                                          | integer, float      |
| annual_NO2_average           | annual_NO2_average           | ppm, mg/m <sup>3</sup> , µg/m <sup>3</sup> | float               |
| annual_NO2_exceedance_count  | annual_NO2_exceedance_count  | #                                          | integer, float      |
| annual_O3_average            | annual_O3_average            | ppm, mg/m <sup>3</sup> , µg/m <sup>3</sup> | float               |

# Data management, HLT

- Data Inspector
- MyKPI.....
- My Groups of Entities
- HeatMap Manager
- BIM Server.....
- Open Data...
- For user kind of users, other Managers:
  - ODM, File, TV CAM, Traffic Flow, .....

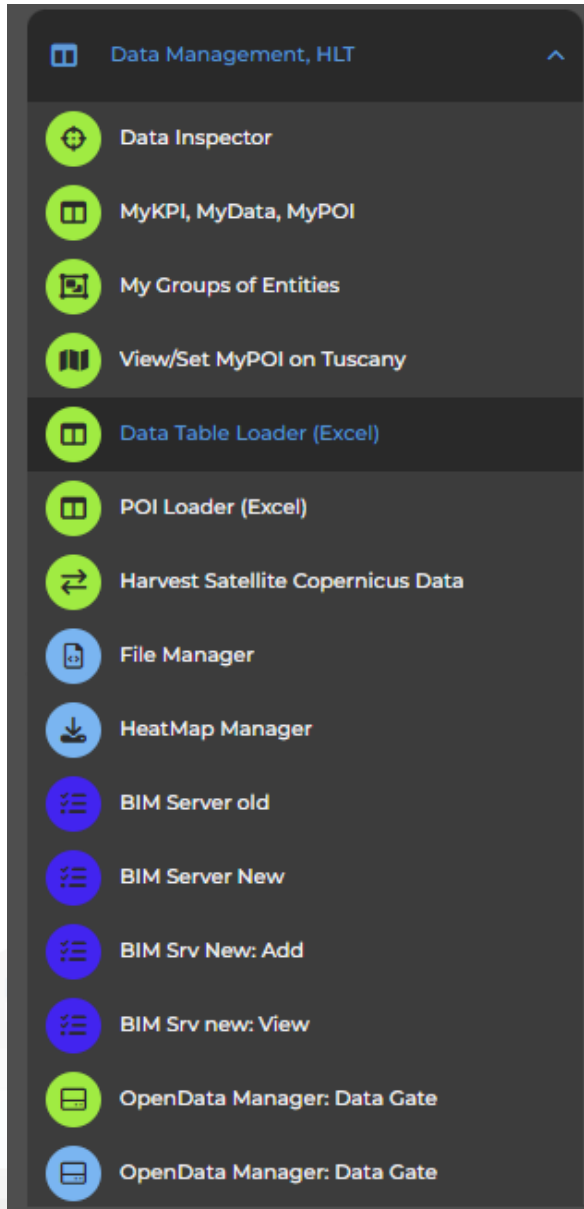

TOP

# Design & Develop: Data Processes Proc. Logic / IoT App



Part 3  
Part 5

# Activities for IoT App data processes

- **Data Ingestion, gathering, harvesting, grabbing**
- **Data Transformation, transcoding, decoding, converting, reformatting, ..**
- **Data load to storage, retrieve from storage**
  - the load is typically performed loading data on some Internal Orion Broker V2/LD, or on some MyKPI storage
  - the retrieval is typically performed using one of the several query / search nodes.
  - Many other kinds of storage connections are accessible in Snap4City Proc.Logic / IoT Apps
- **Data Production, generation, reformatting, etc.**
- **Data Publication, post in other channels of any kind, etc.**
- **Server Side Business Logic as described in the following**

# Development Life Cycle Smart Solutions

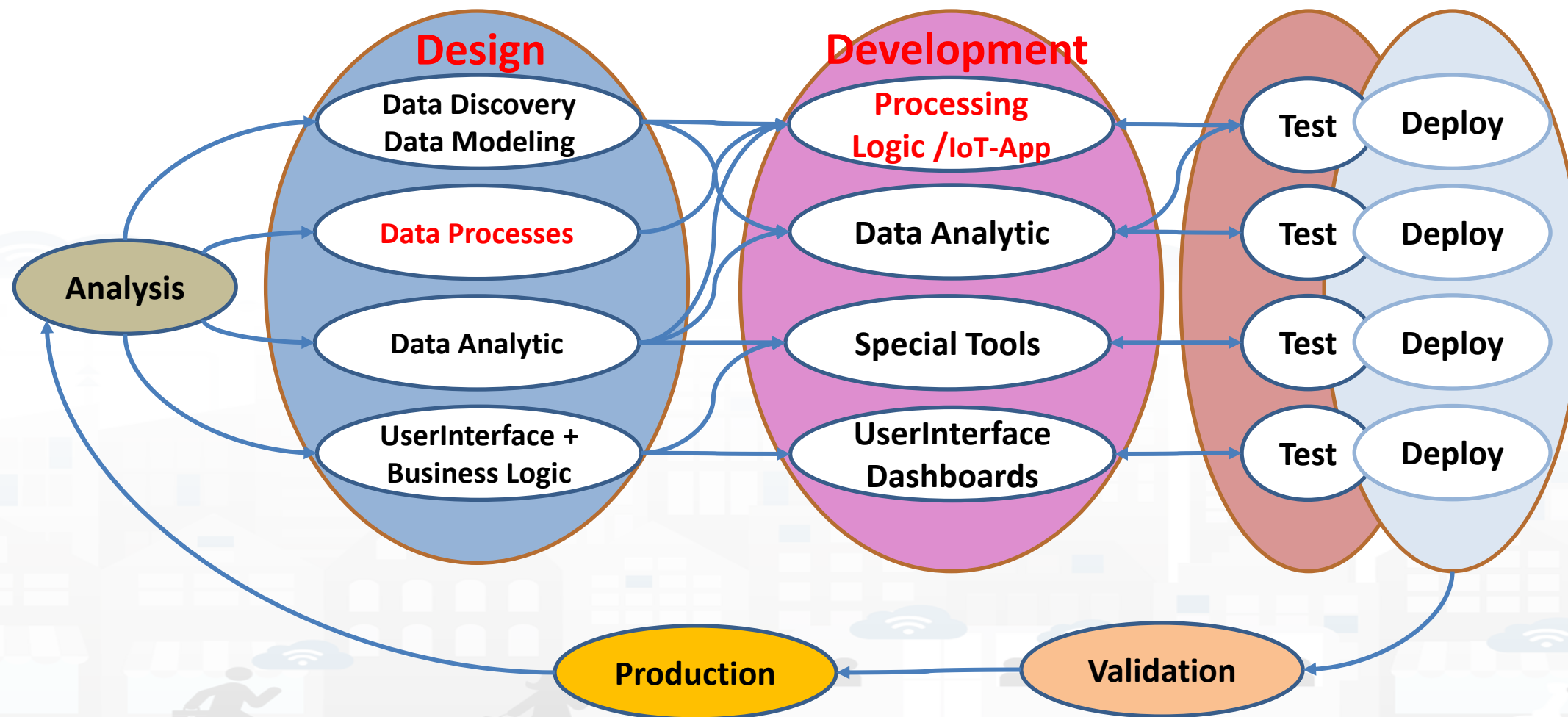

# Snap4City Tools

vs

# Development Life Cycle

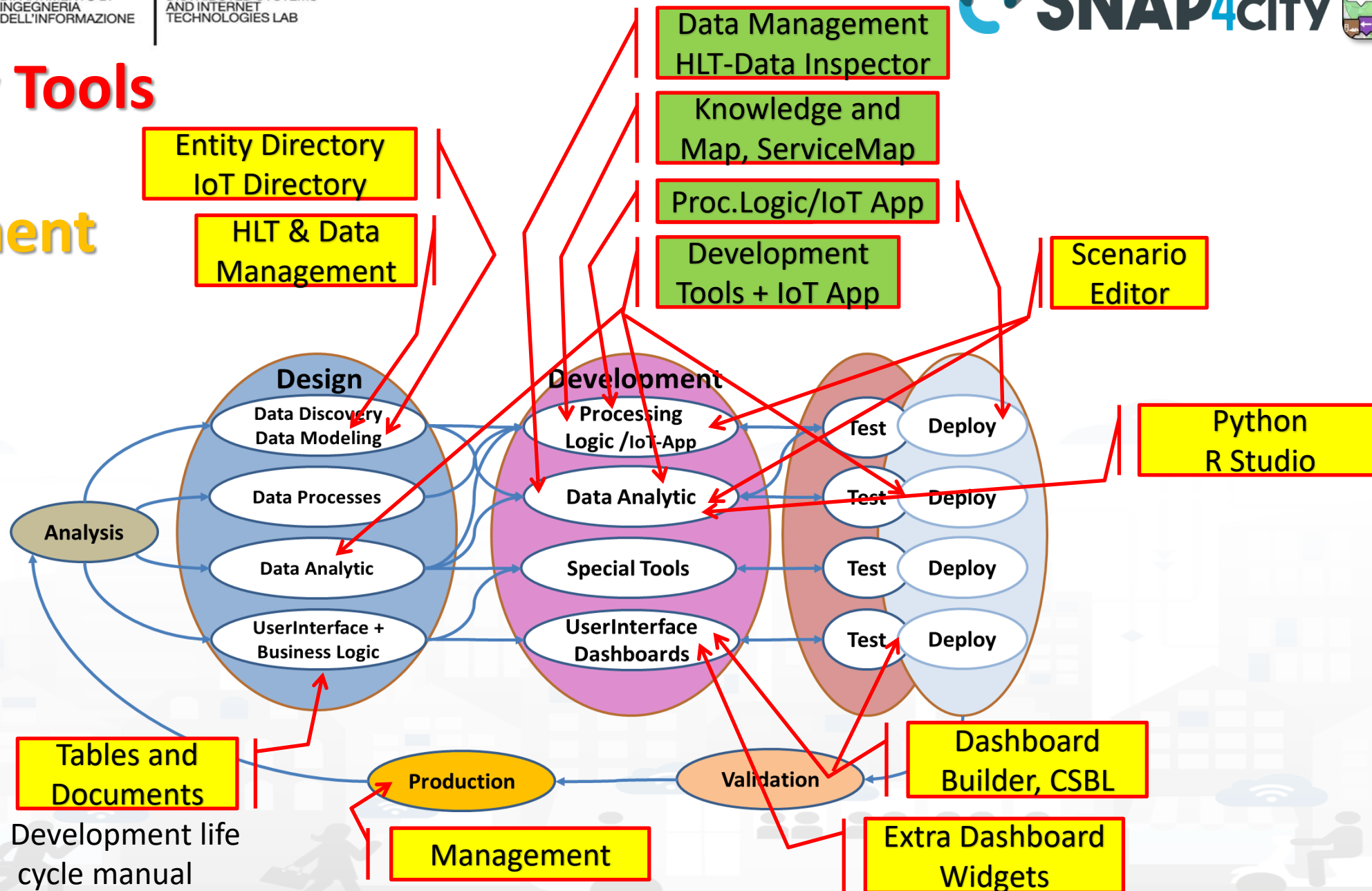



TOP

# *Design: Data Processes*

Part 3

Part 5



# How to Design

- 1. Business Logic** is going to be implemented in Proc.Logic (IoT App), with a set of flows.
- 2. Decompose your problem** and sequence diagram in single Data/event Flows, from client side and server side.
- 3. Identify the single Data/Event Flow**, as those that start from a certain event (periodic or provoked from other messages), and that finish with: sending of data in the storage, change status, send an event, provide a message into a dashboard, send an email, etc.
- 4. Design the single Data/Event Flows** with a mixt of possible **activities**.
  1. The design can be performed using data flow diagrams.
  2. It can have sequences, switch, serialization, packing, joining, distribution, communication, transformation, search, etc.
5. When the design of Data/Event Flow mechanism is clear the designers can pass to directly sketch the flow in Node-RED which is a visual programming.
- 6. Incrementally improve the Proc.Logic** (IoT App) Node-RED flows by adding nodes needed
- 7. Once obtained the Proc.Logic** (IoT App) Node-RED flows in the correct data model you can send data to the ingestion broker, but also perform many other actions on several services.

# IoT App / Proc.Logic Design, for each Data/Event Flow

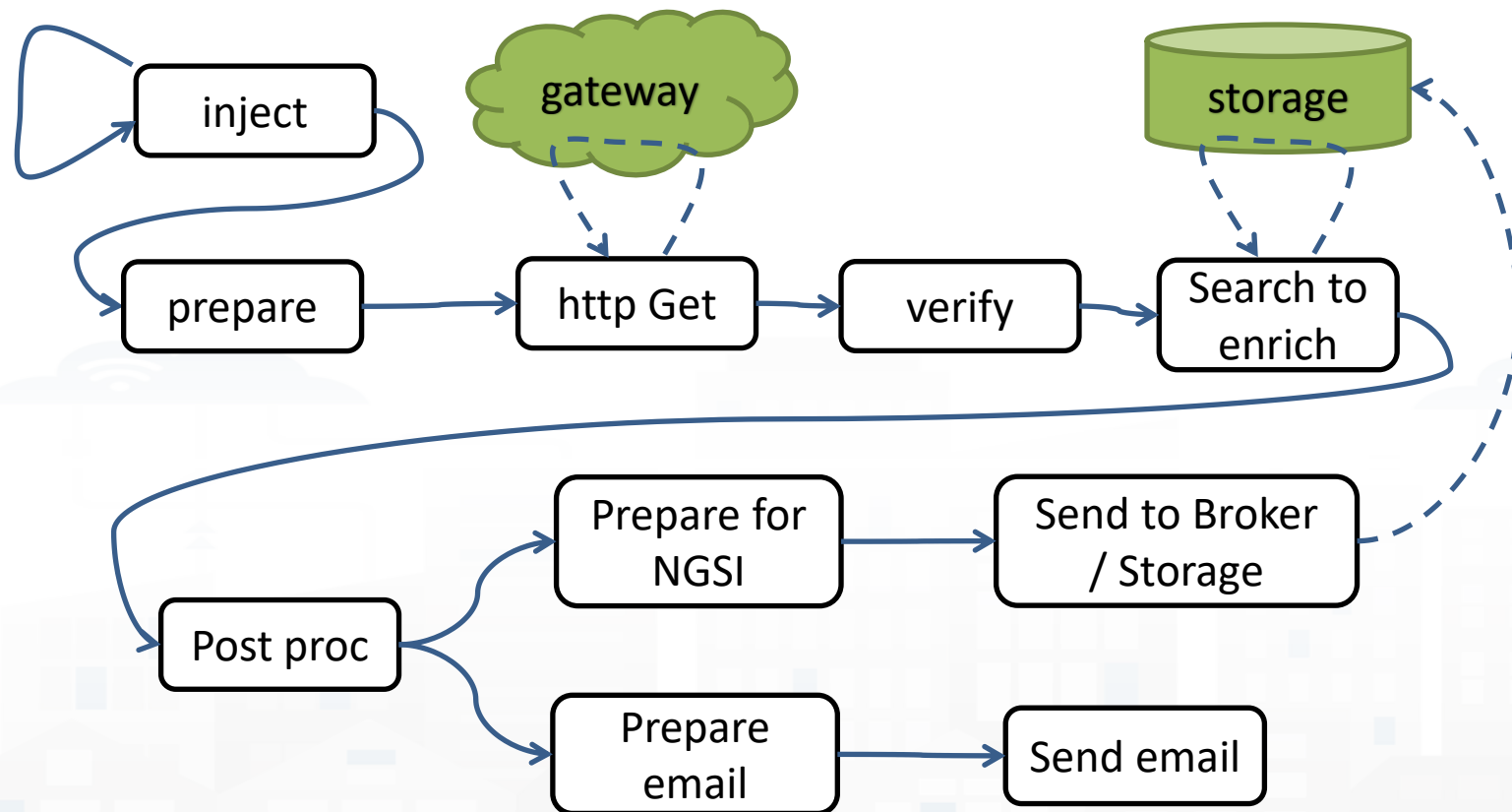

- Periodically activate the flow
- Call a gateway to get data
- Verify the correctness of data
- Enrich the data with other information coming from Cloud data into the storage
- Transform the data in the correct forma
- Send the data into the IoT Broker, and thus send the data in the storage on a specific IoT Device
- Send also a notification via email

TOP

# *Develop:* *Data Processes*

Part 3

Part 5



# How the Dashboards exchange data

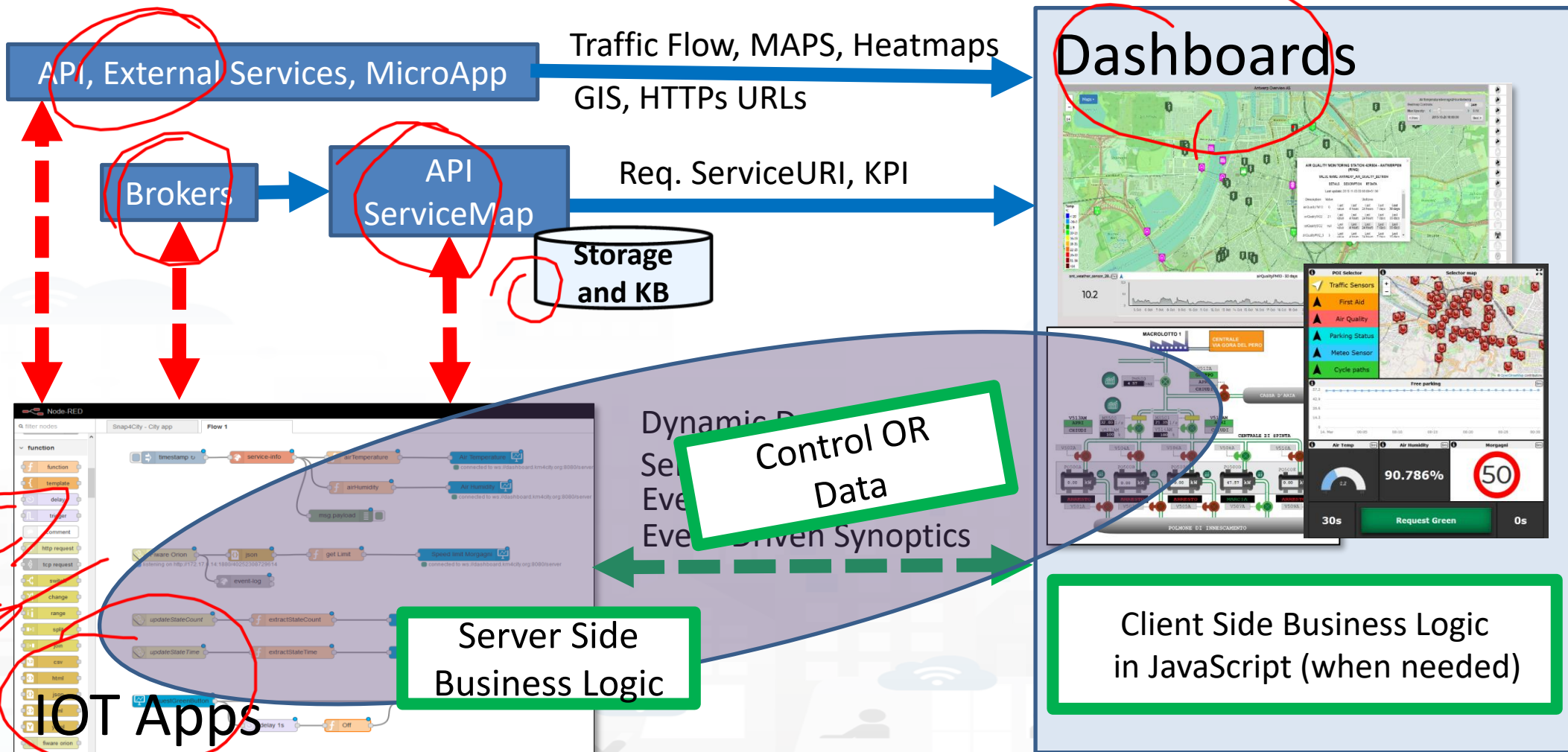

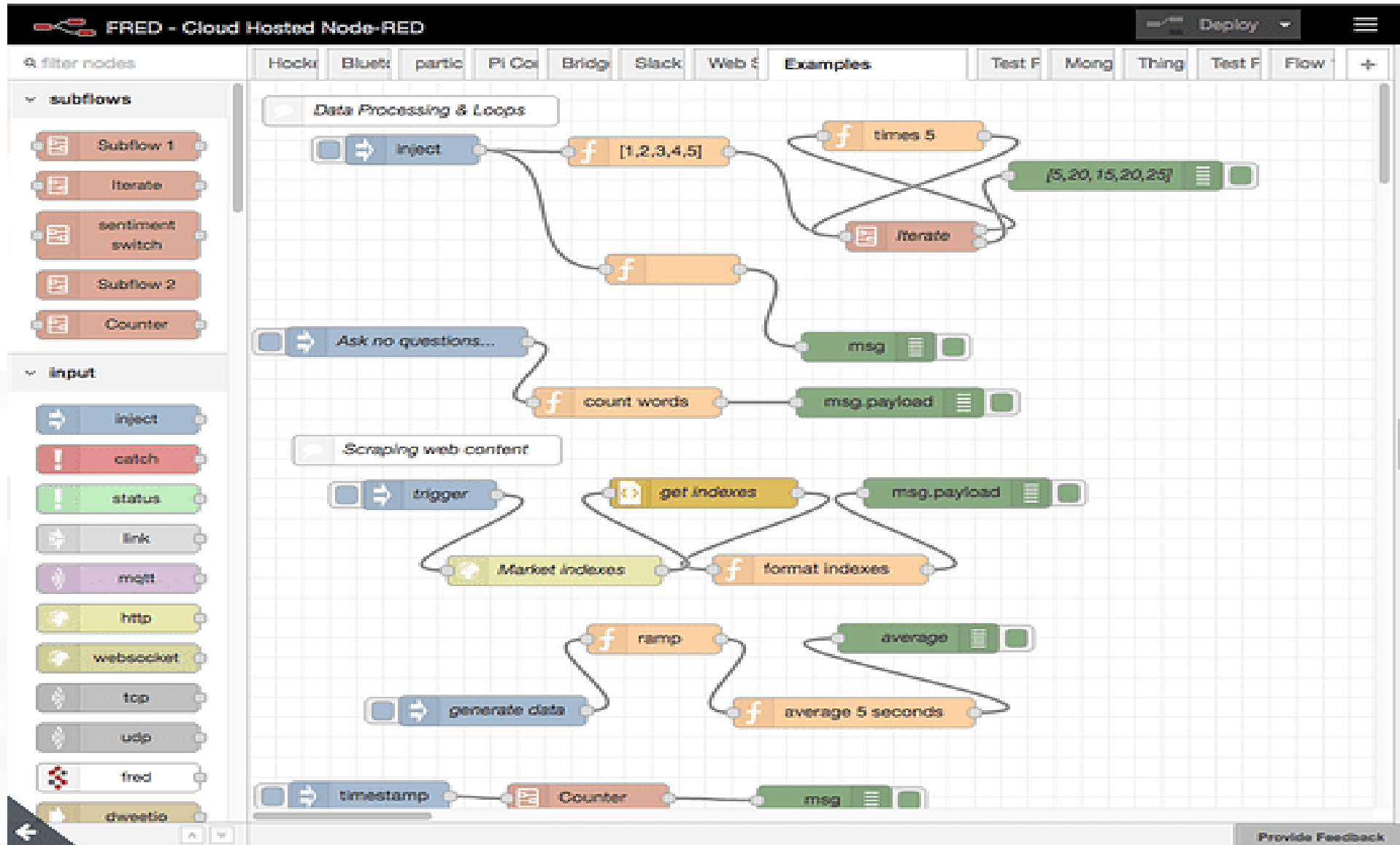

# Proc.Logic (IoT App) Design, for each Data/Event Flow

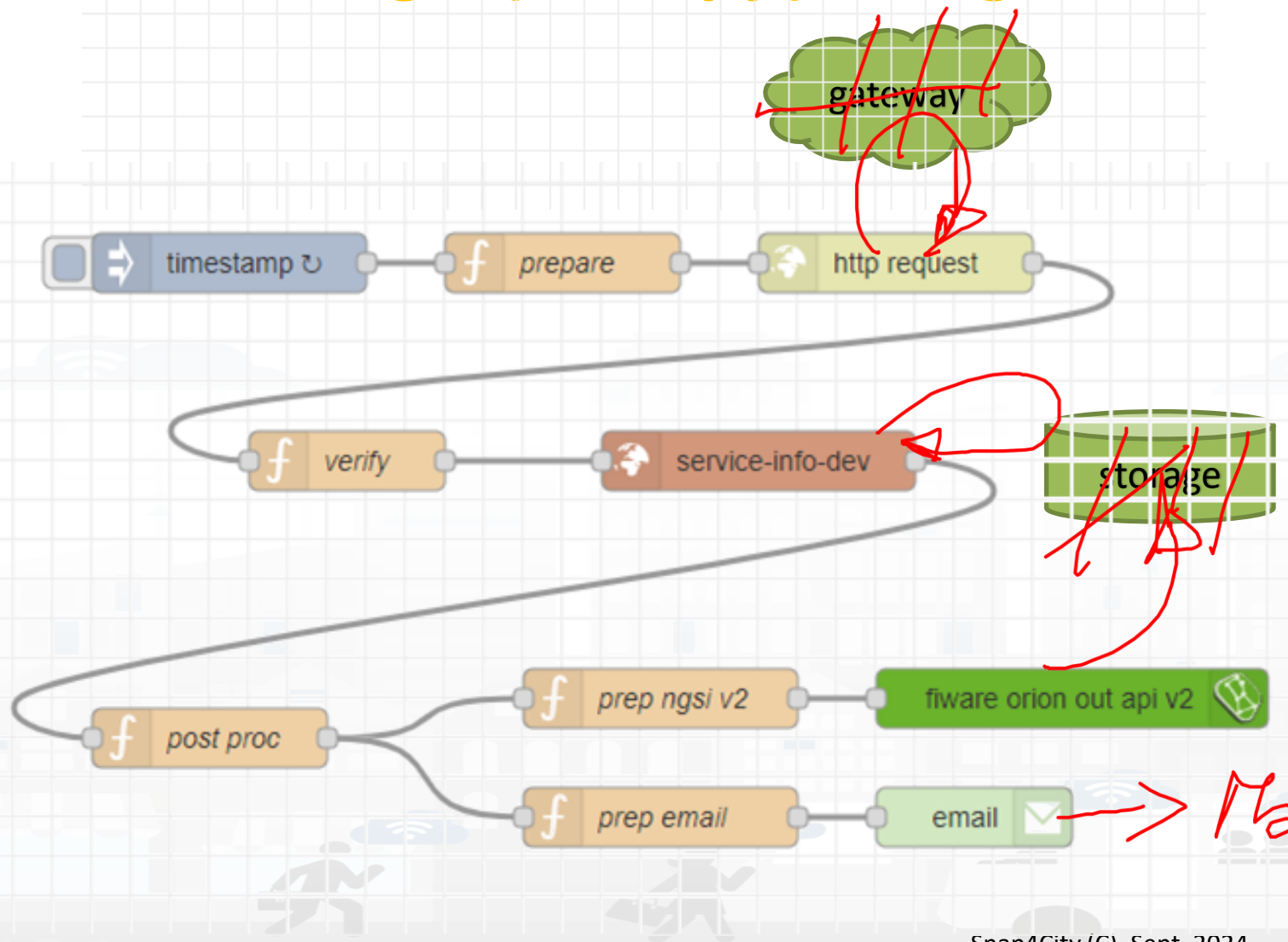

- Periodically activate the flow
- Call a gateway to get data
- Verify the correctness of data
- Enrich the data with other information coming from Cloud data into the storage
- Transform the data in the correct forma
- Send the data into the Broker, and thus send the data in the storage on a specific Entity Instance
- Send also a notification via email

*Only Server*

**Implicit services are not drawn**

# A sample of Data Ingestion

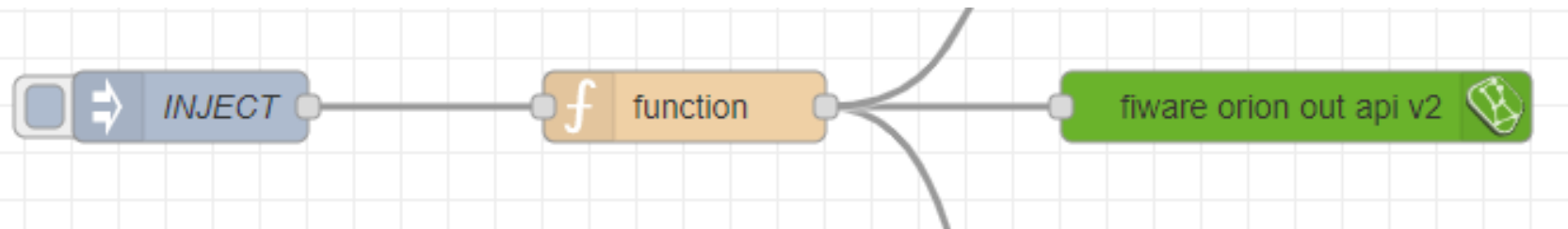

Function, example of NGSI V2 payload:

```
var time_now = new Date().toISOString();
var arandvalue = Math.random()
```

```
msg.payload =
```

```
  {"id":"mydev",
   "type":"mydevSensor",
   "anID":{"type": "integer", "value": "http://www.disit.org/km4city/resource/iot/...../anuser"},
   "VDDValue":{"type":"float","value":arandvalue},
   "dateObserved":{"type":"string","value":time_now}, // it is a time serie
   "latitude":{"type":"float","value":"28.61810"}, // it may move over time
   "longitude":{"type":"float","value":"11.34300"}, // it may move over time
   "status":{"type":"integer","value":34}
  }
```

```
return msg;
```

Posted data on IoT Brokers  
**green nodes** are automatically  
saved into the data Storage



# Read and share Data and Context Data

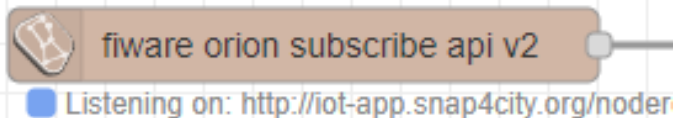

1) Event driven from Broker, read last context data. It is not sure that this change is on Storage

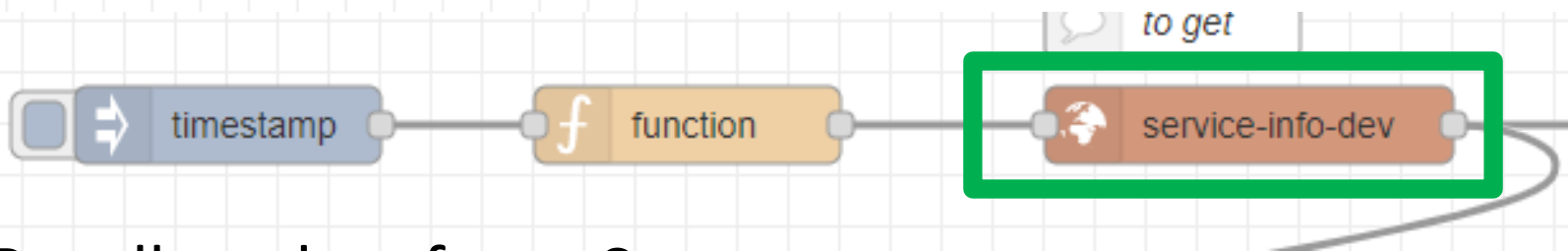



2) Recollect data from Storage

- This node uses the Smart City API
- **Any External Application** can get the same data in authenticated authorized manner via Smart City API
- Smart City API is a better approach instead of producing a file outside or providing data via some local API service created from IoT Application (feasible but not protected)

- Please note that the most important blocks nodes to interact with the platforms are reported in this table to familiarize with the main concepts. ***They are actually families of blocks/nodes*** since many others are present that allow you to perform a very large number of other features.
- YOU DO NOT HAVE TO ACCESS AT THE API all is provided in terms of NODEs/BLOCKS into IoT APP. Everything can be parametrized via JSON passed in input to the nodes.
- Most of the nodes can be also configured once from their user settings but the JSON is primary mode for setting parameters.

# examples

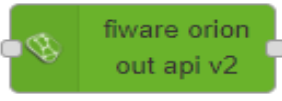
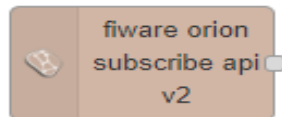
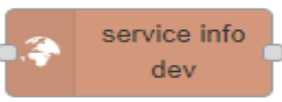
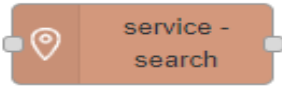
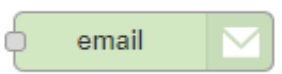
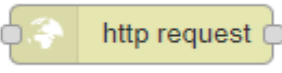
| Node shape                                                                          | Description                                                                                                                                                                                                                                                                                                                                                                                 | Snap4City or standard |
|-------------------------------------------------------------------------------------|---------------------------------------------------------------------------------------------------------------------------------------------------------------------------------------------------------------------------------------------------------------------------------------------------------------------------------------------------------------------------------------------|-----------------------|
|    | To generate injection messages into a flow, scheduled or on manual demand by click it on left.                                                                                                                                                                                                                                                                                              | standard              |
|    | A java script function, from a JSON input to one or more JSON outputs, which can be produced by setting it.                                                                                                                                                                                                                                                                                 | standard              |
|    | To send an Entity Message of an Entity Instance into the storage. The Entity Instance has to be registered on Entity Directory (IoT Directory) and you have to be the owner or to be delegated in READ-WRITE to send messages to it. The node represents the broker, so that the same node can be used to send any Entity Message you need.                                                 | Snap4city             |
|    | To subscribe the Processing Logic (IoT App) to receive event-driven notifications related to Entity Instances changes. The node is substantially a listener connected to an Orion Broker. You can subscribe to many Entities and then to get all of them from the output of the listener. The new version will go to provide an input port to send at this listener multiple subscriptions. | Snap4city             |
|   | Query call to Smart City API to get any information about a SURI, ServiceURI. There are many other Nodes which can be used to pose Smart City API queries in very simple manner and recover vectors of ServiceURIs.                                                                                                                                                                         | Snap4city             |
|  | To perform queries on the storage to obtain a list of ServiceURI. The nodes of this family can allow you to perform searching queries by filtering for distance, area, subnature/category, values of attributes, time period, etc.                                                                                                                                                          | Snap4city             |
|  | Send email. With other nodes you can send Telegram, SMS, etc.                                                                                                                                                                                                                                                                                                                               | standard              |
|  | To send a REST CALL (get, post, etc.). Please USE THIS NODE ONLY for the access at external API and not to access at the Snap4City API for which a lot of MicroServices are accessible as NODEs/Blocks in the Processing Logic and they are simpler to be used and ready to use.                                                                                                            | standard              |

|  |                                                                                                                                                                                                                                                                                                                                                                                                                                                       |                  |
|--|-------------------------------------------------------------------------------------------------------------------------------------------------------------------------------------------------------------------------------------------------------------------------------------------------------------------------------------------------------------------------------------------------------------------------------------------------------|------------------|
|  | <p>A block which is printing on <b>debug</b> view the data JSON passed in its input. Please note that the node can be tuned to provide only <u>msg.payload</u> or the full JSON message, change configuration of the node.</p>                                                                                                                                                                                                                        | <p>standard</p>  |
|  | <p>To <b>create an Entity Instance</b> (device instance) from a model prepared on Entity Directory (IoT Directory).</p>                                                                                                                                                                                                                                                                                                                               | <p>Snap4city</p> |
|  | <p>To <b>change the ownership</b> of an Entity Instance (IoT Device).</p>                                                                                                                                                                                                                                                                                                                                                                             | <p>Snap4city</p> |
|  | <p>To <b>delegate a certain Entity Instance</b> (IoT Device) to some other user for which you <u>have to know</u> the Nickname. Delegations can be: <u>Read access</u>, <u>Read write</u>, Modify (to modify the Entity Instance structure).</p>                                                                                                                                                                                                      | <p>Snap4city</p> |
|  | <p>To <b>show something on Snap4City dashboard</b> with a single content widget (one of the simplest widgets). A large set of dashboard nodes/widgets to send and retrieve data to/from dashboards are provided. This specific Nodes allows to send on dashboard HTML formatted messages with some limitations. Full HTTP widget is also accessible.<br/>See in the following section for the Full list of Nodes for Snap4City Dashboard Widgets.</p> | <p>Snap4city</p> |
|  | <p><b>MQTT broker listener</b>, to receive messages from the Broker. Another similar node can be used to send MQTT messages to the MQTT broker. This node allows to perform a subscription to a topic of the MQTT broker.</p>                                                                                                                                                                                                                         | <p>standard</p>  |
|  | <p><b>DATA ANALYTICS</b><br/>Request performed on a Container including a Python data analytics, which is loaded into the node and the container is created at the first Deploy of the Processing Logic. Similar Approach is performed for RStudio Data Analytics.</p>                                                                                                                                                                                | <p>Snap4city</p> |
|  | <p><b>SPLIT:</b> This block takes in input a buffer, or an array, or an object and split it on a set of messages in output, for each line in the buffer, each element of the array, each element in the object, respectively.</p>                                                                                                                                                                                                                     | <p>standard</p>  |
|  | <p><b>JOIN:</b> This block takes in input a set of messages and join/merge them into a single message (string, buffer, <u>array</u> or object, etc.), on the basis of specific criteria.</p>                                                                                                                                                                                                                                                          | <p>standard</p>  |

# The Proc.Logic (IoT App) microservices

Actually, there are more than 180 nodes/blocks in the Snap4City libraries on Processing Logic (IoT App) which can really facilitate your life and save you time in producing Smart Applications for composition of the following microservices and using those that you can install from internet, thousands of functionalities:

- **Data ingestion:** more than 100 protocols IOT and Industry 4.0, web Scraping, external services, any protocol database, etc.
- **Data access:** save/retrieve data, query search on expert system, georeverse solution, search on expert system Km4City ontology, call to Smart City API, etc.
- **Data Transformation/transcoding:** binary, hexadecimal, XML, JSON, String, any format
- **Integration:** CKAN, Web Scraping, FTP, Copernicus satellite, Twitter Vigilance, Workflow OpenMaint, Digital Twin BIM Server, any external service REST Call, etc.
- **Manipulation of complex data:** heatmaps, scenarios, typical time trend, multi series, calendar, maps, etc.
- **Access to Smart City Entities and exploitation of Smart City Services:** transport, parking, POI, KPI, personal data, scenarios, etc.
- **Data Analytic:** managing Python native, calling and scheduling Python/Rstudio containers as snap4city microservices (predictions, anomaly detection, statistics, etc.)
- **User interaction on Dashboard:** get data and message from the user interface, providing messages to the user (form, buttons, switches, animations, selector, maps, etc. ), send data to special graphical widgets: D3, Highcharts, etc.
- **Custom Widgets:** SVG, synoptics, animations, dynamic pins on maps, etc
- **Event management:** Telegram, Twitter, Facebook, SMS, WhatsApp, CAP, etc.
- **Special tools as:** routing, georeverse, Twitter Vigilance and sentiment analysis, etc.
- **Hardware Specific Devices:** Raspberry Pi, Android, Philips, video wall management, etc.
- **Etc. etc.**

# Technical Architecture

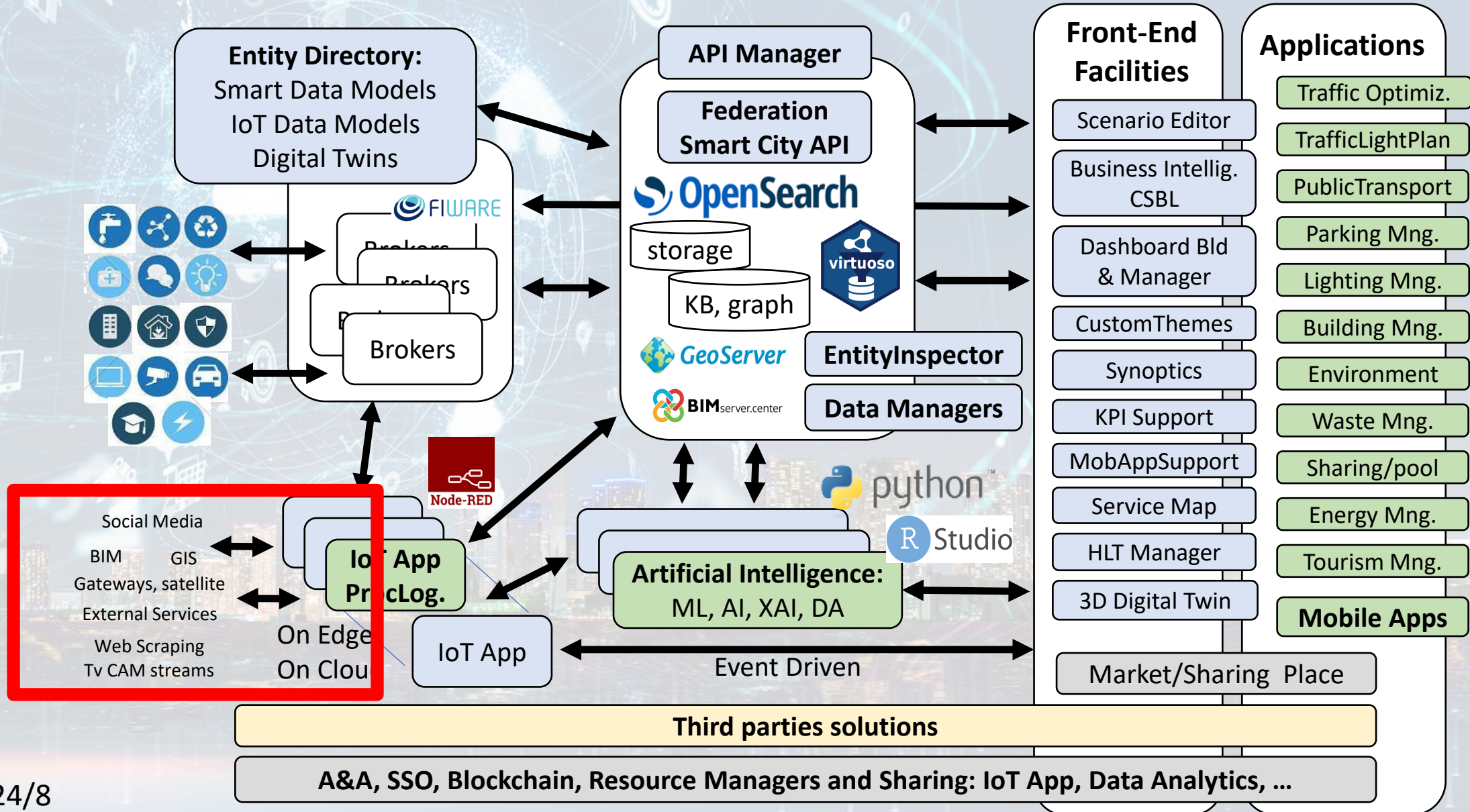

# Some patterns

- 1) Hello world of node-red, the inject may provide a string to the debug.

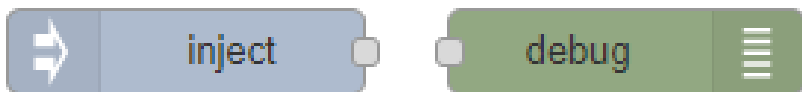

- 2) Hello world of node-red at two steps, the inject provides a push while a JSON is created into the function as *msg.payload = {.....}* and sent/shown to/by the debug.

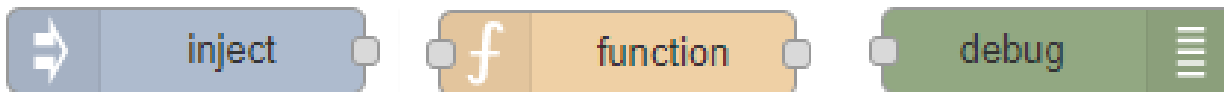

- 3) Event data reception from an MQTT broker, transformation and send it to the storage pushing data into the Orion Broker V2.



- 4) request on inject of a SURJ to the storage to see data on debug.

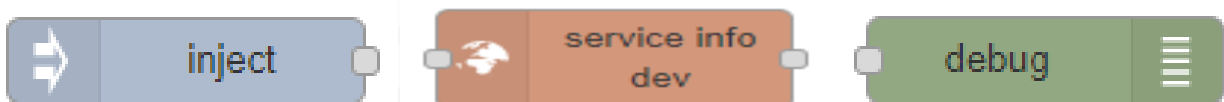

- 1) Preparation of data request on function, query to the storage and see data result on debug.

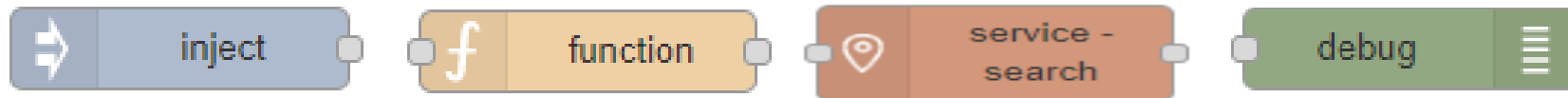

- 2) Event data reception from an MQTT broker, transformation to create an Entity Instance from a known Entity Model, debug to see eventual errors, for example if the device is already present (to avoid production of error, one may verify if the Entity Instance is already present by posing a query on the system):



- 3) Preparation of data parameters on function, request computing Data Analytic, see data result on debug.





## Typical strange patterns that may be not efficient in most cases:

- A. data reception from an MQTT broker, their transformation to create an Entity Instance from a known Entity Model, contextually to create and send an Entity Message into newly created Entity Instance, the debug to see eventual errors. This approach is typically strange since at each new message the Entity Directory is queried to see if the Entity is already be created and if not to create it and then pass the data to register the message. In most cases, it is much better to decouple the activity of creating with respect to that of sending message. In fact, this approach would largely reduce the ingestion rate and probably when the Entities are already created would create un-useful workload on Entity Directory (IoT Directory).

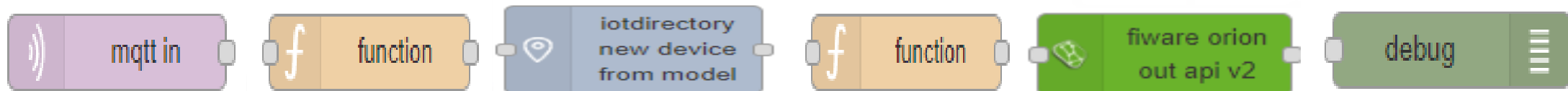

In most cases, it should be done the opposite: try to send the Entity Message, if it fails than create a new Entity Instance by known model, and if successful send again the Entity Message, or just wait for the new message to save it the first.

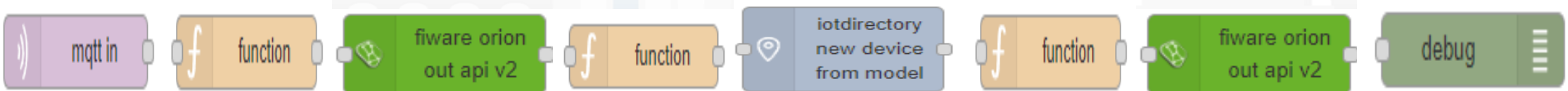

# Sync data changes on Entities from an Event

If I would like to synchronize a device data A with another B by trigger event, I can do it in several manners. The first case would be the simplest. A triggering message arrives from MQTT event or from some NGSI ORION, or from some MyKPI, from dashboard event button, or email or anything, it does not matter. I can use two functions to prepare the message for A device and B device as follow:

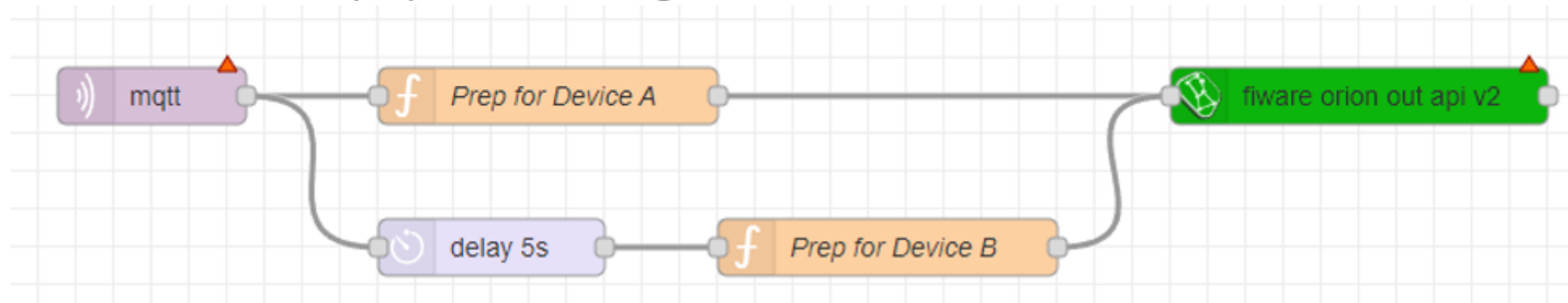

# Subscribe on event from Broker, be careful....

If the event for triggering is from another device/entity changed by some action performed posting a data on Orion Broker V2, you can subscribe with the event on the Orion broker by using a specific Node (do it once otherwise you risk receiving many events). Every time the device / entity receives a message you can take it and generated a new message for a different device and post it on Orion API V2.

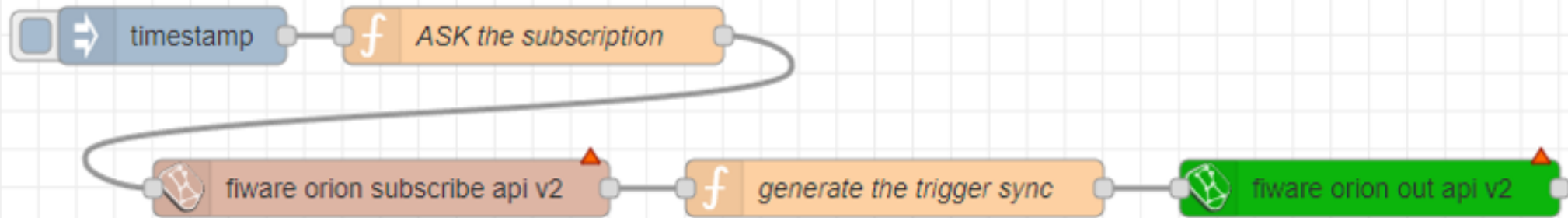

If you need to verify if the new data has been changed, you can read the last value of recipient Device/entity to compare and decide to update or not:

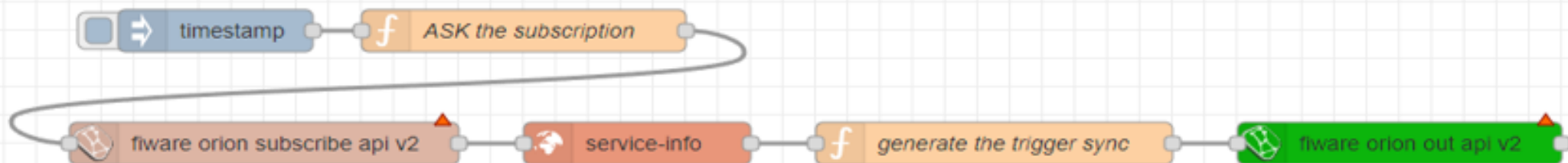

# Delete Devices

## IV.C.1.e- Delete Devices

Recently a node to delete devices has been added. It has to be used veery carefully since to delete data is always a terrible activity in a big data storage.

The delete of a device is allowed only for the Owner of the device and the root administrator of the platform. The device delete can be also performed from the Entity Directory and now with the Delete-Device node can be performed also from Proc. Logic / IoT App.

The classic pattern is as follows, including preparation, a RATE Limitation avoiding to provide more than one delete message every 50 seconds:

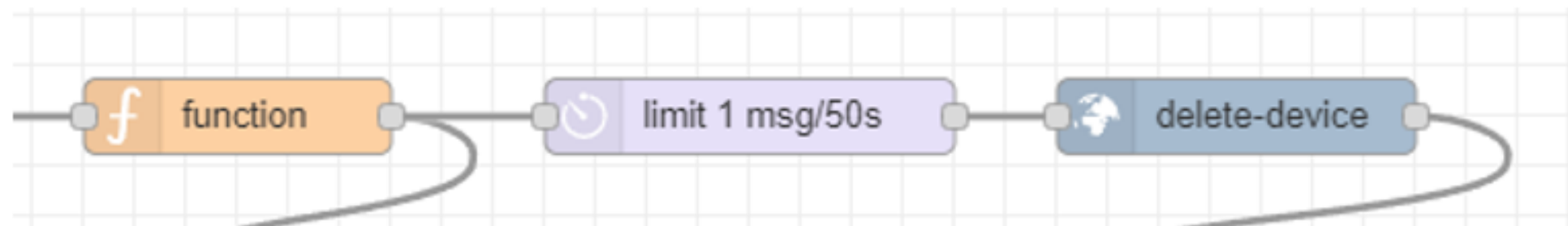

The delete device node needs in input Device ID and Broker ID. All data that you can recover from the Entity Directory.

TOP

# *Proc.Logic / IoT App*

Part 3

# *Development*

Part 5



# Snap4city Data Ingestion Diagram

storage

Manual or automated  
Registration  
of Entities/Devices

**Entity/IoT  
Directory**

registration  
triples

NGSI



**Orion Broker**

IoT Orion Broker

IoT Orion Broker

IoT Orion Broker

IoT Orion Broker

**Brokers**

subscription note

NGSI

Real Time

**Knowledge Base**

Semantic Reasoners

Semantic Reasoners

Semantic Reasoners

SURI Link

**Indexing and Aggregating**  
NIFI, OpenSearch

**Data Managers**

**Data Managers**

**Entity Inspector**



A number of KB  
federated



**Federation**  
Smart City API, ASCAPI

**API Manager**

Cluster of **OpenSearch**  
for storage with in  
front a cluster of  
NIFI

**Platform Automation:**  
IoT Apps, Proc.Logics,  
Python, ...



**R Studio** **Data Analytics: ML, AI, XAI** **python**

**Platform Control and Management**

Massive data flow  
entering

Massive data flow  
exiting

# Proc.Logic / IoT App Development

IOT Discovering

MicroServices collections

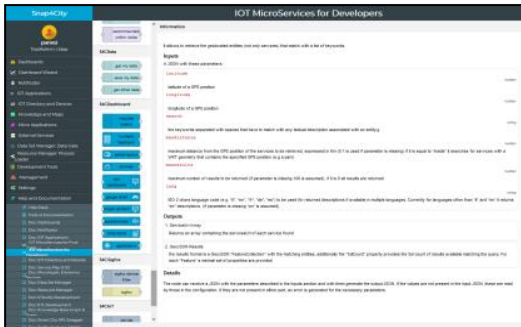

My IoT Applications



IoT App. Editor



Generating IoT App With Dashboard

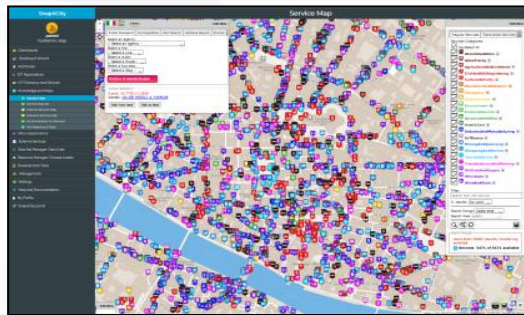

ServiceMap Discovery  
Knowledge Base, Km4City

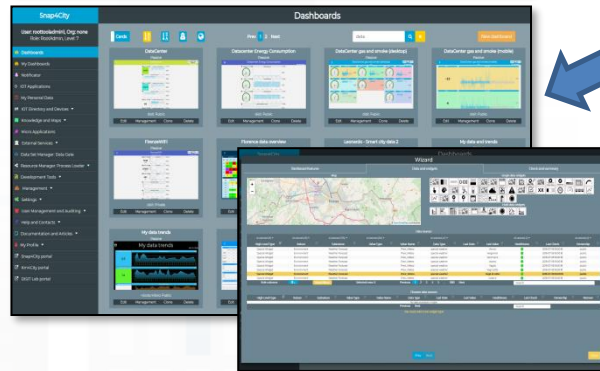

Dashboard Collection,  
Editor and Wizard

Sharing/saving  
reusing IoT App



Resource Manager



Dashboards (Public)



My Snap4City.org



Tour Again

www.snap4solutions.org

Dashboards of My Organization

My Dashboards in My Organization

My Data Dashboard Dev Kibana

Extra Dashboard Widgets

Data Management, HLT

Knowledge and Maps

Processing Logics / IOT App

Processing Logics / IOT App

MicroServices for Proc.Logic/IOT Apps

MicroServices from DataAnalytic

IOT MicroServices for Final Users

IOT MicroServices for Developers

DOC: Processing Logic/IOT App

How to Develop Proc.Logic / IOT Apps

Node-RED

Deploy

filter nodes

Demo 1

Flow 1

Flow 2

Flow 3

debug

- common
  - inject
  - debug
  - complete
  - catch
  - status
  - link in
  - link call
  - link out
  - comment
- function
  - function
  - switch
  - change
  - range
  - template
  - delay
  - trigger
  - exec

Node-RED Proc.Logic / IoT App Editor

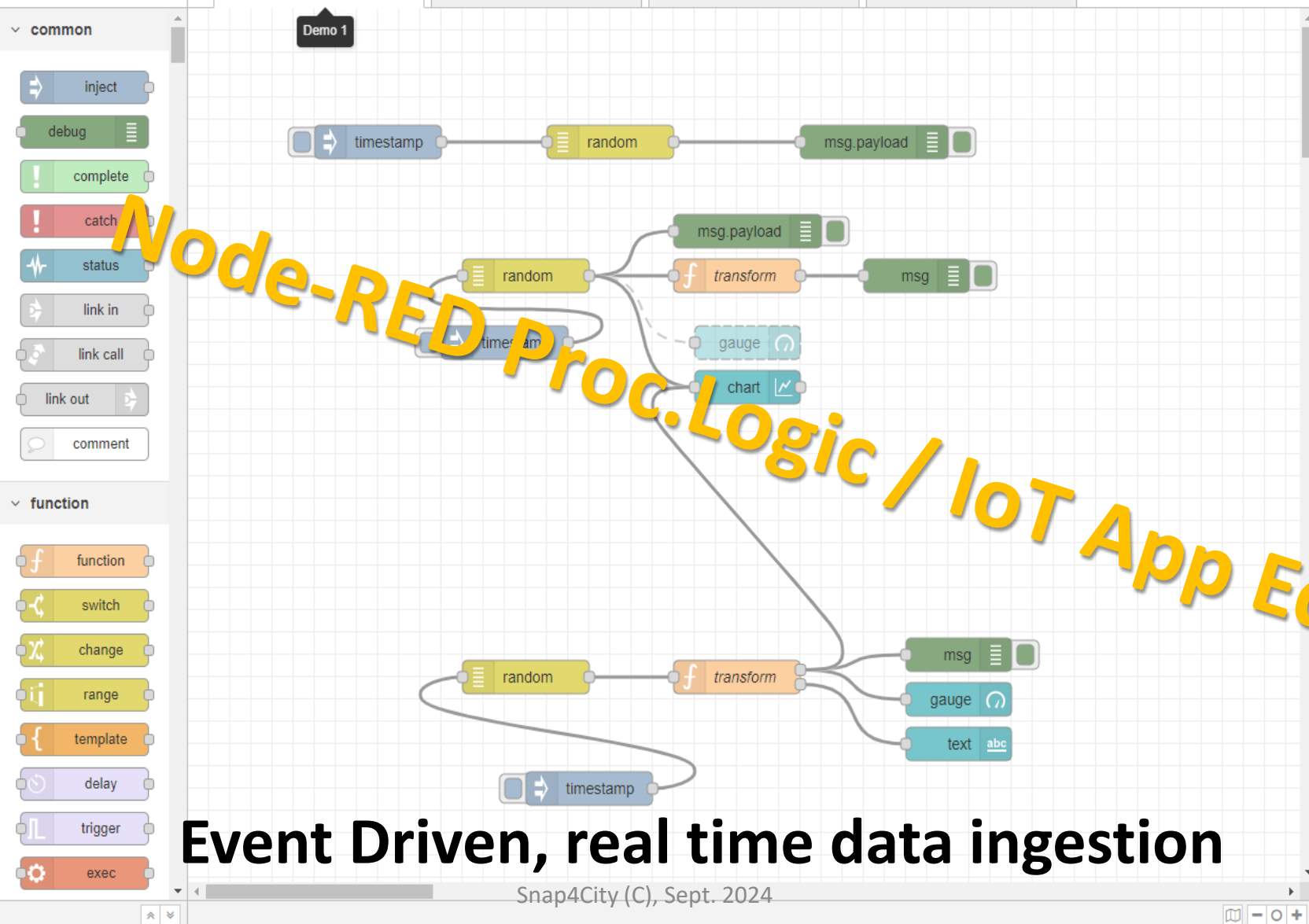

Event Driven, real time data ingestion

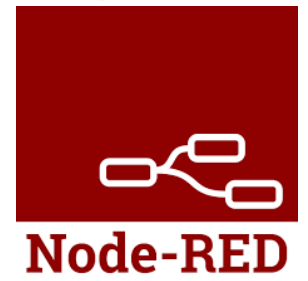



## Areas

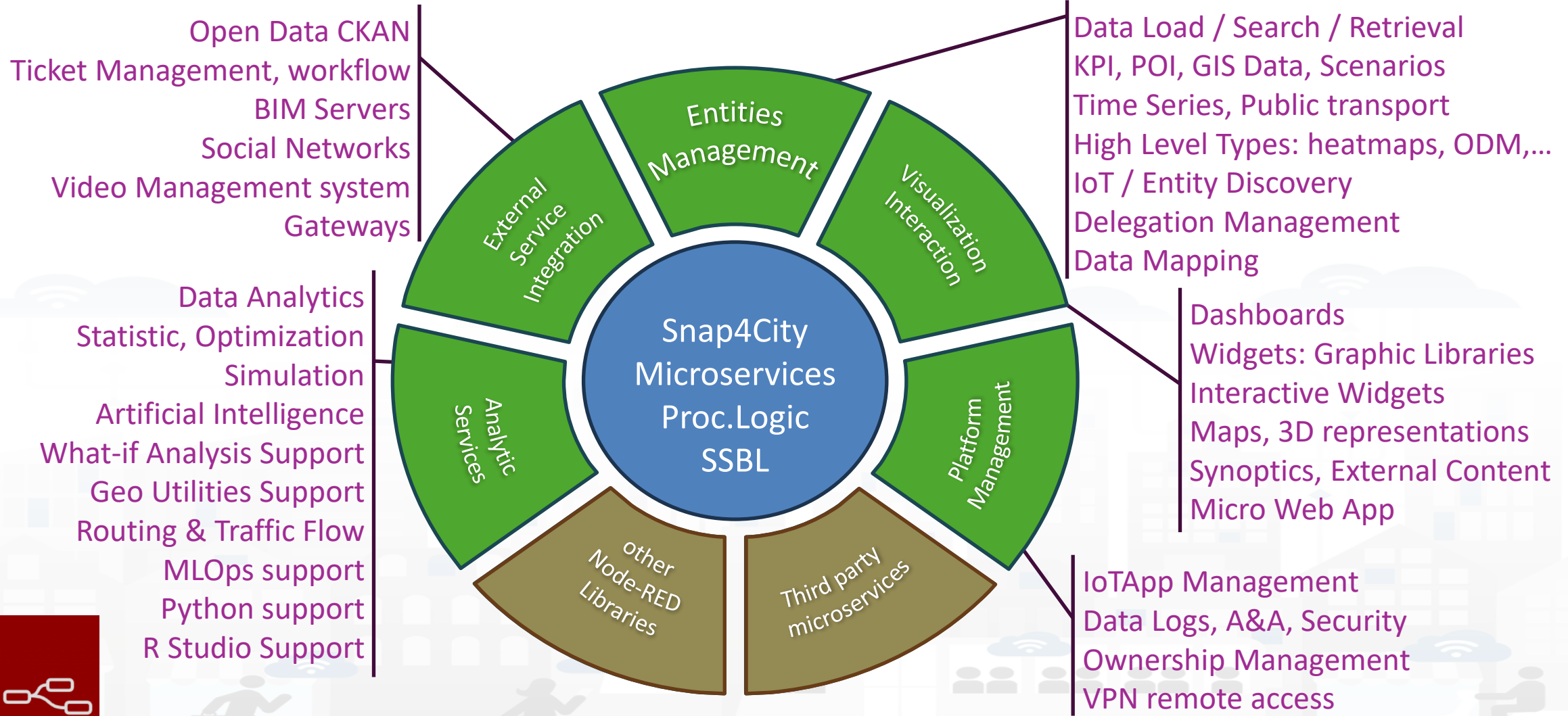

# Basic Node.js Blocks on NodeRed on our Advanced IOT Apps



The screenshot shows the Node-RED block palette with the following categories and blocks:

- common**: inject, debug, complete, catch, status, link in, link out, comment
- function**: function, switch, change, range, template, delay, trigger, exec, zip, md5, soap request, string, xml converter, random, rbe
- network**: mqtt in, mqtt out, http in, http response, http request, websocket in, websocket out, tcp in, tcp out, tcp request, udp in, udp out, amqp in, amqp2 in, stomp in, amqp out, amqp2 out, stomp out
- sequence**: split, join, sort, batch, parser (csv, html, json, xml, yaml, base64, msgpack), storage (file, file in, watch, ftp in, mysql, tail)
- social**: email, twitter in, email, twitter out, advanced (feedparser), NGSi (NGSI Entity, NGSI v2ToLD), lwm2m (lwm2m client in, lwm2m client out), location (turf, worldmap, worldmap in, tracks, convex hull), time (sunrise)
- dashboard**: button, dropdown, switch, slider, numeric, text input, date picker, colour picker, form, text, gauge, chart, audio out, notification, ui control, template

+ on IOT Edge Raspberry

The screenshot shows the Node-RED block palette with the following categories and blocks:

- social**: e mail, twitter, irc, e mail, twitter, irc, google plus, google places, google calendar
- storage**: tail, file, mongodb, file, mongodb
- Raspberry Pi**: rpi gpio, rpi gpio, rpi mouse, rpi keyboard, camerapi takephoto, rpi dht22, imagecapture, ledborg, Sense HAT, Sense HAT
- network**: ping

# Node-RED Basic Blocks

It is provided with a **minimum** set of functionalities (the building blocks/nodes) while other blocks can be easily added loading them from a **large library** made available by the **JS Foundation**.

Despite to its diffusion, for the usage in the context of Smart City it was **not powerful** to cope with the **basic requirements** of the domain.

The classical nodes provided in the standard version can be classified as: input, output, function, social, storage, analysis, advanced, and dashboard.

**Basic Node.js Blocks on NodeRed on our Advanced IOT Apps**

Categories shown: common, network, sequence, social, dashboard, function, input, output, storage, time.

**+ on IOT Edge Raspberry**

Categories shown: social, Raspberry Pi, storage, network.

99

# IoT Applications

- **Data ingestion:** more than 70 protocols IOT and Industry 4.0, web Scraping, external services, any protocol database, etc.
- **Data access:** save/retrieve data, query search on expert system, georeverse solution, search on expert system Km4City ontology, etc.
- **Data Transformation/transcoding:** binary, hexadecimal, XML, JSON, String, any format
- **Integration:** CKAN, Web Scraping, FTP, Copernicus satellite, Twitter Vigilance, Workflow OpenMaint, Digital Twin BIMServer, any external service REST Call, etc.
- **Manipulation of complex data:** heatmaps, scenarios, typical time trend, multi series, calendar, maps, etc.
- **Access to Smart City Entities and exploitation of Smart City Services:** transport, parking, POI, KPI, personal data, scenarios, etc.
- **Data Analytic:** managing Python native, calling and scheduling Python/Rstudio containers as snap4city microservices (predictions, anomaly detection, statistics, etc.)
- **User interaction on Dashboard:** get data and message from the user interface, providing messages to the user (form, buttons, switches, animations, selector, maps, etc. )
- **Custom Widgets:** SVG, synoptics, animations, dynamic pins on maps, etc
- **Event management:** Telegram, Twitter, Facebook, SMS, WhatsApp, CAP, etc.
- **Hardware Specific Devices:** Raspberry Pi, Android, Philips, video wall management, etc.



# 2024 collection

## Two Snap4City Libraries



> common

> function

> network

> input

> output

> sequence

> parser

> storage

> social

> advanced

> Advanced FTP

> location

> NGSi

> Iwm2m

> S4C SearchDev

> S4C Utility

> S4C Mapping

> S4C Management

> S4C DataAnalytic

> S4C BigData

> S4C IoTApp

> S4C OpenMaint

> S4C IoT

> S4C Whatif

> S4C Search

> S4C Data

> S4C KPiData

> S4C Dashboard

> S4C Sigfox

> S4C LogDev

> S4C View

> S4C Social

> dashboard

> time

**S4C SearchDev**

- service search
- service search near gps position
- service search near service
- service search within gps area
- service search within wkt area
- service search within stored wkt area
- service search by municipality
- service search by queryid
- full text search dev
- full text search within wkt area

**S4C Utility**

- full text search within gps area
- full text search near gps position
- full text search exp
- event search dev
- event search exp
- event search within wkt area
- event search within gps area
- event search near gps position
- address search near gps position
- geometry search near gps position
- address poi search by text

**S4C Mapping**

- address poi search by text exp
- address poi search by text near gps position
- bus routes search
- bus routes search near gps position
- bus routes search within gps area
- bus routes search within wkt area
- bus routes

**S4C DataAnalytic**

- point within polygon
- routing
- heatmap picker
- coordinates to address
- service info
- edge-tunnel-to-cloud
- service info mapped
- mapping
- set mapping

**S4C Management**

- get job detail
- get triggers of job
- get job group names
- get trigger group names
- get paused trigger groups
- get job fire times
- get system status
- trigger job
- pause all
- pause trigger
- pause triggers
- resume all
- resume job
- resume jobs
- resume trigger
- resume triggers

**S4C IoTApp**

- notifier history events
- descriptive statistics
- trend plot
- time series predictions
- machine learning predictions
- anomaly detection
- plumber data analytic
- python data analytic
- datagate search
- datagate create
- portia crawler
- iotapp restart
- iotapp upgrade
- ownership

**S4C Search**

- event search within polygon
- event search along path
- event search usr
- address search near marker
- geometry search near marker
- address poi search by text usr
- address poi search by text near marker
- address poi search by text within circle
- address poi search by text within polygon
- value type search along path

**S4C Data**

- tpl routes by agency
- tpl routes by line
- tpl stops by route
- tpl stop timeline
- recommendatio within circle
- value type search near marker
- value type search within circle
- value type search within polygon
- value type search along path
- get my data
- get my delegator
- get my delegated
- get my activity

<https://flows.nodered.org/search?term=snap4city>



User: roottooladmin1, Org: DISIT  
Role: RootAdmin, Level: 7



Prev 1 2 3 ... 9 Next

Filter

- Dashboards
- My Dashboards
- Notificator
- IOT Applications
- My Personal Data
- IOT Directory and Devices
- Knowledge and Maps
- Micro Applications
- External Services
- Data Set Manager: Data Gate
- Resource Manager: Process Loader
- Development Tools
- Management
- Settings
- User Management and Auditing
- Help and Contacts
- Documentation and Articles
- My Profile
- Snap4City portal
- Km4City portal
- DISIT Lab portal

● 2018-09-14T04:44

IOT Edge App

owner: badii

● 2018-09-21T03:19

IOT Edge App

owner: panesi

● 2018-10-19T16:07

IOT Edge App

owner: pb3

● 2018-10-19T17:17

IOT Edge App

owner: pb3

● 2018-10-22T11:57

IOT Edge App

owner: semolarudy

● application

IOT Application

owner: tester5

● Bib APP

IOT Application

owner: semolarudy

● ChargingStations

IOT Application

owner: comunedashres

● Deprecated - SiIMobilityControlRoom

IOT Application

owner: badii

● SamsungGalaxyS4BarCode

IOT Edge App

owner: badii

● esercitazione

IOT Application

owner: tester2

● lot-App

IOT Application

owner: tester14

# Resource Manager: public and sharing

## Snap4City

User: rootooladmin1, Org: DISIT  
Role: RootAdmin, Level: 7

- Dashboards
- My Dashboards
- Notifier
- IOT Applications
- My Personal Data
- IOT Directory and Devices
- Knowledge and Maps
- Micro Applications
- External Services
- Data Set Manager: Data Gate
- Resource Manager: Process Loader
- View Resources**
- Managing Resources
- MicroServices for IOT Applications
- Process Models
- Processes in Execution
- Process execution Archive
- Development Tools
- Management
- Settings
- User Management and Auditing
- Help and Contacts
- Documentation and Articles
- My Profile
- Snap4City portal

## View Resources

Pages: Prev 1 2 3 ... 12 Next

dev

Reset Username Nature Sub\_nature License Resource\_type Format

- IoTApp (118)
- ETL (53)
- MicroService (8)
- AMMA (4)
- R (3)
- DevDash (2)
- IoTBlocks (2)

### Florence\_Pharmacies\_CSV.zip

developer1: Public  
Username: developer1  
Resource type: ETL  
Nature: geolocated  
Description: Florence Pharmacies o...  
★★★★★  
View Edit Unpublish Owner

### AMMA Tool

developer1: Private  
Username: developer1  
Resource type: AMMA  
Nature: ToBeDefined  
Description: AMMA snap4city dash...  
★★★★★  
View Edit Publish Owner

### Dev Dashboard

snap4city: Private  
Username: snap4city  
Resource type: DevDash  
Nature: data category (ie: geolocat...  
Description: Snap4city Developer D...  
★★★★★  
View Edit Publish Owner

### node-red-contrib-snap4city-developer.rar

snap4city: Private  
Username: snap4city  
Resource type: IoTBlocks  
Nature: data category (ie: geolocat...  
Description: Snap4city NodeRed Li...  
★★★★★  
View Edit Publish Owner

### PaoloApplication.json

developer1: Private  
Username: developer1  
Resource type: IoTApp  
Nature: data category (ie: geolocat...  
Description: NodeRed Flow Shared ...  
★★★★★  
View Edit Publish Owner

### AMMADashSnap4City-30minview-v2-152...

developer1: Private  
Username: developer1  
Resource type: AMMA  
Nature: ToBeDefined  
Description: AMMA snap4city dash...  
★★★★★  
View Edit Publish Owner

### Developer Dashboard New-1526308876256

developer1: Private  
Username: developer1  
Resource type: DevDash  
Nature: ToBeDefined  
Description: Developer Dashboard ...  
★★★★★  
View Edit Publish Owner

### ResDash Docker-1526308998809

developer1: Private  
Username: developer1  
Resource type: ResDash  
Nature: ToBeDefined  
Description: Resource Dashboard: ...  
★★★★★  
View Edit Publish Owner

72



TOP

# search vs services, the **ServiceURI**

The screenshot shows two navigation menus from a web application. The left menu is titled "Entity Directory and Devices" and contains the following items:

- My IOT Sensors and Actuators
- IOT Sensors and Actuators
- Entity Instances, IoT Devices
- IOT Brokers
- FIWARE Smart Data Models
- Entity Models/IoT Devices
- IOT Devices Bulk Registration
- Doc: IOT Directory and Devices

The right menu is titled "Data Management, HLT" and contains the following items:

- Data Inspector
- MyKPI, MyData, MyPOI
- My Groups of Entities
- View/Set MyPOI on Tuscany
- Data Table Loader (Excel)
- POI Loader (Excel)
- Harvest Satellite Copernicus Dat...
- File Manager
- HeatMap Manager



- **For:**  
IOT Devices,  
Sensors, Sensor  
mobile,  
Actuators,  
Virtual Sensors,  
etc.
- Accessible as
  - ServiceURI
  - **Device URI**

The screenshot shows the Snap4City IoT Directory interface. On the left is a navigation sidebar with the 'IOT Devices' section selected. The main area displays a table of IoT devices. The device 'AdminDevice001' is highlighted, and its details are shown below the table. A green arrow points from the 'Device URI' field in the details to the 'Device URI' field in the table below.

| Device Identifier             | IOT Broker                | Device Type       | Model                | Ownership    | Status | Edit | Delete | Location | View |
|-------------------------------|---------------------------|-------------------|----------------------|--------------|--------|------|--------|----------|------|
| 15EP22T2AA1S000022            | orionFirenze-UNIFI        | ChargingStation   | ChargingStationModel | PUBLIC       | active | EDIT | DELETE |          | VIEW |
| AccessPoint1_FamilaSuperstore | orionLonatoDelGarda-UNIFI | AccessPointSensor | AccessPointLonato    | DELEGATED    | active | EDIT | DELETE |          | VIEW |
| AccessPoint2_ITIS             | orionLonatoDelGarda-UNIFI | AccessPointSensor | AccessPointLonato    | DELEGATED    | active | EDIT | DELETE |          | VIEW |
| AccessPoint3_Palaspport       | orionLonatoDelGarda-UNIFI | AccessPointSensor | AccessPointLonato    | DELEGATED    | active | EDIT | DELETE |          | VIEW |
| adminDev1                     | orionUNIFI                | Ambiental         |                      | MYOWNPUBLIC  | active | EDIT | DELETE |          | VIEW |
| AdminDevice001                | orionUNIFI                | Ambiental         |                      | MYOWNPRIVATE | active | EDIT | DELETE |          | VIEW |

Details for AdminDevice001:

- Broker URI: https://broker1.snap4city.org
- Kind: sensor
- Device Type: Ambiental
- Protocol: ngsi
- Model:
- Longitude: 9.228193
- Device Uri: http://www.disit.org/km4city/resource/iot/orionUNIFI/AdminDevice001
- Organization: DISIT
- PAYLOAD NGSI v1: K1: b7c4c115-f25c-4cb6-95eb-e4b363222bef
- PAYLOAD NGSI v2: K2: 441ffb6c-dc8a-4fc9-a415-7f6564d656f5
- Created on: 2018-05-24 21:54:03

Device Uri: <http://www.disit.org/km4city/resource/iot/orionUNIFI/AdminDevice001>

# Understanding / Testing an Entity/ IoT Device

|                                                                                                                                                               |                |                     |           |                        |                     |                                         |             |                                    |  |             |
|---------------------------------------------------------------------------------------------------------------------------------------------------------------|----------------|---------------------|-----------|------------------------|---------------------|-----------------------------------------|-------------|------------------------------------|--|-------------|
|                                                                                                                                                               | AdminDevice001 | orionUNIFI          | Ambiental |                        | <b>MYOWNPRIVATE</b> | active                                  | <b>EDIT</b> | <b>DELETE</b>                      |  | <b>VIEW</b> |
| Broker URI: <a href="https://broker1.snap4city.org">https://broker1.snap4city.org</a>                                                                         |                | Kind: sensor        |           | Broker Port: 8080      |                     | Visibility: MyOwnPrivate                |             |                                    |  |             |
| Device Type: Ambiental                                                                                                                                        |                | Protocol: ngsi      |           | Format: json           |                     | MAC:                                    |             |                                    |  |             |
| Model:                                                                                                                                                        |                | Longitude: 9.228193 |           | Producer: Raspberry PI |                     | Latitude: 45.499369                     |             |                                    |  |             |
| Device Uri: <a href="http://www.disit.org/km4city/source/iot/orionUNIFI/AdminDevice001">http://www.disit.org/km4city/source/iot/orionUNIFI/AdminDevice001</a> |                | Organization: DISIT |           |                        |                     |                                         |             | <b>VIEW IN SERVICE MAP</b>         |  |             |
| <b>PAYLOAD NGSI v1</b>                                                                                                                                        |                |                     |           |                        |                     |                                         |             | <b>VIEW DATA IN AdminDevice001</b> |  |             |
| K1: b7c4115-f25c-4cb6-95eb-e4b363222bef                                                                                                                       |                |                     |           |                        |                     |                                         |             |                                    |  |             |
| Created: 2018-05-24 21:54:03                                                                                                                                  |                |                     |           |                        |                     |                                         |             |                                    |  |             |
|                                                                                                                                                               |                |                     |           |                        |                     | <b>PAYLOAD NGSI v2</b>                  |             |                                    |  |             |
|                                                                                                                                                               |                |                     |           |                        |                     | K2: 41ffb6c-dc8a-4fc9-a415-7f6564d656f5 |             |                                    |  |             |



See Payload NGSI V1 in JSON directly from the Broker, Last message of the broker

The Broker

See Payload NGSI V2 in JSON directly from the Broker, Last message of the broker

See IoT Device on ServiceMap

Create a Message to be sent at the IoT broker regarding this device.

# New Data Inspector/Wizard

New Wizard

Data Inspector BETA OS

The interface includes a map of Florence, a dashboard with various widgets, a table of data sources, and a time-series graph. A large red watermark 'New Wizard' is overlaid on the map area.

| Level | Type       | Nature             | Subnature  | Device            | Model | Broker             | Value Name          | Value Type | Data Type | Value Unit | Last Date           | Last Value | Healthiness | Last Check         | Ownership |
|-------|------------|--------------------|------------|-------------------|-------|--------------------|---------------------|------------|-----------|------------|---------------------|------------|-------------|--------------------|-----------|
| DT    | EM Devi... | Environment        | Weather    | DIDA1             |       | Santa Verdiana ... | Mio sensore         | webpage    |           |            | 2021-11-23 13:44... |            | ●           | 2023-07-18 16:0... | public    |
| DT    | EM Devi... | TransferService... | SensorSite | METRO11           |       | Altair-soda        | Altair Valve State  | webpage    |           |            | 2021-06-05 00:00... |            | ●           | 2024-01-10 01:3... | public    |
| DT    | EM Devi... | IndustryAndMa...   | Computer   | AltairStatoPom... |       | Altair-soda        | Altair Pump St...   | webpage    |           |            | 2021-05-20 13:51... |            | ●           | 2024-01-10 01:3... | public    |
| DT    | EM Devi... | Environment        | Air        | IBIMET_SMART...   |       | Altair-soda        | Altair pump 43...   | webpage    |           |            | 2021-06-07 17:3...  |            | ●           | 2024-01-10 01:3... | public    |
| DT    | EM Devi... | Environment        | Air        | ARPAT_QA_FI...    |       | Altair-soda        | Altair valve 541    | webpage    |           |            | 2021-06-07 17:3...  |            | ●           | 2024-01-10 01:3... | public    |
| DT    | EM Devi... | TransferService... | SensorSite | METRO514          |       | Altair-soda        | Altair Pump 4321    | webpage    |           |            | 2021-06-07 00:00... |            | ●           | 2024-01-10 01:3... | public    |
| DT    | EM Devi... | TransferService... | SensorSite | SI052032F5990...  |       | Altair-soda        | Altair Stock sta... | webpage    |           |            | 2021-06-07 00:00... |            | ●           | 2024-01-10 01:3... | public    |
| DT    | EM Devi... | TransferService... | SensorSite | METRO831          |       | Altair-soda        | Altair Pump 92...   | webpage    |           |            | 2021-06-07 00:00... |            | ●           | 2024-01-10 01:3... | public    |

- Filtering/Searching for individual fields (even for some fields not displayed as geographic coordinates)
- Geographic Filtering
- Text Search on all fields
- Menu for choosing the fields to display in the table
- View on Map(via PREVIEW)
- Data and Trend visualization
- Opening Digital Twin
- Pass to Synoptic mode
- Select the graph representation



**Snap4City**

User: roottooladmini, Org: DISIT  
Role: RootAdmin, Level: 7

[LOGOUT](#)

- My Snap4City.org
- Dashboards
- My Dashboards in All Org.
- Dashboards of My Organization
- My Dashboards in My Organization
- Notificator
- Data Inspector**
- My Data, KPI, POI
- IOT Applications
- IOT Directory and Devices
- Knowledge and Maps
- Micro Applications
- External Services
- Data Set Manager: Data Gate
- Resource Manager: Process Loader
- Development Tools
- Management
- Settings
- User Management and Auditing
- Help and Contacts
- Documentation and Articles

**Data Inspector**

Single data widgets  
Multi data widgets  
Map Controls: FilterMap, GPSUser, GPSOrg

**Data sources**

| Device                        | Values                                                                             | Healthiness | Process | Image | License | User |
|-------------------------------|------------------------------------------------------------------------------------|-------------|---------|-------|---------|------|
| GPS Coordinates:              | 42.642033, 18.1122                                                                 |             |         |       |         |      |
| High-Level Type:              | Sensor                                                                             |             |         |       |         |      |
| Nature:                       | From IOT Device to KB                                                              |             |         |       |         |      |
| Subnature:                    | IoTSensor                                                                          |             |         |       |         |      |
| Value Name:                   | Dubrovnik:orionDubrovnik-UNIFI/camera_Dubrovnik_1_Ploc                             |             |         |       |         |      |
| Device ServiceURI or Data ID: | http://www.disit.org/km4city/resource/iot/orionDubrovnik-UNIFI/Dubrovnik/camera_Du |             |         |       |         |      |
| Sensor ServiceURI or Data ID: | http://www.disit.org/km4city/resource/iot/orionDubrovnik-UNIFI/Dubrovnik/camera_Du |             |         |       |         |      |

Selected (2) | All selected (2)

| Business | Check               | Ownership |
|----------|---------------------|-----------|
| ●        | 2019-08-13 07:18:30 | public    |
| ●        | 2019-08-13 07:18:30 | public    |
| ●        | 2019-08-13 07:18:30 | public    |
| ●        | 2019-08-13 07:18:30 | public    |
| ●        | 2019-08-13 07:18:30 | public    |
| ●        | 2019-08-13 07:17:27 | public    |
| ●        | 2019-08-13 07:17:27 | public    |

**MAP4CITY**

Click with the mouse on it

**Data Inspector Wizard**

Knowledge Base view

Device ServiceURI or Data ID: http://www.disit.org/km4city/resource/iot/orionDubrovnik-UNIFI/Dubrovnik/camera\_Du

Sensor ServiceURI or Data ID: http://www.disit.org/km4city/resource/iot/orionDubrovnik-UNIFI/Dubrovnik/camera\_Du

Datasource: iot

Ownership: private

Organizations: Dubrovnik

[Link to Service Map](#) [Link to IoT Device](#)

**IOT Devices**

| IoT Device                    | IOT Broker               | Device Type       | Model             | Ownership    | Status | Soft | Delete | Location |
|-------------------------------|--------------------------|-------------------|-------------------|--------------|--------|------|--------|----------|
| AccessPoint1_FerniaSuperstore | orionLanatoDeCarde-UNIFI | AccessPointSensor | AccessPointLanato | DELEGATED    | active | EDIT | DELETE |          |
| AccessPoint2_ITIS             | orionLanatoDeCarde-UNIFI | AccessPointSensor | AccessPointLanato | DELEGATED    | active | EDIT | DELETE |          |
| AccessPoint3_Datareport       | orionLanatoDeCarde-UNIFI | AccessPointSensor | AccessPointLanato | DELEGATED    | active | EDIT | DELETE |          |
| adminDev1                     | orionUNIFI               | Ambiental         |                   | MYOWNPRIVATE | active | EDIT | DELETE |          |
| AdminDevice001                | orionUNIFI               | Ambiental         |                   | MYOWNPRIVATE | active | EDIT | DELETE |          |
| AdminDevice002                | orionUNIFI               | Ambiental         |                   | MYOWNPRIVATE | active | EDIT | DELETE |          |
| AdminDevice004                | orionUNIFI               | Ambiental         |                   | MYOWNPRIVATE | active | EDIT | DELETE |          |
| AdminDevice005                | orionUNIFI               | Ambiental         |                   | MYOWNPRIVATE | active | EDIT | DELETE |          |
| AdminTest005                  | orionUNIFI               | Ambiental         |                   | MYOWNPRIVATE | active | EDIT | DELETE |          |

Showing 1 to 10 of 370 entries

Some functionalities are limited to certain roles

# Notation Terminology

| WHERE                                             | Are synonymous at level of service which can be <b>IoT device or entity</b> with data and references to | Are synonymous at level of the single <b>attribute of the entity</b> , device, service, etc. |
|---------------------------------------------------|---------------------------------------------------------------------------------------------------------|----------------------------------------------------------------------------------------------|
| IoT Directory, Entity Directory                   | IoT Device, Entity Instance, Device URI                                                                 | Sensor, Actuator, Attributes, Values (value name)                                            |
| Knowledge Base, ServiceMap, SmartCity API, ASCAPI | Service, ServiceURI, SURI                                                                               | Attribute, Metric                                                                            |
| DataInspector, Wizard, Dashboard                  | Value Name                                                                                              | Sensor, Sensor Actuator, ValueType                                                           |
| IoT App., Proc.Logic, Node-RED                    | ServiceURI, SURI                                                                                        | SURI and its real time results of the objects into the data structure                        |

## ServiceURI, SURI of a sensor device:

- <http://www.disit.org/km4city/resource/METRO759>
- <http://www.disit.org/km4city/resource/iot/orionCAPELON-UNIFI/CAPELON/Streetlight%3A90FD9FFFFE5A7F>

## ServiceURI, SURI extended with attribute/variable/value:

- <http://www.disit.org/km4city/resource/METRO759&metric=vehicleFlow>
- <http%3A%2F%2Fwww.disit.org%2Fkm4city%2Fresource%2FMETRO759&metric=vehicleFlow>
- In some cases
  - <http://www.disit.org/km4city/resource/METRO759/vehicleFlow>

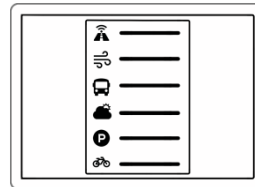

# Dashboard Usage and recipe: Event map target

- **Selector to Show on Map a**

- **category of Map positioned elements**

- [https://servicemap.disit.org/WebAppGrafo/api/v1/?selection=43.08694333811321;8.791809082031252;44.9368500391093;14.065246582031252&categories=Traffic\\_sensor&maxResults=0&maxDists=0.1&text=&model=&value\\_type=&format=json](https://servicemap.disit.org/WebAppGrafo/api/v1/?selection=43.08694333811321;8.791809082031252;44.9368500391093;14.065246582031252&categories=Traffic_sensor&maxResults=0&maxDists=0.1&text=&model=&value_type=&format=json)
- <https://servicemap.disit.org/WebAppGrafo/api/v1/?queryId=e5f39066cd68ffe259ed8877bcee222b&format=json>

- **Entity by Model**

- <https://www.disit.org/superservicemap/api/v1?selection=59.36535064975547;13.457822799682619;59.39031474260852;13.566999435424806&model=SmartLightCapelon&format=json>

- **Single Entity**

- [https://servicemap.disit.org/WebAppGrafo/api/v1/?serviceUri=http://www.disit.org/km4city/resource/iot/orionFirenze2/Firenze/SH\\_20\\_ab\\_new&format=json&fromTime=3-day](https://servicemap.disit.org/WebAppGrafo/api/v1/?serviceUri=http://www.disit.org/km4city/resource/iot/orionFirenze2/Firenze/SH_20_ab_new&format=json&fromTime=3-day)

- **Heatmap among many**

- [https://wmserver.snap4city.org/geoserver/Snap4City/wms?service=WMS&layers=Florence\\_PM10](https://wmserver.snap4city.org/geoserver/Snap4City/wms?service=WMS&layers=Florence_PM10)

- **Traffic flow**

- <https://wmserver.snap4city.org/geoserver/Snap4City/wms?service=WMS&layers=FirenzeFIPILITrafficRealtime&trafficflowmanager=true>
- <https://firenzetraffic.km4city.org/trafficRTDetails/roads/read.php>

- **Origin Destination Map**

- [https://odmm.snap4city.org/api/get?precision=communes&from\\_date=&organization=Toscana&inflow=True&longitude=11.255751&latitude=43.769710&od\\_id=mobile\\_Toscana\\_1000&perc=True](https://odmm.snap4city.org/api/get?precision=communes&from_date=&organization=Toscana&inflow=True&longitude=11.255751&latitude=43.769710&od_id=mobile_Toscana_1000&perc=True)

- **Events which are also PIN on map**

- **Il Service URI as the unique identifier of the Entity**

- <http://www.disit.org/km4city/resource/iot/orionUNIFI/DISIT/METRO632>

Parts 2, 3 and 7

# Data Registration Flow at a Glance

**IOT Devices**

| Device Identifier          | IOT Broker               | Device Type       | Model                | Ownership       | Status | Location |
|----------------------------|--------------------------|-------------------|----------------------|-----------------|--------|----------|
| SEPC2Z74AS00022            | orion@Firenze-UNIFI      | ChargingStation   | ChargingStationModel | PUBLIC          | active |          |
| AccessPoint_FamiliadSupere | orion@LoroDeiCards-UNIFI | AccessPointSensor | AccessPointLoro      | DELEGATED       | active |          |
| AccessPoint_215            | orion@LoroDeiCards-UNIFI | AccessPointSensor | AccessPointLoro      | DELEGATED       | active |          |
| AccessPoint_PalaSport      | orion@LoroDeiCards-UNIFI | AccessPointSensor | AccessPointLoro      | DELEGATED       | active |          |
| admin@Dev1                 | orion@UNIFI              | Ambiental         |                      | UNKNOWN/PUBLIC  | active |          |
| Admin@Device03             | orion@UNIFI              | Ambiental         |                      | UNKNOWN/PRIVATE | active |          |

IOT Directory:  
Devices...  
Sensors...  
Actuators...

**Service Map (Toscana)**

IBIMETAir Quality Sensor - BORGO SAN LORENZO

Service: IBIMETAir Quality Sensor - BORGO SAN LORENZO

Actual Selection:

Service: IBIMETAir Quality Sensor - BORGO SAN LORENZO

Address: BORGO SAN LORENZO  
City: FIRENZE

Address Type

| Value       |
|-------------|
| PM10_5      |
| CO          |
| NO2         |
| CO2         |
| Temperature |
| Humidity    |
| PM2.5       |

Knowledge Base,  
ServiceMap,  
SuperServiceMap  
SmartCity API,  
ASCAPI

**IoT Apps Proc. Logic**

IoT Apps  
Proc. Logic

**Data Inspector**

| High-Low Type | Nature                    | Subnature       | Value Type | Value Name      | Data Type | Value Unit | Last Date           | Last Value | Healthiness | Last Check          | Ownership |
|---------------|---------------------------|-----------------|------------|-----------------|-----------|------------|---------------------|------------|-------------|---------------------|-----------|
| url           | Environment               | Nature          | Nature     | pollution       | GW4FS     |            | 2020-04-03 09:58:18 | 0          | ●●●●●       | 2020-04-03 09:58:18 | public    |
| url           | Environment               | Nature          | Nature     | pollution       | GW4FS     |            | 2020-04-03 09:58:18 | 0          | ●●●●●       | 2020-04-03 09:58:18 | public    |
| url           | Environment               | Nature          | Nature     | www_bioscience  | GW4FS     |            | 2020-04-03 09:58:18 | 0          | ●●●●●       | 2020-04-03 09:58:18 | public    |
| url           | Environment               | Nature          | Nature     | fauna           | GW4FS     |            | 2020-04-03 09:58:18 | 0          | ●●●●●       | 2020-04-03 09:58:18 | public    |
| url           | Environment and Transport | Traffic Sensors | Nature     | Traffic Sensors | GW4FS     |            | 2020-04-03 09:58:18 | 0          | ●●●●●       | 2020-04-03 09:58:18 | public    |

Last Value: 15.9

Time Thread: 3 Apr 01:00 02:00 03:00 04:00 05:00 06:00 07:00 08:00 09:00 10:00

DataInspector  
Dashboard Wizard

create  
Dashboards



TOP

# MyKPI Nodes

Part 3

Part 5

- Data Management, HLT ▲
- Data Inspector
- MyKPI, MyData, MyPOI**
- My Groups of Entities
- View/Set MyPOI on Tuscany
- Data Table Loader (Excel)



- Save and retrieve MyKPI into the safe personal data storage

## ▼ S4CKPIData

get my kpdata

get my kpdata values

get public kpdata values

get delegated kpdata values

save my kpdata values

- Access to MyKPI and to those that other user have delegated to Me
- **MyKPI are:**
  - Time series of data with GPS coordinates that can change over time
  - Suitable for: moving sensors, trajectories, data from OBU, data from mobile, sensor data (if needed), etc. etc.
- **MyPOI are:**
  - POI with full metadata description and static coordinates

TOP

# ***TOOLS for Data Ingestion Verifications***

Part 3

Part 5



# Checking data/Entity ingestion results

## Knowledge base Semantic reasoners



- All searches
- Metata
- Structure
- Last values of IoT Dev
- GTFS
- Only public IoT Dev

## ServiceMap, SCAPI, SuperSM

- LOG / LOD viewer
- Super Service Map
- SCAPI: Swagger
- Last data

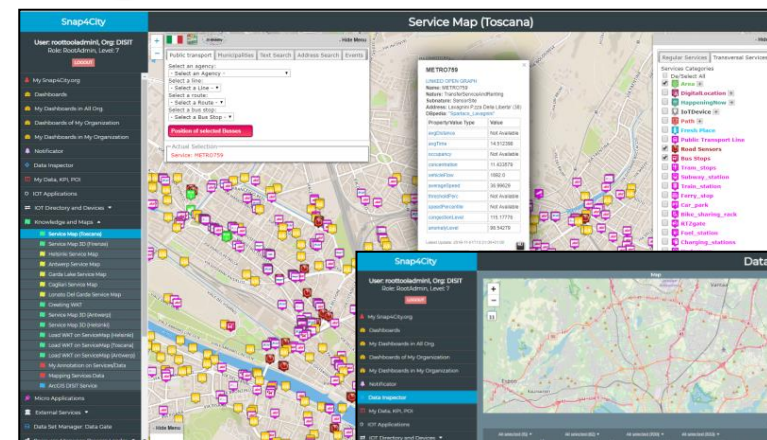

ServiceMap or  
Super ServiceMap

## Data Inspector (last data)

## IoT/Entity Directory

- IoT Brokers

Data Inspector  
Digital Twin view

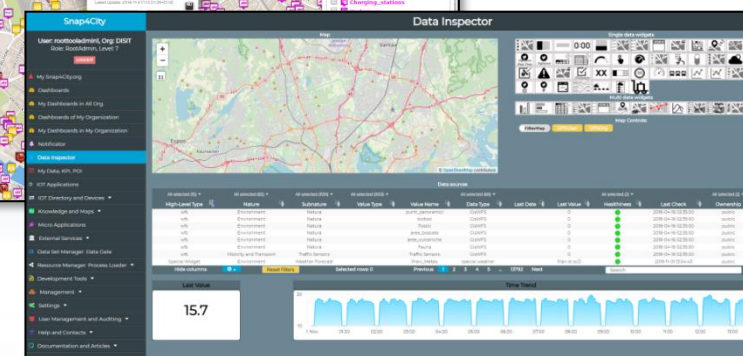

## Indexing and aggregating NIFI, OpenSearch

- Faceted search
- Geo search
- Time Series
- Private and Public

## ServiceMap, SCAPI (last data), SuperSM

## My Data Dashboard, OpenSearchDash

## Data Inspector (last data)

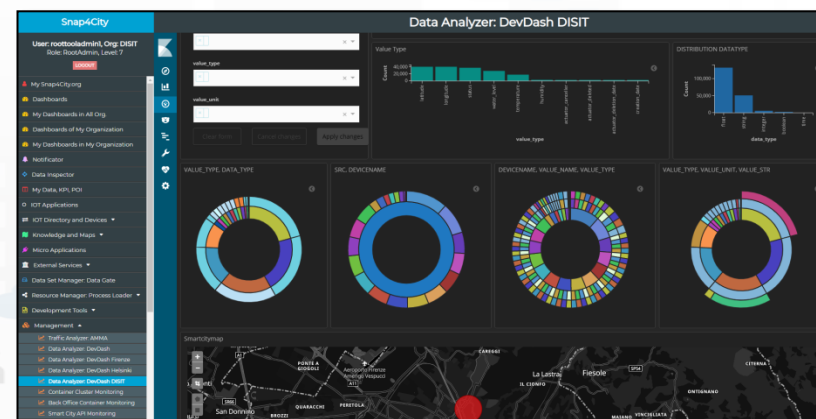

My Data Dashboard

DevDash

# ServiceMaps/Super ServiceMap

**Service Map (Toscana)**

User: rootooladmin1, Org: DISIT  
Role: RootAdmin, Level: 7  
LOGOUT

Public transport | Municipalities | Text Search | Address Search | Events

Select an agency:  
- Select an Agency -  
Select a line:  
- Select a Line -  
Select a route:  
- Select a Route -  
Select a bus stop:  
- Select a Stop -

Position of selected Busses  
Actual Selection  
Bus Stop: Salvemini

**TPL STOP - Salvemini**  
ATAF&LINEA  
Serviceuri: [http://www.disit.org/km4city/resource/Bus\\_ataflinea\\_Stop\\_FM0612\\_500\\_GRAPH](http://www.disit.org/km4city/resource/Bus_ataflinea_Stop_FM0612_500_GRAPH)  
Lines: 14 23 C1 C2  
Display 10 Bus per page Search:

| Time                | Line | Direction                  |
|---------------------|------|----------------------------|
| 09:31:00 2020-10-07 | C1   | Parterre                   |
| 09:33:00 2020-10-07 | 23   | T2 Guidoni                 |
| 09:36:00 2020-10-07 | 14   | Santa Maria Maggiore       |
| 09:38:00 2020-10-07 | C2   | Leopolda T1 Porta Al Prato |
| 09:39:00 2020-10-07 | 23   | T2 Guidoni                 |
| 09:40:00 2020-10-07 | C1   | Parterre                   |

Showing page 1 of 45  
Real-time data currently not available

Regular Services | Transversal Services

Services Categories

- De/Select All
- Accommodation +
- Advertising +
- AgricultureAndLivestock +
- CivilAndEdilEngineering +
- CulturalActivity +
- EducationAndResearch +
- Entertainment +
- Environment +
- FinancialService +
- GovernmentOffice +
- HealthCare +
- IndustryAndManufacturing +
- IoTDevice +
- MiningAndQuarrying +
- ShoppingAndService +
- TourismService +
- TransferServiceAndRenting +
- UtilitiesAndSupply +
- Wholesale +
- WineAndFood +

Filter:  
search text into service  
Service providing value type:  
select value type  
N. results: 100  
Search Range: visible area  
Search Area: select...  
Search Results:  
Services 100 of 60336 available

SNAP4CITY (C), Sept. 2024

**SURRI**

373773207E330127  
LINKED OPEN GRAPH  
Name: lot/orion/Finland/Helsinki/373773207E330127  
Nature: Environment  
Subnature: Air\_quality\_monitoring\_station

| Property/Value Type             | Value                                     |
|---------------------------------|-------------------------------------------|
| PM10                            | 3                                         |
| PM2.5                           | 2                                         |
| dateObserved                    | 2019-10-22T07:59:42.930000+00:00          |
| reliability                     | 0.5                                       |
| source                          | https://vtt.fi/arkisto/laatu2019          |
| airQualityPM10Gral              | 0.2405 @2019-10-22T07:59:42.930000+00:00  |
| airQualityPM10Enfuser           | 2.8207 @2019-10-22T07:59:42.930000+00:00  |
| RealTimeDeltaAQI                | -0.1793 @2019-10-22T07:59:42.930000+00:00 |
| airQualityPM10RealTimeDeltaGral | 2.2595 @2019-10-22T07:59:42.930000+00:00  |
| EnfuserAQI                      | 1.1793 @2019-10-22T07:59:42.930000+00:00  |
| airQualityPM2_5Enfuser          | 0.7086 @2019-10-22T07:59:42.930000+00:00  |
| airQualityPM10RealTimeDelta     | -0.1207 @2019-10-22T07:59:42.930000+00:00 |
| airQualityPM10AverageLastHour   | 2.5 @2019-10-22T07:59:42.930000+00:00     |
| RealTimeAQI                     | 1 @2019-10-22T07:59:42.930000+00:00       |
| airQualityPM2_5AverageLastHour  | 1.9 @2019-10-22T07:59:42.930000+00:00     |
| airQualityPM2_5RealTimeDelta    | 1.1914 @2019-10-22T07:59:42.930000+00:00  |

# Views of the Knowledge Base

Knowledge Base  
Semantic Reasoners

- How pass from ServiceMap to Linked Open Graph, Linked Data view tool

**Linked Open Graph**

Select a SPARQL endpoint: Global Endpoint Map  
Snap4City SmartCity Ontology (by DISIT)  
URI: http://www.disit.org/km4city/resource/lot/orion/Finland/Helsinki/373773207E330127

**Linked Open Graph**

Identifier: http://www.disit.org/km4city/resource/lot/orion/Finland/Helsinki/373773207E330127

Info:

- http://www.w3.org/2003/01/geo/wgs84\_pos#lat: 60.15858
- http://www.w3.org/2003/01/geo/wgs84\_pos#long: 24.921349
- http://schema.org/name: 373773207E330127
- http://www.disit.org/km4city/schema#format: json
- http://www.disit.org/km4city/schema#macaddress: ...

## Linked Open Data

LOG: <https://log.disit.org>

LOD

**Linked Open Graph**

**SiiMobility (by DISIT)**  
Examples:  
• [VIA GIACOMO MATTEOTTI](#)  
• [Baiano a ripoli](#)  
• [Firenze](#)  
Choose a class:  
Search for keyword  
keyw  
uri [http://...](#) Request

**Your data**  
sparql endpoint: (optional)  
[http://...](#)  
uri: [http://...](#) Request  
**Status**  
Requests:  
<http://www.disit.dinfo.unifi.it/SiiMobility/MUSE...>  
Remove Clear

**Type of relations**  
Select all Deselect all Invert Hide all inverse  
 belongTo  
 contains  
 ends  
 has  
 hasExternalAccess  
 hasProvince  
 hasStreetNumber  
 isIn  
 isPartOfProvince  
 managingAuthority  
 placedIn  
 seeAlso  
 coincideWith  
 depiction  
 forming  
 hasAccess  
 hasMunicipality  
 hasRule  
 inMunicipalityOf  
 isPartOf  
 isPartOfRegion  
 ownerAuthority  
 sameAs  
 starts

**Linked Open Graph**

Schema: <http://www.disit.org/km4city/schema>  
 RDF version: <http://www.disit.org/km4city.rdf>

## Snap4City

Switch To New Layout (Beta)

User: paolo.disit, Org: DISIT  
Role: AreaManager, Level: 3

LOGOUT

www.snap4solutions.org

Dashboards (Public)

Dashboards of My Organization

My Dashboards in My Organization

My Data Dashboard Dev Kibana

Extra Dashboard Widgets

Data Management, HLT

Data Inspector

MyKPI, MyData, MyPOI

My Groups of Entities

View/Set MyPOI on Tuscany

Data Table Loader (Excel)

POI Loader (Excel)

Harvest Satellite Copernicus Data

File Manager

HeatMap Manager

BIM Server old

BIM Server New

BIM Srv New: Add

BIM Srv new: View

OpenData Manager: Data Gate

OpenData Manager: Data Gate

Add Data Sources into the Platform

Doc: Data Table Loader

Doc: POI Loader

## Data Inspector

Map

**METRO729**

VALUE NAME: METRO729

|                 | DESCRIPTION              | DESCRIPTION | RT DATA    |              |               |             |
|-----------------|--------------------------|-------------|------------|--------------|---------------|-------------|
| avgTime         | 11.11040                 |             | value      | 4 hours      | 24 hours      | 7 days      |
| concentration   | 9.503457                 |             | Last value | Last 4 hours | Last 24 hours | Last 7 days |
| congestionLevel | 104.27637                |             | Last value | Last 4 hours | Last 24 hours | Last 7 days |
| dateObserved    | 2023-07-29T08:56:00.000Z |             | Last value | Last 4 hours | Last 24 hours | Last 7 days |
| vehicleFlow     | 1356                     |             | Last value | Last 4 hours | Last 24 hours | Last 7 days |

Single data widgets  
Multi data widgets

Map Controls:

Now displaying In Standard Mode

Switch to the Synoptic Mode to select MyKPIs and sensors that you need for your synoptics.

[Switch now to the Synoptic Mode](#)

### Data sources

| High-Level Type | Nature                    | Subnature      | Device/Mode | Broker     | Value Name | Value Type | Data Type  | Value Unit | Last Date           | Last Value | Healthiness | Last    |
|-----------------|---------------------------|----------------|-------------|------------|------------|------------|------------|------------|---------------------|------------|-------------|---------|
| IoT Device      | TransferServiceAndRenting | Traffic_sensor | METRO792    | orionUNIFI |            |            | sensor_map |            | 2023-07-28 13:26:00 |            |             | 2023-07 |
| IoT Device      | TransferServiceAndRenting | Traffic_sensor | METRO791    | orionUNIFI |            |            | sensor_map |            | 2023-07-28 13:26:00 |            |             | 2023-07 |
| IoT Device      | TransferServiceAndRenting | Traffic_sensor | METRO793    | orionUNIFI |            |            | sensor_map |            | 2023-07-28 13:16:00 |            |             | 2023-07 |
| IoT Device      | TransferServiceAndRenting | Traffic_sensor | METRO713    | orionUNIFI |            |            | sensor_map |            | 2023-07-28 13:16:00 |            |             | 2023-07 |
| IoT Device      | TransferServiceAndRenting | Traffic_sensor | METRO729    | orionUNIFI |            |            | sensor_map |            | 2023-07-28 13:16:00 |            |             | 2023-07 |
| IoT Device      | TransferServiceAndRenting | Traffic_sensor | METRO7      | orionUNIFI |            |            | sensor_map |            | 2023-07-28 13:16:00 |            |             | 2023-07 |
| IoT Device      | TransferServiceAndRenting | Traffic_sensor | METRO760    | orionUNIFI |            |            | sensor_map |            | 2023-07-28 13:16:00 |            |             | 2023-07 |
| IoT Device      | TransferServiceAndRenting | Traffic_sensor | METRO799    | orionUNIFI |            |            | sensor_map |            | 2023-07-28 13:16:00 |            |             | 2023-07 |

vehicleFlow

1356

vehicleFlow - 7 days



# Data Inspector for Beginner

- Browse and see models data via HLT, nature and Subnature
  - All the other faceted views, search and filter, filter by map, etc.
- Identify, click them to see
  - Remaining icons representing dashboard widgets which can be used in the Dashboard Wizard
  - ICON: Click on the icon on map and on value to preview data time serie if any
- See detailed Digital Twin data on the microbutton of the healthiness
- Wider data preview is coming

# DevDash: My Data Dashboard

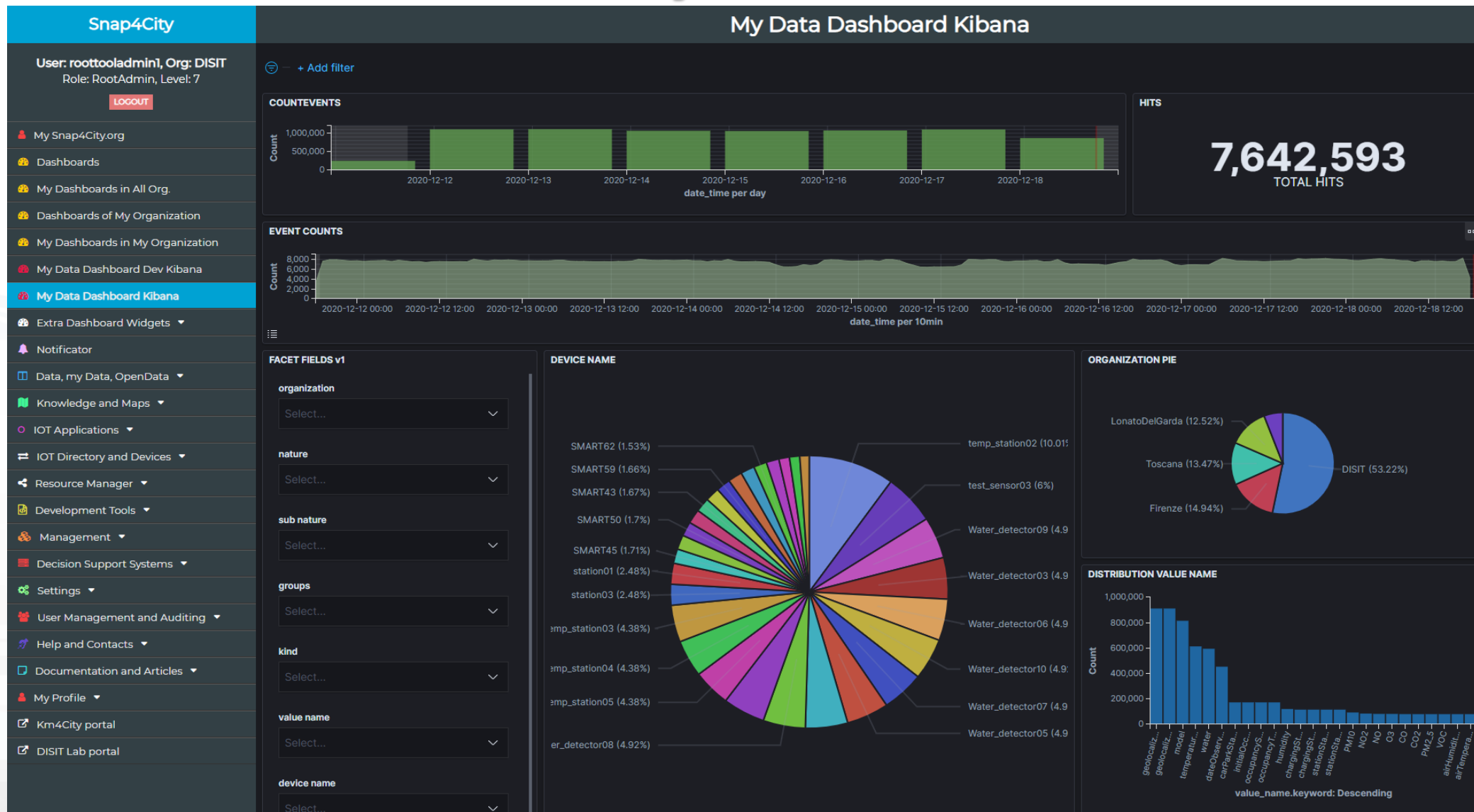

# *Data Managers*



# Data Managers

|                                       |
|---------------------------------------|
| ☐ Data Management, HLT ▾              |
| ◆ Data Inspector                      |
| ☐ MyKPI, MyData, MyPOI                |
| 🗺 My Groups of Entities               |
| 🗺 View/Set MyPOI on Tuscany           |
| ☐ Data Table Loader (Excel)           |
| ☐ POI Loader (Excel)                  |
| ⇕ Harvest Satellite Copernicus Dat... |
| ◆ Data Inspector OpenSearch           |
| 📁 File Manager                        |
| 📍 HeatMap Manager                     |
| 📍 ColorMap Manager                    |
| 📈 TypicalTimeTrend Manager            |
| 📍 TrafficFlow Manager                 |
| 📺 TVCam Manager                       |
| 📍 OD Manager                          |
| 📺 BIM Manager                         |
| 📺 BIM Server old                      |
| 📺 BIM Server New                      |
| 📺 BIM Srv New: Add                    |
| 📺 BIM Srv new: View                   |
| 🔒 OpenData Manager: Data Gate         |
| 🔒 OpenData Manager: Data Gate         |
| ⇕ OpenData Harvester: Data Gate...    |

- Data Inspector
- MyKPI....
- File Manager
- HeatMap Manager
- Typical Time Trend Manager
- TV Cam Manager
- OD, Origin Destination Matrix Manager
- Bim Manager
- Open Data Manager

# HeatMap Manager

Snap4City

HeatMap Manager

Switch To New Layout (Beta)

User: roottooladmin1, Org: DISIT  
Role: RootAdmin, Level: 7

LOGOUT

- My Snap4City.org
- Tour Again
- www.snap4solutions.org
- ダッシュボード
- Dashboards (Public)
- My Dashboards in All Org.
- Dashboards of My Organization
- My Dashboards in My Organization
- My Data Dashboard Dev Kibana
- My Data Dashboard Kibana
- Extra Dashboard Widgets ▾
- Notificator
- Data Management, HLT ▲
  - Data Inspector
  - MyKPI, MyData, MyPOI
  - My Groups of Entities
  - View/Set MyPOI on Tuscany
  - Data Table Loader (Excel)
  - POI Loader (Excel)

Show 15 Search:

| Map name                                   | Color Map                                               | Owner                | Nature           | Subnature      | Organization | Details              | Management           | View Data                                       | Delete              |
|--------------------------------------------|---------------------------------------------------------|----------------------|------------------|----------------|--------------|----------------------|----------------------|-------------------------------------------------|---------------------|
| 15MinIndex_AbitantiPerPunto                | <a href="#">VIEW</a> <a href="#">EDIT</a> 15minsubindex | <a href="#">VIEW</a> | CulturalActivity | Cultura_centre | DISIT        | <a href="#">VIEW</a> | <a href="#">EDIT</a> | <a href="#">VIEW</a><br><a href="#">PREVIEW</a> | <a href="#">DEL</a> |
| 15MinIndex_AverageIndex                    | <a href="#">VIEW</a> <a href="#">EDIT</a> 15minsubindex | <a href="#">VIEW</a> |                  |                | DISIT        | <a href="#">VIEW</a> | <a href="#">EDIT</a> | <a href="#">VIEW</a><br><a href="#">PREVIEW</a> | <a href="#">DEL</a> |
| 15MinIndex_AverageIndexBologna             | <a href="#">VIEW</a> <a href="#">EDIT</a> 15minsubindex | <a href="#">VIEW</a> |                  |                | DISIT        | <a href="#">VIEW</a> | <a href="#">EDIT</a> | <a href="#">VIEW</a><br><a href="#">PREVIEW</a> | <a href="#">DEL</a> |
| 15MinIndex_CityIndexMP1                    | <a href="#">VIEW</a> <a href="#">EDIT</a> 15minsubindex | <a href="#">VIEW</a> |                  |                | DISIT        | <a href="#">VIEW</a> | <a href="#">EDIT</a> | <a href="#">VIEW</a>                            | <a href="#">DEL</a> |
| 15MinIndex_CultureAndCultsIndex            | <a href="#">VIEW</a> <a href="#">EDIT</a> 15minsubindex | <a href="#">VIEW</a> |                  |                |              |                      |                      |                                                 |                     |
| 15MinIndex_CultureAndCultsIndexBologna     | <a href="#">VIEW</a> <a href="#">EDIT</a> 15minsubindex | <a href="#">VIEW</a> |                  |                |              |                      |                      |                                                 |                     |
| 15MinIndex_EconomyIndex                    | <a href="#">VIEW</a> <a href="#">EDIT</a> 15minsubindex | <a href="#">VIEW</a> |                  |                |              |                      |                      |                                                 |                     |
| 15MinIndex_EconomyIndexBologna             | <a href="#">VIEW</a> <a href="#">EDIT</a> 15minsubindex | <a href="#">VIEW</a> |                  |                |              |                      |                      |                                                 |                     |
| 15MinIndex_EducationIndex                  | <a href="#">VIEW</a> <a href="#">EDIT</a> 15minsubindex | <a href="#">VIEW</a> |                  |                |              |                      |                      |                                                 |                     |
| 15MinIndex_EducationIndexBologna           | <a href="#">VIEW</a> <a href="#">EDIT</a> 15minsubindex | <a href="#">VIEW</a> |                  |                |              |                      |                      |                                                 |                     |
| 15MinIndex_EntertainmentSocialIndex        | <a href="#">VIEW</a> <a href="#">EDIT</a> 15minsubindex | <a href="#">VIEW</a> |                  |                |              |                      |                      |                                                 |                     |
| 15MinIndex_EntertainmentSocialIndexBologna | <a href="#">VIEW</a> <a href="#">EDIT</a> 15minsubindex | <a href="#">VIEW</a> |                  |                |              |                      |                      |                                                 |                     |

HeatMap Manager

Show 15

Preview Heatmap

# TrafficFlow Manager

Snap4City

Switch To New Layout (Beta)

User: roottooladmin1, Org: DISIT  
Role: RootAdmin, Level: 7

LOGOUT

- Data Management, HLT
  - Data Inspector
  - MyKPI, MyData, MyPOI
  - My Groups of Entities
  - View/Set MyPOI on Tuscany
  - Data Table Loader (Excel)
  - POI Loader (Excel)
  - Harvest Satellite Copernicus Data
  - Data Inspector OpenSearch
  - File Manager
  - HeatMap Manager
  - ColorMap Manager
  - TypicalTimeTrend Manager
  - TrafficFlow Manager**
  - TVCam Manager
  - OD Manager
  - BIM Manager
  - BIM Server old
  - BIM Server New
  - BIM Srv New: Add
  - BIM Srv new: View
  - OpenData Manager: Data Gate
  - OpenData Manager: Data Gate
  - OpenData Harvester: Data Gate
  - Add Data Sources into the Platform
  - Doc: Data Table Loader

TrafficFlow Manager

Show 15

Search

| Flux Name                                       | Locality          | Organization | Scenario            | Instances | View Data | Metric         | ColorMap                    | Delete | Preview | Unit of Measure |
|-------------------------------------------------|-------------------|--------------|---------------------|-----------|-----------|----------------|-----------------------------|--------|---------|-----------------|
| cinque                                          | nomedelloscenario | Toscana      | cinque              | 3         | VIEW      | TrafficDensity | VIEW EDIT densityTrafficMap | DEL    | PREVIEW | vehicle per 20m |
| FirenzeFIPILITrafficRealtime                    | FirenzeFIPILI     | Toscana      | TrafficRealtime     | 114241    | VIEW      | TrafficDensity | VIEW EDIT densityTrafficMap | DEL    | PREVIEW | vehicle per 20m |
| FirenzeFIPILITrafficScenarioScenariobefore      | FirenzeFIPILI     | Toscana      | Scenariobefore      | 1         | VIEW      | TrafficDensity | VIEW EDIT densityTrafficMap | DEL    | PREVIEW | vehicle per 20m |
| FirenzeFIPILITrafficScenarioScenarioAFeb2020    | FirenzeFIPILI     | Toscana      | ScenarioAFeb2020    | 14        | VIEW      | TrafficDensity | VIEW EDIT densityTrafficMap | DEL    | PREVIEW | vehicle         |
| FirenzeFIPILITrafficScenarioScenarioAFeb2020TTT | FirenzeFIPILI     | Toscana      | ScenarioAFeb2020TTT | 14        | VIEW      |                |                             |        |         |                 |
| FirenzeFIPILITrafficScenarioScenarioANov2019    | FirenzeFIPILI     | Toscana      | ScenarioANov2019    | 14        | VIEW      |                |                             |        |         |                 |
| FirenzeFIPILITrafficScenarioScenarioANov2019TTT | FirenzeFIPILI     | Toscana      | ScenarioANov2019TTT | 14        | VIEW      |                |                             |        |         |                 |
| FirenzeFIPILITrafficScenariostefano2            | FirenzeFIPILI     | Toscana      | stefano2            | 4         | VIEW      |                |                             |        |         |                 |
| FirenzeFIPILITrafficScenariostefano2TTT         | FirenzeFIPILI     | Toscana      | stefano2TTT         | 4         | VIEW      |                |                             |        |         |                 |
| FirenzeFIPILITrafficScenariostefano3            | FirenzeFIPILI     | Toscana      | stefano3            | 7         | VIEW      |                |                             |        |         |                 |
| FirenzeFIPILITrafficScenariostefano3TTT         | FirenzeFIPILI     | Toscana      | stefano3TTT         | 7         | VIEW      |                |                             |        |         |                 |
| FirenzeFIPILITrafficScenariostefano5            | FirenzeFIPILI     | Toscana      | stefano5            | 8         | VIEW      |                |                             |        |         |                 |
| FirenzeFIPILITrafficScenariostefano5TTT         | FirenzeFIPILI     | Toscana      | stefano5TTT         | 8         | VIEW      |                |                             |        |         |                 |
| FirenzeFIPILITrafficScenariostefano6            | FirenzeFIPILI     | Toscana      | stefano6            | 5         | VIEW      |                |                             |        |         |                 |

TrafficFlow Manager

Preview Traffic flow

Free street  
Fluid traffic  
Heavy traffic  
Very heavy  
Sensor position

FirenzeFIPILITrafficRealtime  
Traffic Heatmap Controls:  
Max Opacity: 1  
2024-19-01 23:00:00

Cancel

TOP

# Design & Develop of Data Analytics

## (here only overview of Tools)

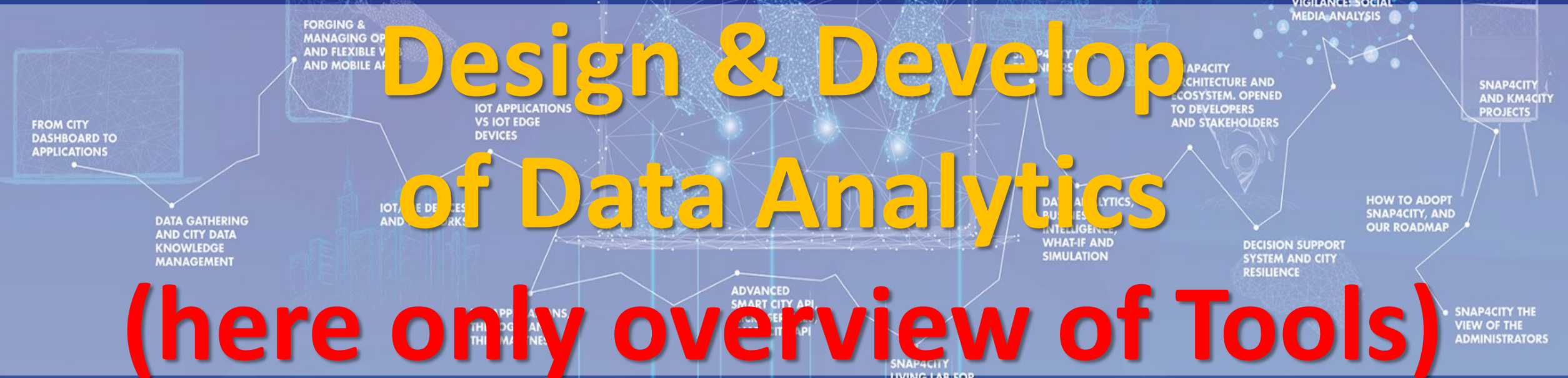

### Part 4

TOP

FROM CITY DASHBOARD TO APPLICATIONS

FORGING & MANAGING OPEN AND FLEXIBLE WEB AND MOBILE APPS

IOT APPLICATIONS VS IOT EDGE DEVICES

IOT/IOE DEVICES AND NETWORKS

SNAP4CITY FOR BEGINNERS

SNAP4CITY ARCHITECTURE AND ECOSYSTEM. OPENED TO DEVELOPERS AND STAKEHOLDERS

TWITTER VIGILANCE: SOCIAL MEDIA ANALYSIS

SNAP4CITY AND KM4CITY PROJECTS

DATA ANALYTICS, BUSINESS INTELLIGENCE

HOW TO ADOPT SNAP4CITY, AND OUR ROADMAP

# For more details on Developing

# Data Analytics, ML, AI, XAI simulation, etc.

# see Part 4 of this training course



# Technical Architecture

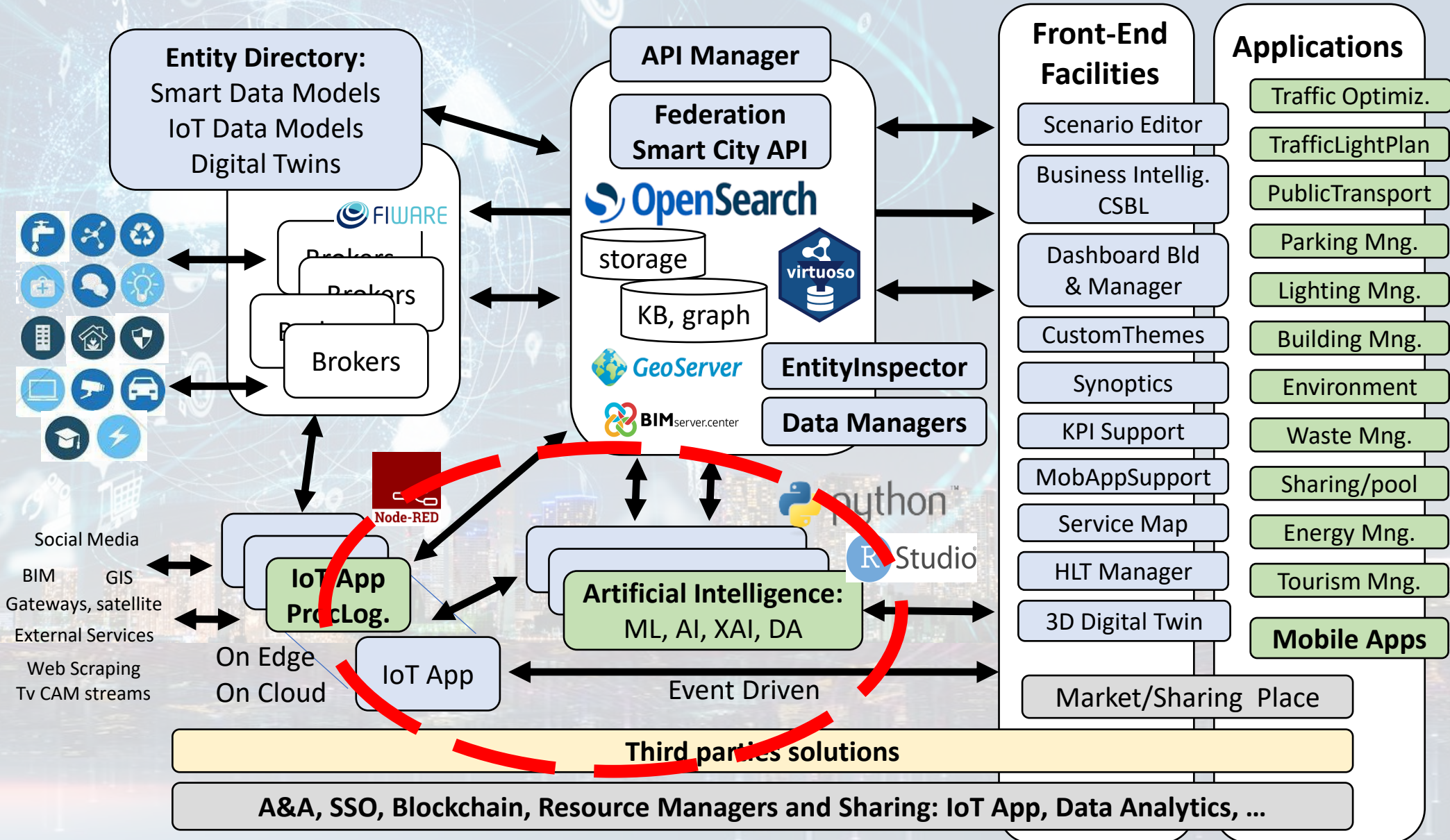

# Development Life Cycle Smart Solutions

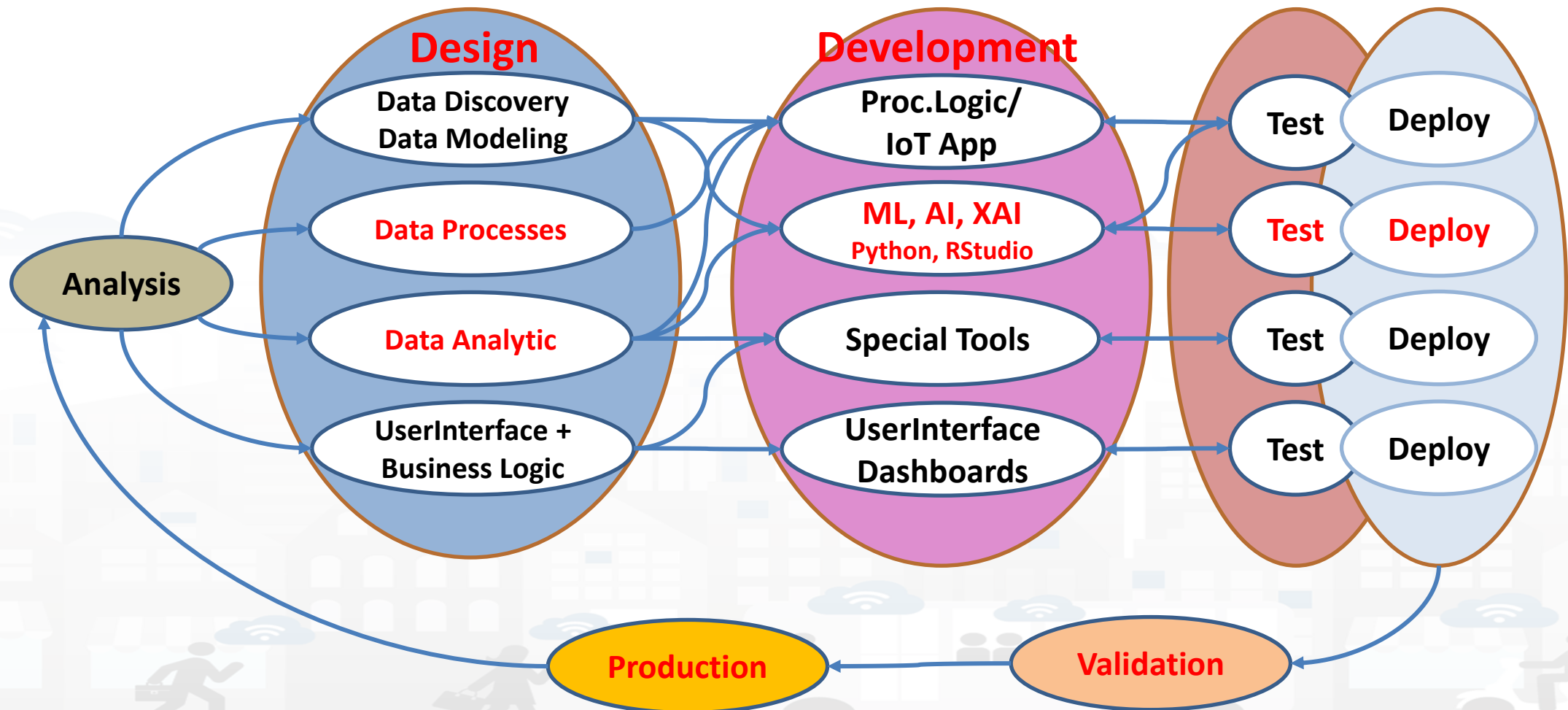

1

# Developer in R Studio + Tensor Flow

**R Studio Development**

```

110 anomaliesMatr[, "timestamp"] <- as.character(dataFinal$res$anoms$index, "alignDateTime")
111 anomaliesMatr[, "anoms"] <- as.numeric(res$anoms[, "anoms"])
112
113 #table with anomalies
114
115 setwd(outD)
116 options(digits = 1)
117 tTable <- tableRob(anomaliesMatr, rows = NULL, cols = c("Date and Time", "Anomaly"), theme=ttheme_default(base_size=12))
118 grid.draw(tTable)
119 h <- convertHeight(sum(tTable$heights), "in", TRUE)
120 w <- convertWidth(sum(tTable$widths), "in", TRUE)
121
122 plot <- res$plot
123
124 plotMtx <- grid.arrange(plot, tTable,
125                       ncol = 2,
126                       heights=c(5,1),
127                       as.table=TRUE)
128
129 setwd(outD)
130 ggsave(paste(columnsName[i], "Anomalies.png"), plotMtx, width=22, height=h*5)
131
132 }, finally = {
133 }
134
135 statisticsResult[[indFolder]]$resultFiles[indResult]$sensor=NULL
136 statisticsResult[[indFolder]]$resultFiles[indResult]$sensor=unbox(as.character(columnsName[i]))
137 statisticsResult[[indFolder]]$resultFiles[indResult]$png=unbox(paste(outD, paste(columnsName[i], "Anomalies.png"), sep=""), indResult = indResult + 1)
138
139 }else{
140   print(paste("NO ANOMALIES ON THE SENSOR ", "-", columnsName[i], "-", sep=""))
141 }
142
143
144 }
145
146 setwd("~/Snap4City")
147 write(jsonlite::toJSON(statisticsResult[[1]]), "JsonStatisticsResult.json")
148 return(statisticsResult[[1]])
149 }
150
151

```

**Files** | Plots | Packages | Help | Viewer

- Home
- nohup.out
- R
- Snap4City
- Snap4CityDEMO
- Snap4CityOld
- StatisticsOutput
  - AverageSpeedDailyTrend.png
  - CarParksDailyTrend.png
  - CorrelationMatrix.png
  - PredictedFreeParking.png
  - SensorsMeanPerDayMoment.png
  - StatisticsBySensors.png
  - StatisticsBySensorsAndDayMoment.png
  - VehicleFlowDailyTrend.png

**Environment** | History | Connections

- Global Environment
- dataFinal: 2794 obs. of 18 variables
- dataset: 35539 obs. of 12 variables
- dataTest: 97 obs. of 15 variables
- dataTestFinal: 97 obs. of 3 variables
- dataTrain: 2793 obs. of 15 variables
- meltDataTest: 97 obs. of 4 variables
- p3: Large gtable (784 elements, 9.2 Mb)
- plt: List of 9
- statisticsResult: List of 1

**Files** | Plots | Packages | Help | Viewer

Home > Snap4City > StatisticsOutput

**Name**

- AverageSpeedDailyTrend.png
- CarParksDailyTrend.png
- CorrelationMatrix.png
- PredictedFreeParking.png
- SensorsMeanPerDayMoment.png
- StatisticsBySensors.png
- StatisticsBySensorsAndDayMoment.png
- VehicleFlowDailyTrend.png

**Click on each .png file to visualize the statistics: a new tab will be opened**

# Snap4City Tools

vs

# Development Life Cycle

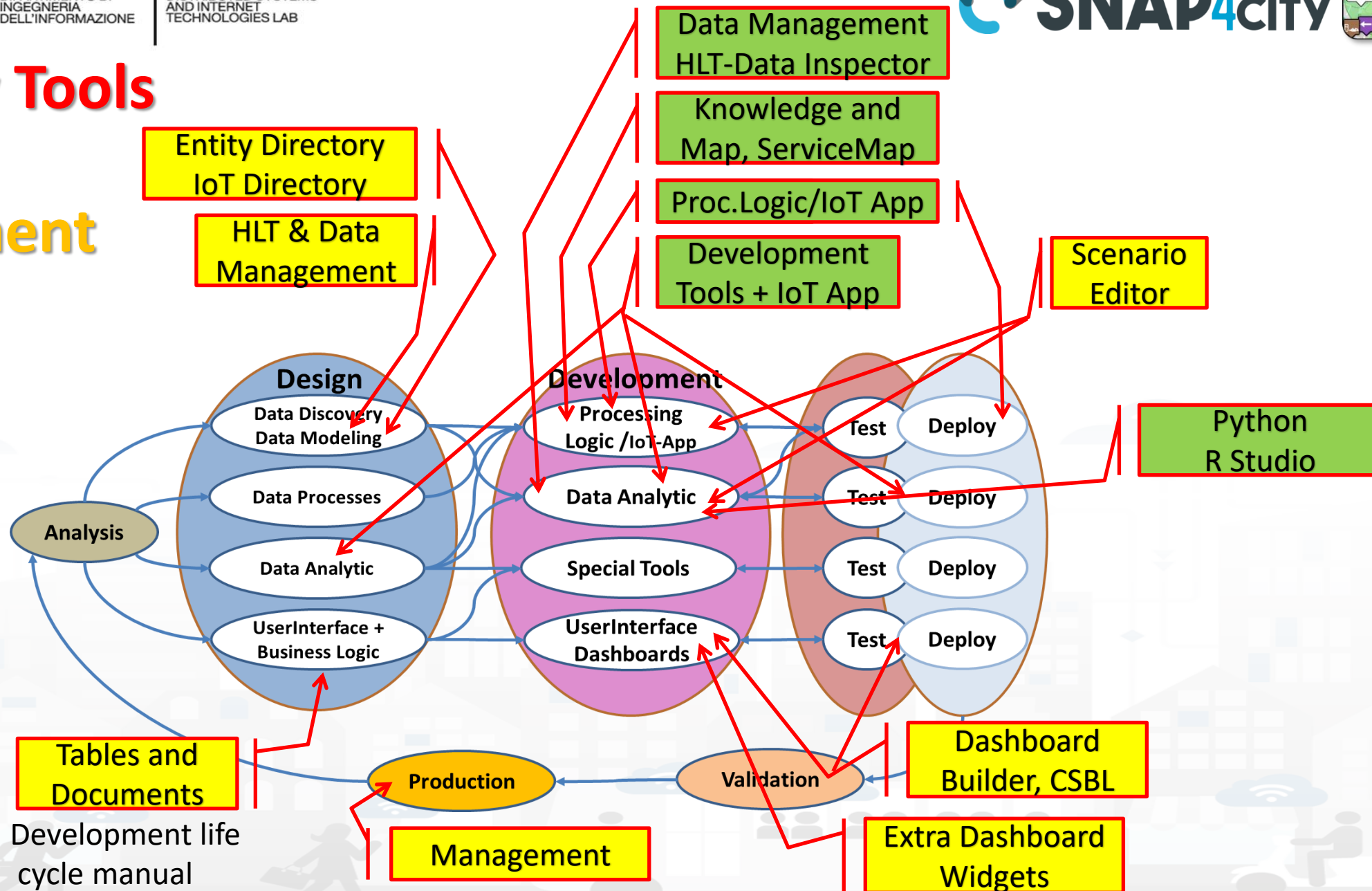

Development life cycle manual

# Snap4City Tools

vs

# Development Life Cycle

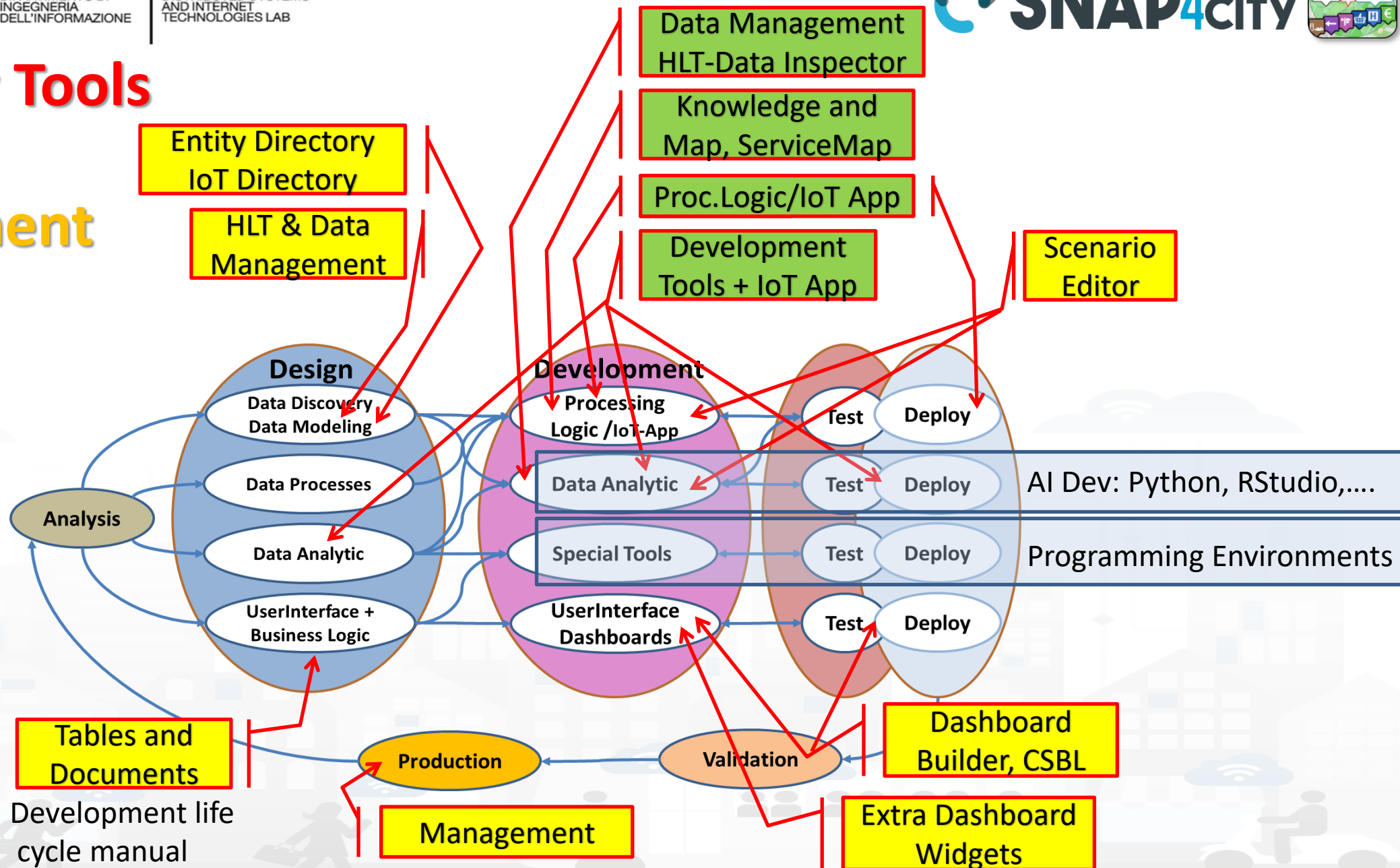

# Model/Technique Development/testing

- **Identification of Process goals and Planning**
  - Which goals
  - How to compute, which language
  - Which environment, which libraries
- **Data Discovery and Ingestion (from the general life cycle)**
- **Data Analysis: feature engineering, feature selection**
- **Data review and preparation for the model**
- **Model Identification and building: ML, AI, etc....**
  - Training
  - Tuning hyperparameters when possible
- **Model Assessment and Selection**
  - Validation in testing
  - Assessment on a set of metrics depending on the goals: global relevant and feature assessment
  - Assessing computational costs
  - Impact Assessment, Ethic Assessment and incidental findings
  - Global and Local Explanation via Explainable AI techniques
- **Model Deploy and Final Validation**
  - Optimisation of computation cost for features, if needed reiterate
- **Solution on Production (security, scalability, etc.)**

## Part 4

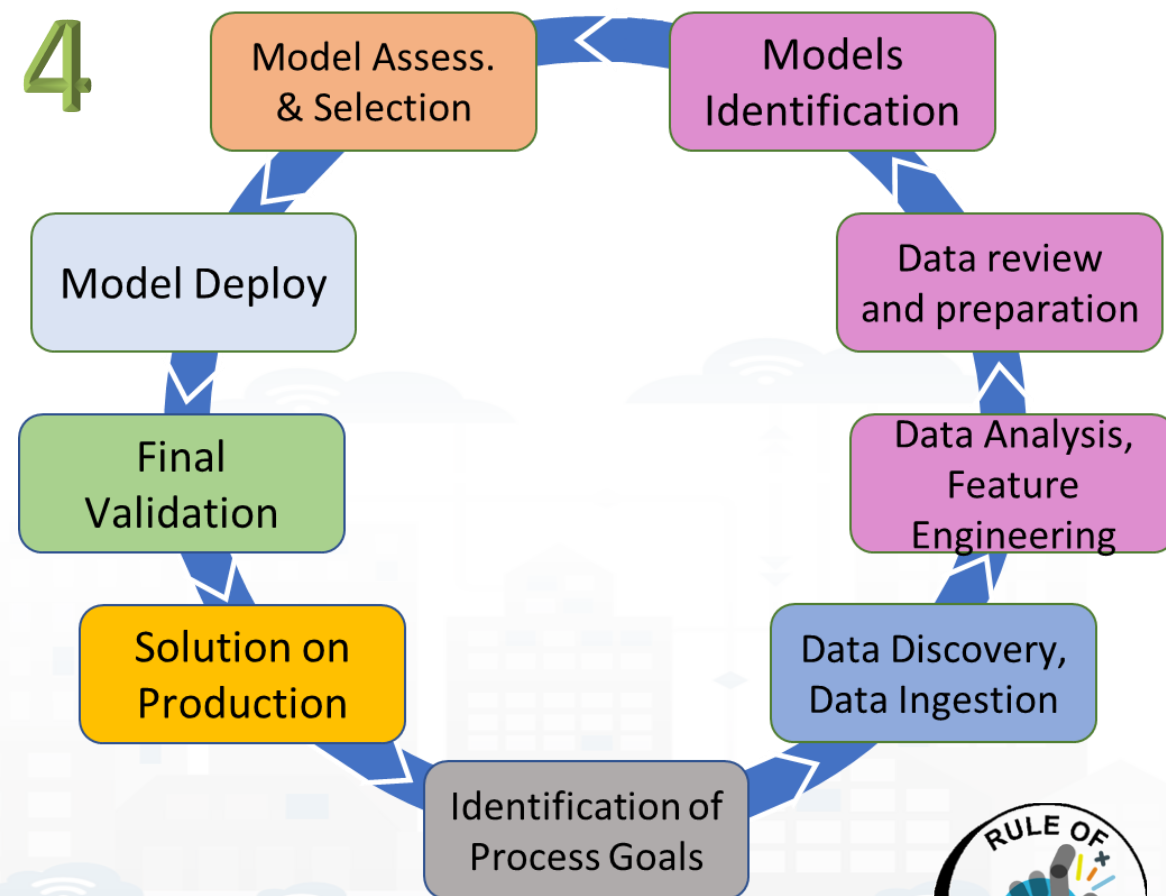

TOP

# *Scenario Editor:* *Snap4City Infrastructures*



# Snap4City Tools

vs

# Development Life Cycle

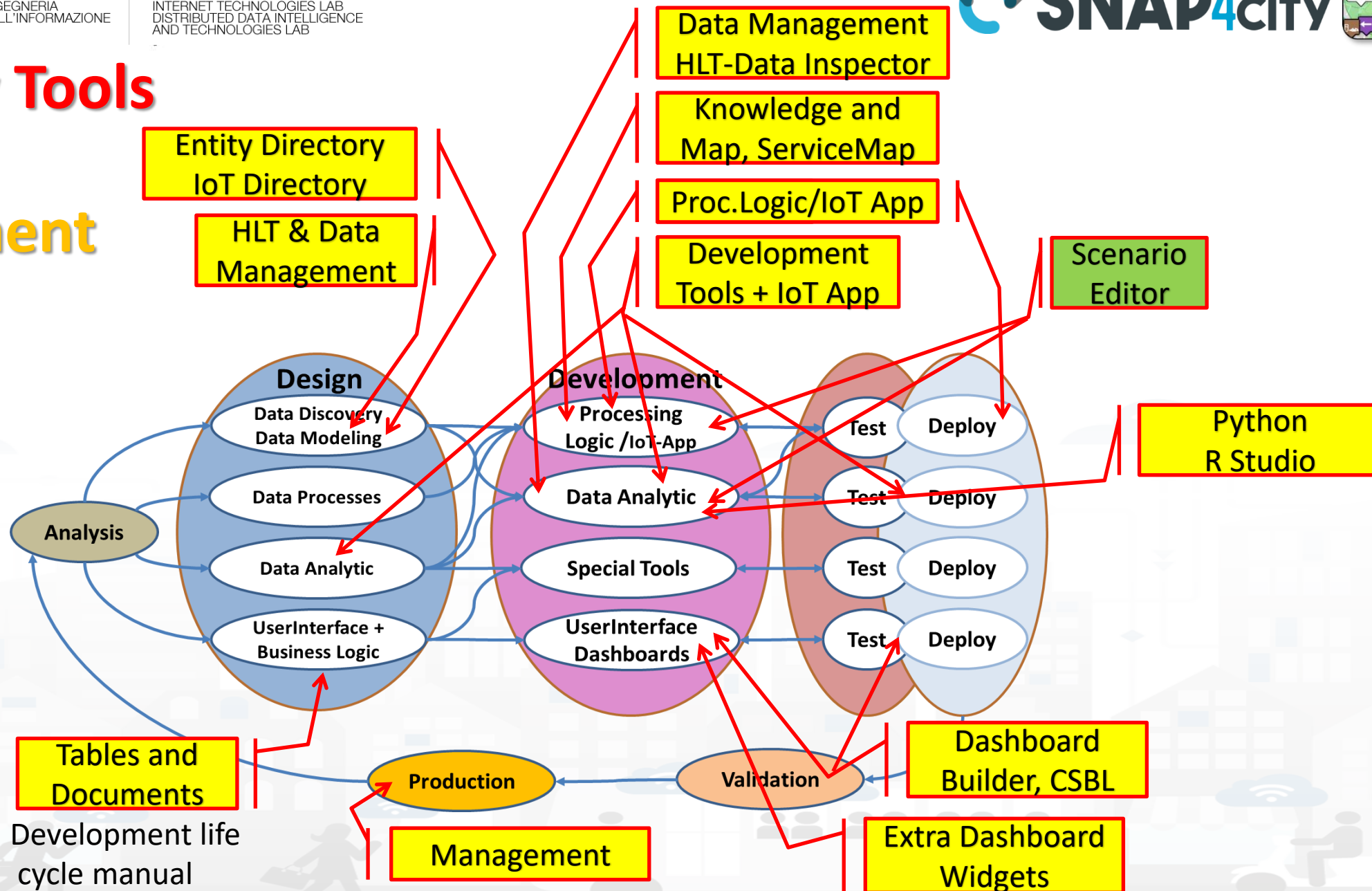



Ciao roottooladmin!

Wed 14 Feb 22:40:02

## FIRENZE - TRAFAIR - AIRQUALITY HEATMAPS - NEWGUI

This dashboard contains data derived from actual sensors and predictive values under validation



- U3 Heatmap
- NO2 Heatmap
- Europ. AQI Heatmap
- Air Humidity Heatmap
- Air Temp. Heatmap
- Wind Speed Heatmap
- Gral Pred. HM NOX (3m)
- Gral Pred. HM NOX (6m)
- Traffic Sensors
- Traffic Flow

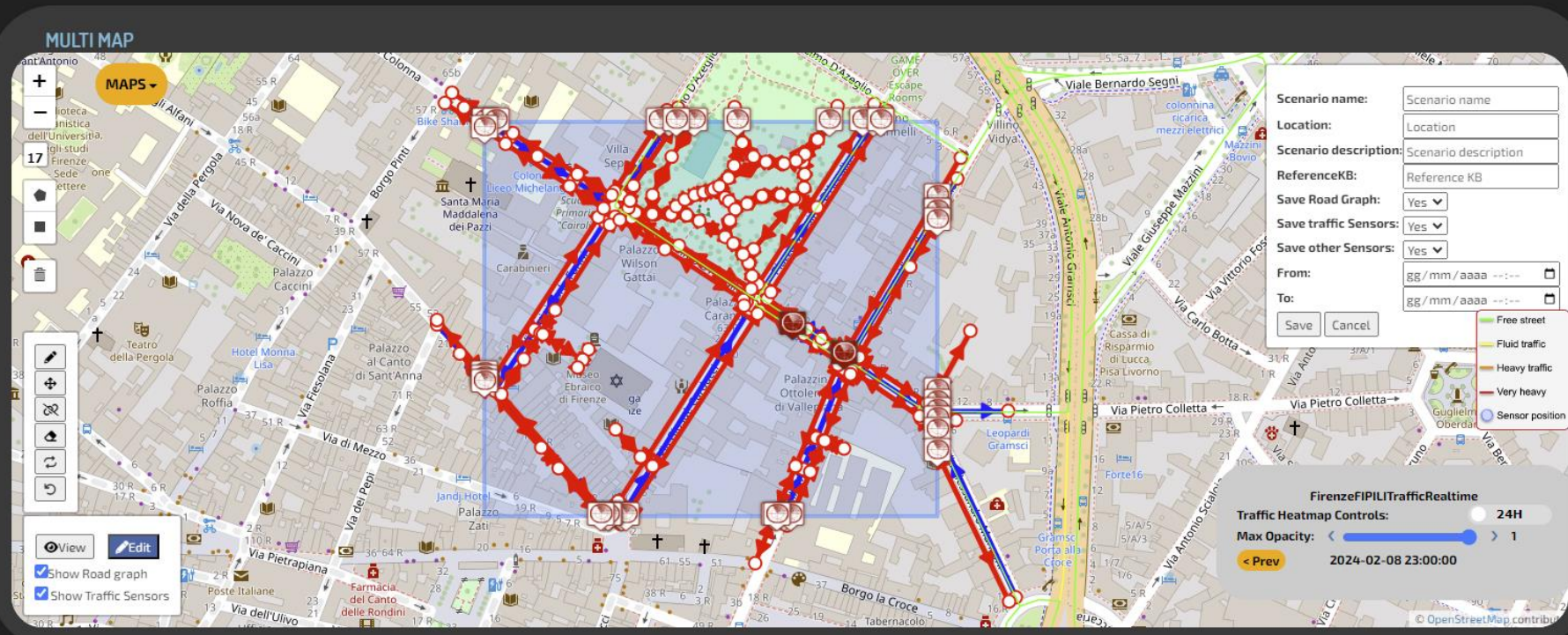

- Firenze Air quality trends
- Firenze GRAL Scenario
- TraFair Main Dashboard

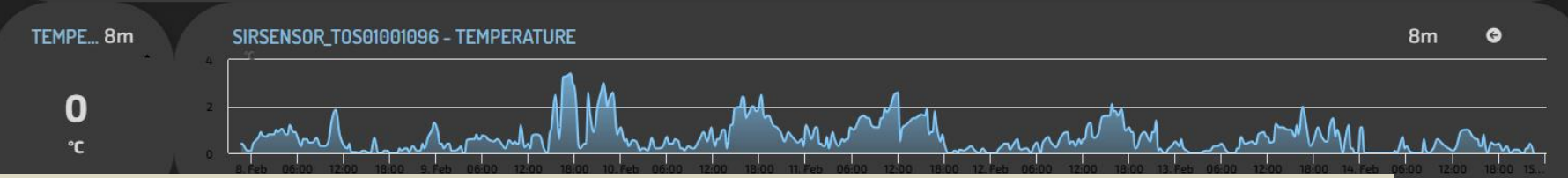

<https://www.snap4city.org/dashboardSmartCity/view/Baloon-Dark.php?iddashboard=MzQyMw==>

Select map

Zoom

The screenshot shows the Scenario Editor interface. On the left, there are map controls for zooming and selecting a map. The main area displays a map with various road segments, some highlighted in blue and green. A configuration panel on the right allows editing a road segment, with fields for Scenario name, Location, Scenario description, Reference KB, and options to save road graphs and sensors. Below this is a 'Category Street' panel with fields for Nr. Lanes, Speed Limit (km/h), Direction, and Restrictions. At the bottom, a 'Road Types' panel lists various road categories with checkboxes for selection. A 'View/Edit' panel at the bottom left shows options to show road graphs and traffic sensors, and a filter by road types button.

Edit Road Segment

New Scenario

Editing

Drag & drop

Split & Join

Delete

Do and Undo

|                 |
|-----------------|
| identifier      |
| composition     |
| elemLocation    |
| elementClass    |
| elementType     |
| length          |
| operatingStatus |
| speedLimit      |
| trafficDir      |
| width           |
| highwayType     |
| route           |

# The actual Scenario Exploitation

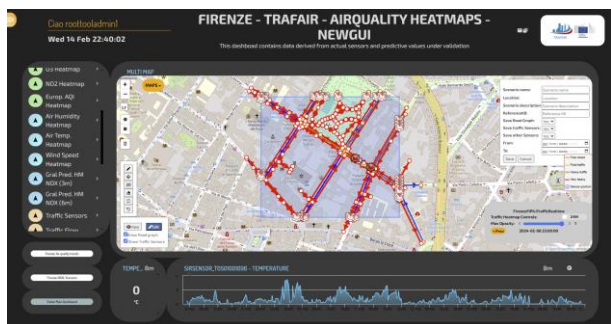

Defining Context via Editing Scenario:

- Select area and data
- Editing roads, POI, IoT entities, ..
- Save/load, share
- Change status

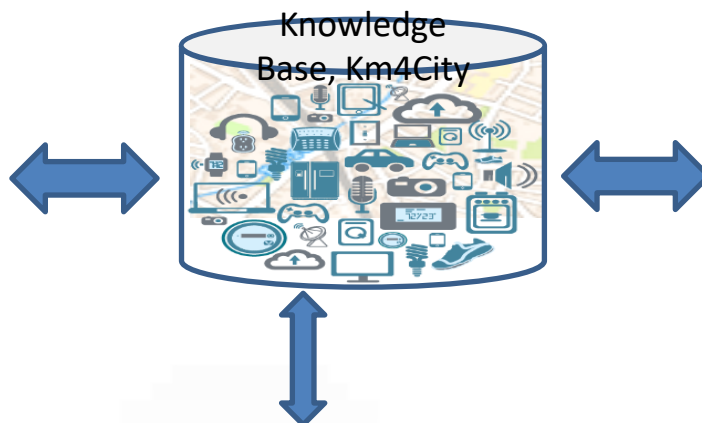

A Scenario includes:

- Metadata
- Status and versions, date time
- Period of validity
- Road graphs, cycling, pedestrian seg.
- List of data, sensors
- Etc.

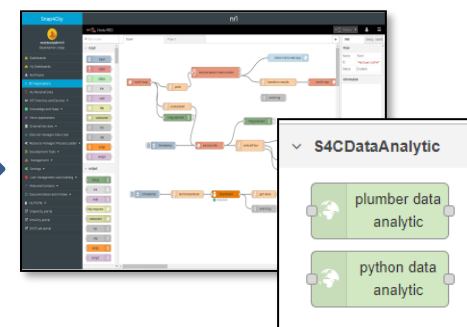

Computing in the Scenario Context as:

- KPI, Metrics, SUMI, SUMP, 15MinCity Index
- Heatmaps
- OD Matrices
- Traffic Flow reconstructions
- Predictions
- Routing, constrained routing
- Early Warnings
- Etc.

ReLoading Scenario in JavaScript

- Evolve Scenarios
- Use Scenario to context the Data Analytics: R Studio, Python for computing

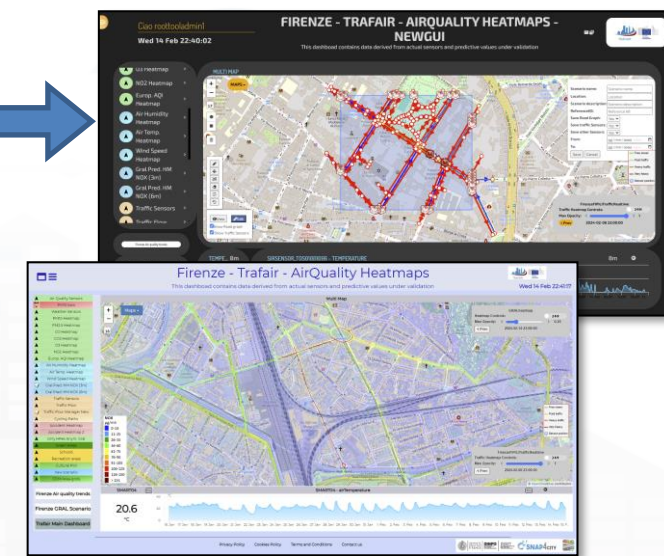



## Firenze - Trafair - AirQuality Heatmaps

This dashboard contains data derived from actual sensors and predictive values under validation



Wed 14 Feb 22:41:17

- ▲ Air Quality Sensors
- ▲ PM10 bars
- ▲ Weather Sensors
- ▲ PM10 Heatmap
- ▲ PM2.5 Heatmap
- ▲ CO Heatmap
- ▲ CO2 Heatmap
- ▲ O3 Heatmap
- ▲ NO2 Heatmap
- ▲ Europ. AQI Heatmap
- ▲ Air Humidity Heatmap
- ▲ Air Temp. Heatmap
- ▲ Wind Speed Heatmap
- ▲ Gral Pred. HM NOX (3m)
- ▲ Gral Pred. HM NOX (6m)
- ▲ Traffic Sensors
- ▲ Traffic Flow
- ▲ Traffic Flow Manager New
- ▲ Cycling Paths
- ▲ Accident Heatmap
- ▲ Accident Heatmap 2
- ▲ Only HRes Anym. Gral
- ▲ Green Areas
- ▲ Schools
- ▲ Recreation areas
- ▲ Cultural POI
- ▲ new scenario
- ▲ ODM Area-grids

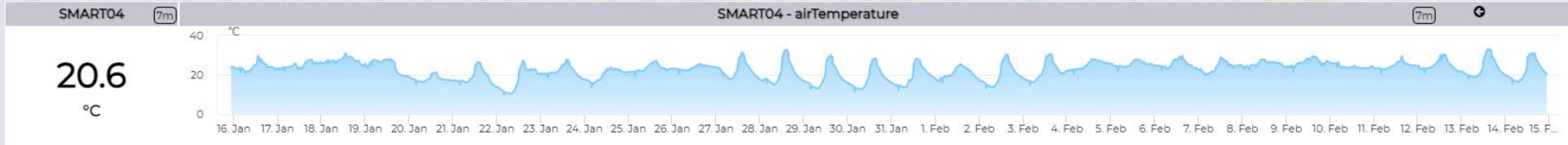

Firenze Air quality trends

Firenze GRAL Scenario

Trafair Main Dashboard

TOP

# *Data Analytics on Cloud: Snap4City Infrastructures*



# Data Analytics on Snap4City platform



Swagger

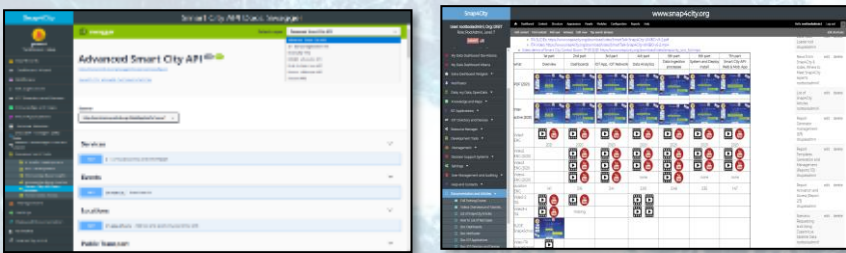

Ontology Schema



LOG.disit.org



Smart City API from Knowledge Base and other tools

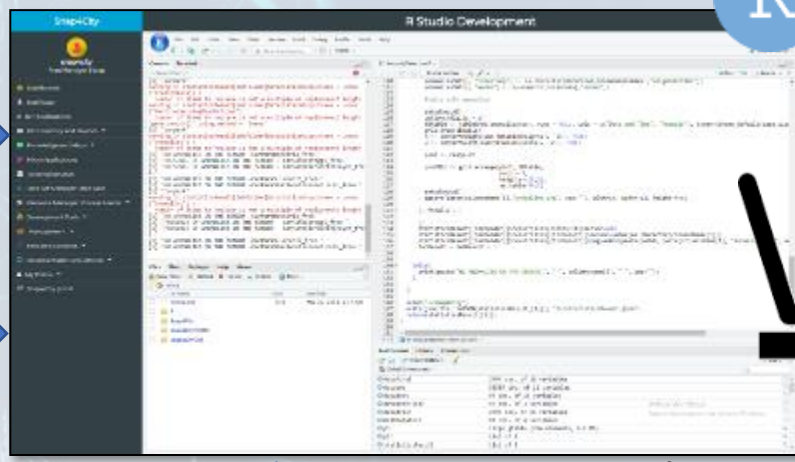

Creating MicroServices



Saving / Sharing reusing

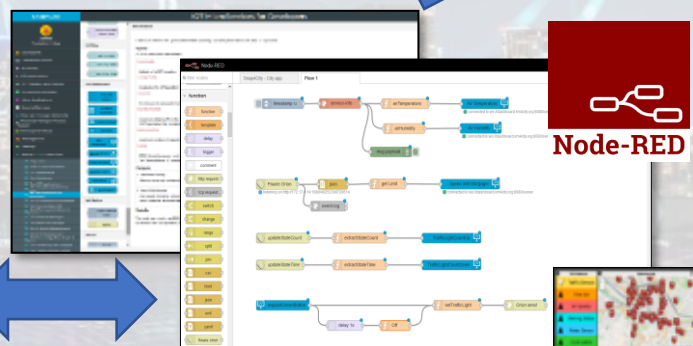

Resource Manager

Using them into IOT Applications

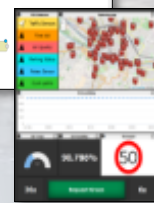

# Development

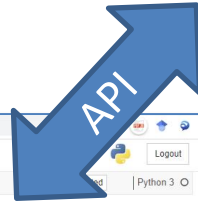
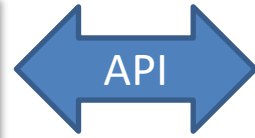
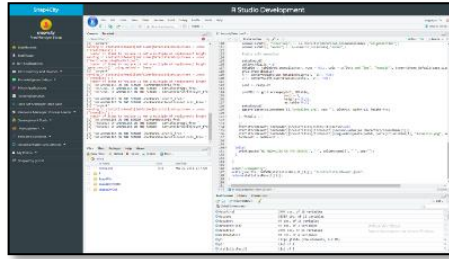

On Server  
Or  
On PC

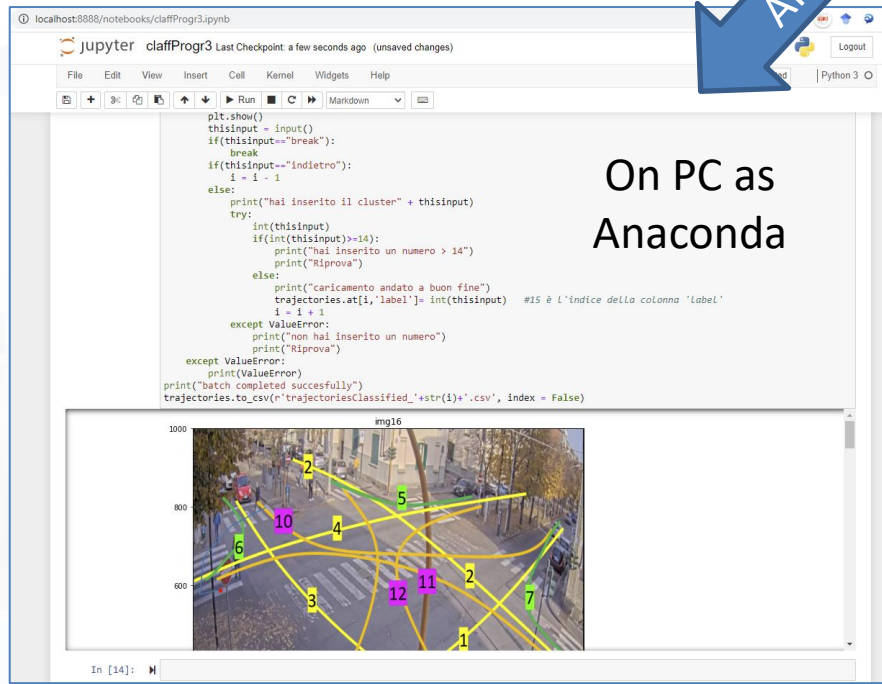

On PC as  
Anaconda



File.py  
AI Model  
Mapping  
Data..

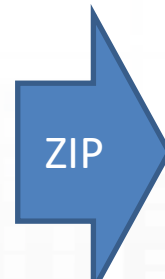

Load  
File.py  
or .zip

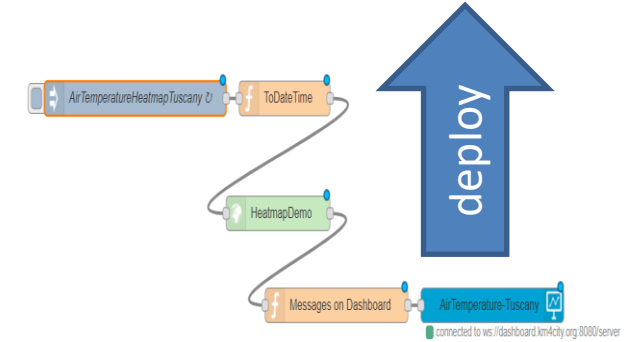
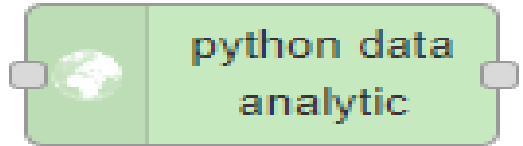

To make the .PY usable as MicroService you need to adapt it to get and send data in/out with Node-RED from a Container.  
**If you provide a .zip file the main .py inside has to be called doScript.py**



# Data Analytic Container



2

Open an Advanced IoT App / Node-RED

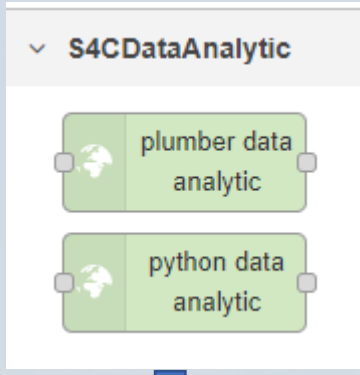

3

Use Snap4City Data Analytic Node, and load in the code you developed

1

Develop .py or .r program on (i) Snap4City platform online, or (ii) your Development Machine.

The code has to respect the guidelines provided. For example see:

- <https://www.snap4city.org/641>
- <https://www.snap4city.org/645>

4

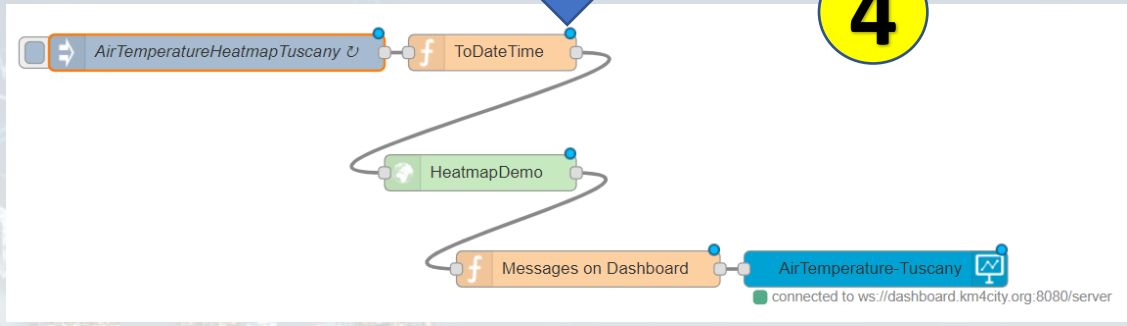

5

Deploy the IoT App → Snap4City Container Manager based on Marathon/Mesos is creating a Container for your Data Analytic code

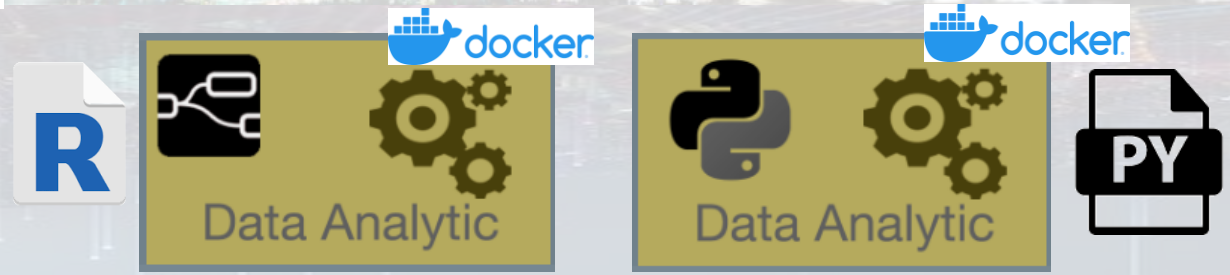



# *analytics example*



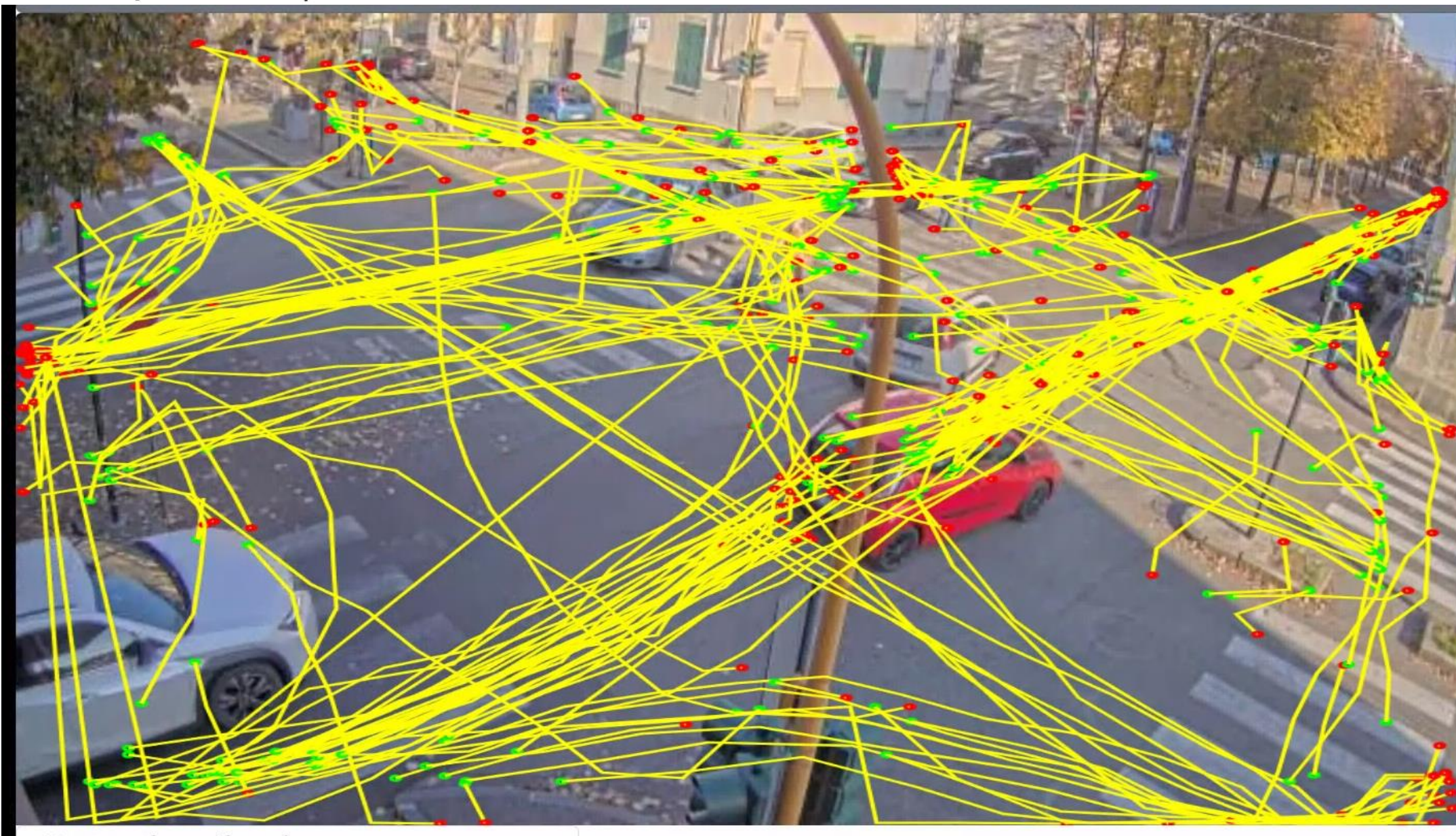



IoT edge on  
TV Camera

1

Send data to Broker

2

Device: CrossVenaria2  
with trajectories

IOT Broker

3

Save data

Big Data  
Store  
Facility

show data

4

Data Inspector

The Data Inspector interface displays a map of a city area with a red trajectory line. A data table is shown below the map, listing various data points for the device 'CROSSVENARIA2'. The table includes columns for Description, Value, and Last Update. A time-series graph at the bottom shows the 'dist' variable over a 4-hour period, with a peak value of 15.9.

| Description | Value | Last 1.7 days | Last 4 hours | Last 24 hours | Last 7 days | Last 30 days | Last 90 days |
|-------------|-------|---------------|--------------|---------------|-------------|--------------|--------------|
| dist        | 13.7  | Last Value    | Last Value   | Last Value    | Last Value  | Last Value   | Last Value   |



IoT edge on  
TV Camera



Send Trajectories

Send data to Broker

**IOT Broker**

**Devices:**

- CrossVenaria2VehicleFlowTrajectoriesV2
- VenariaConteggio



**e**

Send data to Broker

**f**

Save data

Save Counting per Cluster

**Big Data Store Facility**

Get data

**c**

**Device:**  
CrossVenaria2  
with  
trajectories

Periodically

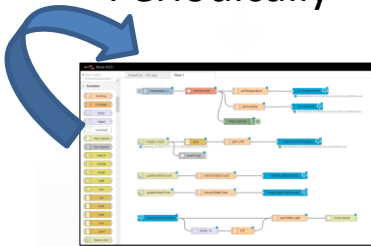

**b**

Activate



**d**

From Trajectories  
to clusters.  
Counting in/out  
and flows

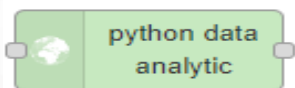

**a**

show data

**g**

Create and use a Dashboard

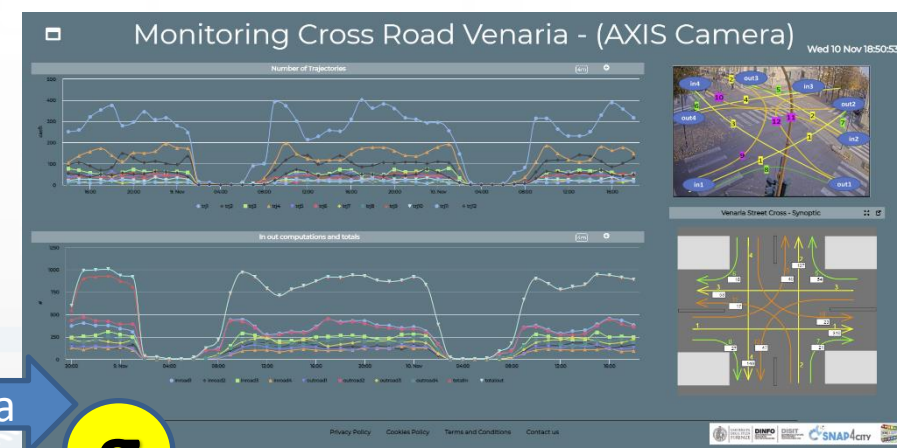

## Traffic Flow Analysis via TV Camera and Clustering on cloud



### Monitoring Cross Road Venaria - (AXIS Camera)

Wed 10 Nov 18:00

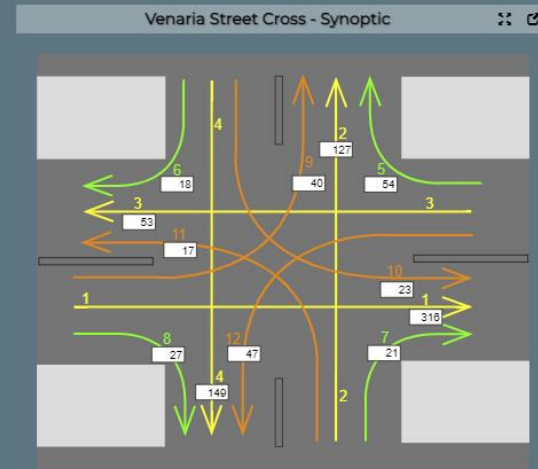
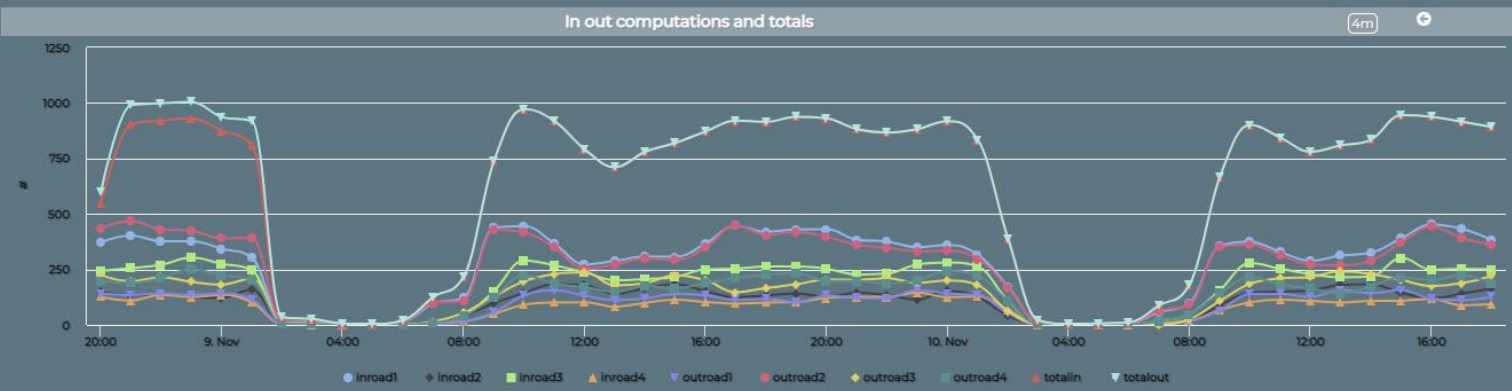
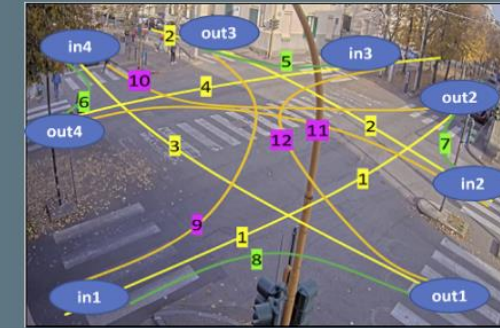
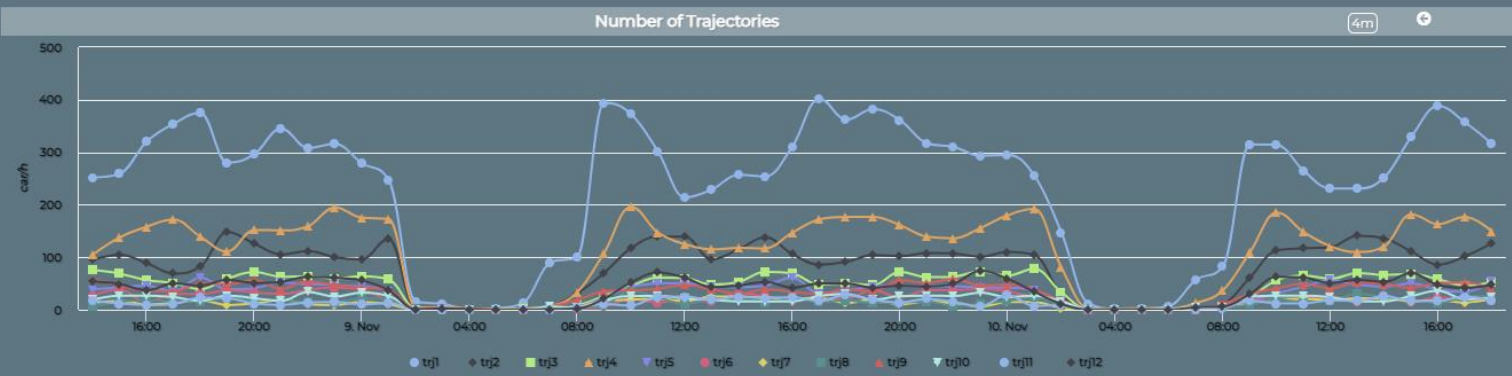

# Managing TV Cam

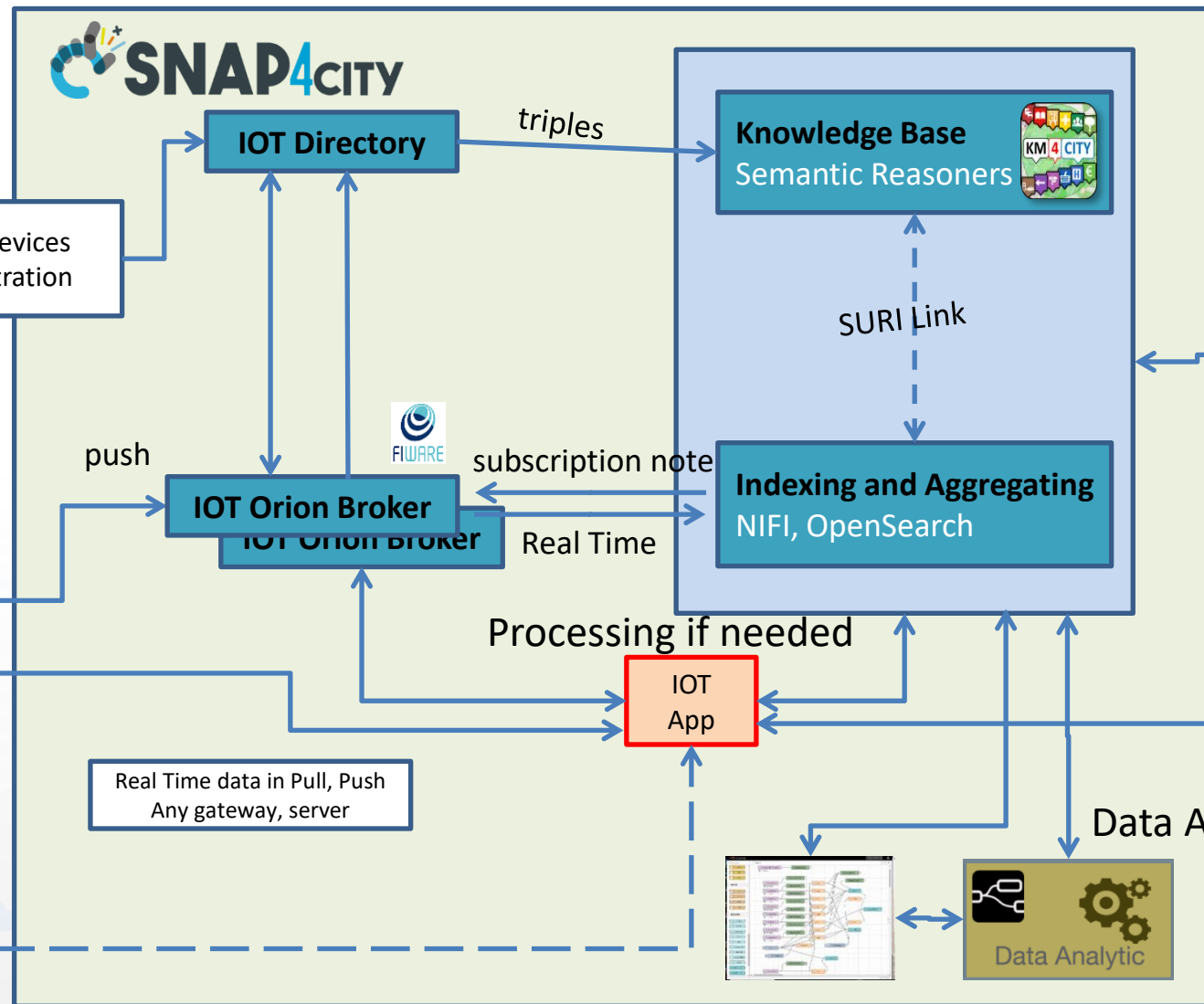

# *Data Analytics on Dedicated Computer or HPC*



# Data Analytics on Snap4City platform



Swagger

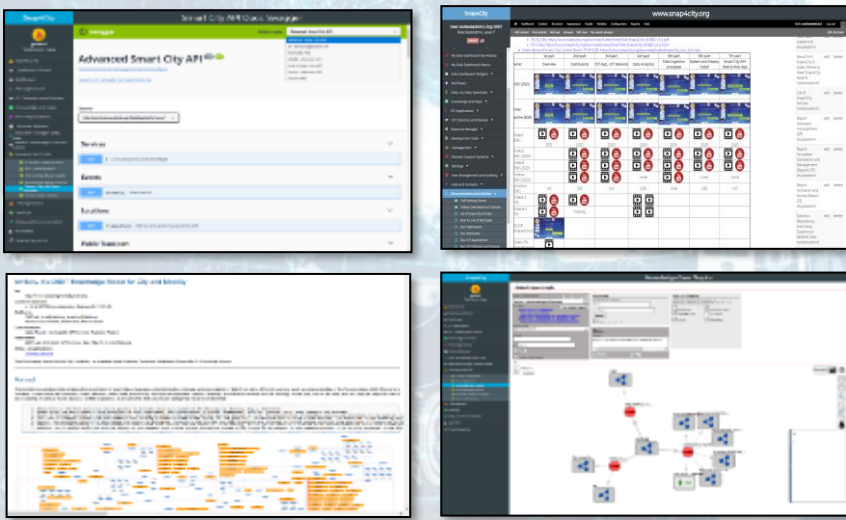

Ontology Schema

LOG.disit.org



Smart City API from Knowledge Base and other tools

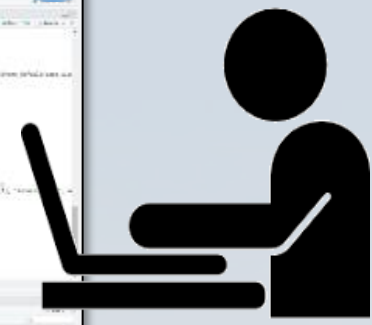
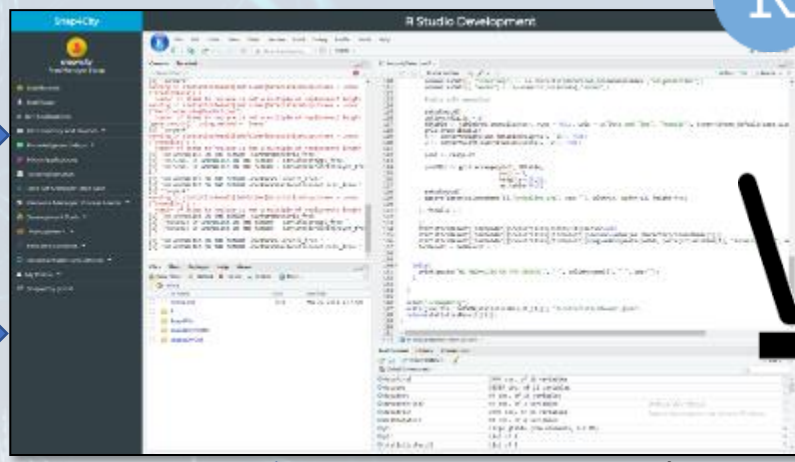

Saving / Sharing reusing



Resource Manager





# Development

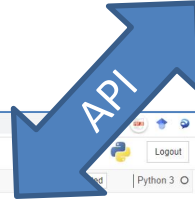
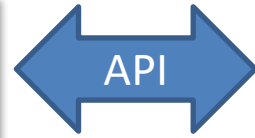
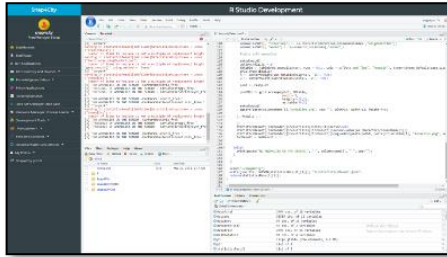

## EXECUTION



On Server  
Or  
On PC

On PC as Local Environment

DEVELOPMENT

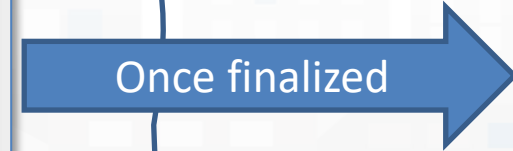

Process: file .R or .Py (+ the AI/ML model, data) can be put in execution with local scheduler or Cron

TOP

# *DP, for DA, AI, XAI on Container RStudio*



# Rstudio

The screenshot displays the R Studio Development 0.11 interface within a web browser. The browser address bar shows the URL: `snap4city.org/dashboardSmartCity/management/iframeApp.php?linkUrl=https%3A%2F%2Frstudio1.snap4city.org%2Fauth-sign-in&pageTitle=R%20Studio%20Development%200.11...`

**Left Panel (Navigation):** Snap4City logo, user information (User: ipsaro.palesi, Org: DISIT, Role: AreaManager, Level: 2), and a sidebar menu with "Development Tools" and "R Studio Development 0.11" highlighted.

**Top Panel (R Studio):** R logo, menu bar (File, Edit, Code, View, Plots, Session, Build, Debug, Profile, Tools, Help), and project information (Project: (None)).

**Console (R Console):** Contains R code for calculating medians across clusters and plotting the results. The code includes: `median(imputedData0[imputedData0$cluster == idcluster, 18:18]),` `median(imputedData0[imputedData0$cluster == idcluster, 19:19]),` `median(imputedData0[imputedData0$cluster == idcluster, 20:20]),` `median(imputedData0[imputedData0$cluster == idcluster, 21:21]),` `median(imputedData0[imputedData0$cluster == idcluster, 22:22]),` `median(imputedData0[imputedData0$cluster == idcluster, 23:23]),` `median(imputedData0[imputedData0$cluster == idcluster, 24:24]),` `median(imputedData0[imputedData0$cluster == idcluster, 25:25]),` `median(imputedData0[imputedData0$cluster == idcluster, 26:26]),` `median(imputedData0[imputedData0$cluster == idcluster, 27:27]),` `median(imputedData0[imputedData0$cluster == idcluster, 28:28]),` `median(imputedData0[imputedData0$cluster == idcluster, 29:29])` and `plot(y,x,main = paste("Cluster",idcluster),sub = paste("Festivo",median(imputedData0[imputedData0$cluster == idcluster, 5:5])),xlab = "HH", ylab = "nConn")`.

**Code Editor (Code editor):** Shows R code for a loop: `for(idcluster in 1:7) {` `imputedData0$cluster=km7$cluster` `table(imputedData0$cluster)` `plot(table(imputedData0$cluster))` `idcluster=6` `for(idcluster in 1:7) {` `y=c(0,1,2,3,4,5,6,7,8,9,10,11,12,13,14,15,16,17,18,19,20,21,22,23)` `x=c(median(imputedData0[imputedData0$cluster == idcluster, 6:6]),` `median(imputedData0[imputedData0$cluster == idcluster, 7:7]),` `median(imputedData0[imputedData0$cluster == idcluster, 8:8]),` `median(imputedData0[imputedData0$cluster == idcluster, 9:9]),` `median(imputedData0[imputedData0$cluster == idcluster, 10:10]),` `median(imputedData0[imputedData0$cluster == idcluster, 11:11]),` `median(imputedData0[imputedData0$cluster == idcluster, 12:12]),` `median(imputedData0[imputedData0$cluster == idcluster, 13:13])` `}`

**Environment (Workspace and history):** Lists objects in the global environment: `km_sil_scaled` (List of 9), `km_sil0` (List of 9), `km_sil0_scaled` (List of 9), `km13` (List of 9), `km7` (List of 9), `pam_elbow0` (List of 9), `pam_sil0` (List of 9), `scaledData` (Large matrix (558104 elements, 5.5 Mb)), `scaledData0` (Large matrix (474816 elements, 4.8 Mb)), `test` (19784 obs. of 26 variables).

**Plots (Plot and files):** A scatter plot titled "Cluster 6" showing `nConn` on the y-axis (0.0 to 2.0) and `HH Festivo 0` on the x-axis (0 to 20). The plot shows a cluster of points around `HH Festivo 0` values of 5 to 15 and `nConn` values of 1.0 to 2.0.

## R code

- Installing and loading R packages

```
install.packages("cluster")
```

From GitHub

```
install.packages("devtools")  
devtools::install_github("kassambara/factoextra")
```

- Getting help with functions in R

```
?kmeans
```

- Importing your data into R

```
# .csv file: Read comma (",")  
separated values  
my_data <-  
read.csv(file.choose())
```

TOP

# AI/ML Operation and Development

## ML Ops

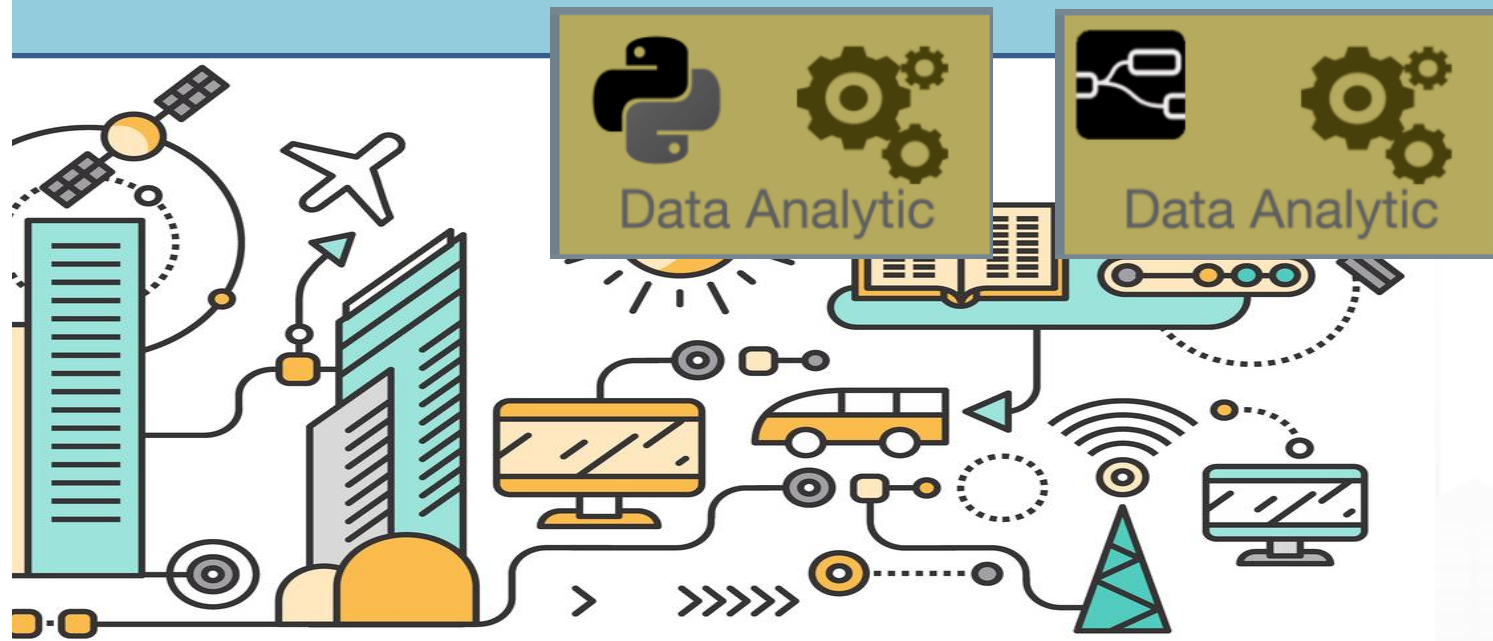
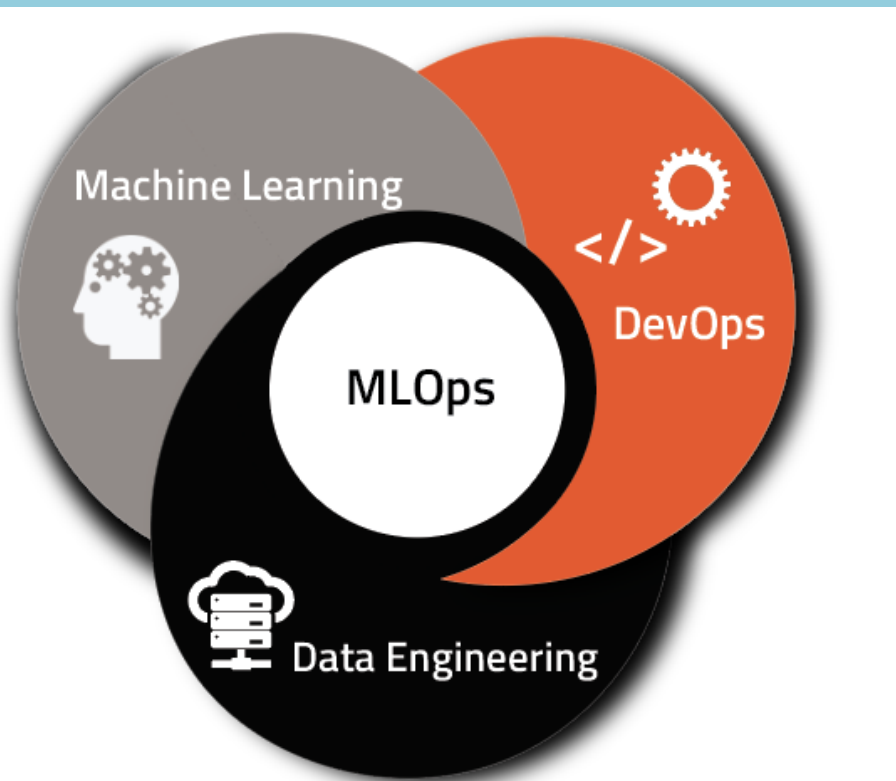

# Managing AI/ML operation/development: MLOps

- **Management of AI/ML processes:** training and execution
- **Training needs:** several processes
  - with different parameters and models to be trained, validated and test in batch to find the best results wrt metrics
  - High computational costs, time consuming if the processes have to be sent on GPU/CPU manually
- **Execution needs,** single executions in most cases singularly cheaper, but expensive for large volume of executions:
  - periodically as predictions (saving time if the model is loaded permanent)
  - on demand as optimisation, clustering, etc. (loading model, burning time)

# AI Training on Snap4City Infrastructure

- The training processes can be performed:
  - **On Jupyter HUB provided** by Snap4City in Python using ASCAPI, in this case the Jupyter HUB can be on CPU or CPU/GPU server
    - **By using ClearML** for the Training and/or Execution, on Cluster of GPU/CPU
      - Only Jupyter HUB of Snap4City can access to ClearML and Cluster of GPU/CPU
      - The access at ClearML facility has to be authorized by Snap4City Administrator
  - **On Jupyter HUB provided** by Snap4City in Python using ASCAPI, in this case the Jupyter HUB can be on CPU or CPU/GPU server
  - **On Jupyter HUB** in Python using ASCAPI, in this case the Jupyter HUB can be on CPU or CPU/GPU server, not provided by Snap4City, not accessing to CPU/GPU of Snap4City
  - **On your computer in Python** using ASCAPI, not accessing to on cloud CPU/GPU of Snap4City.



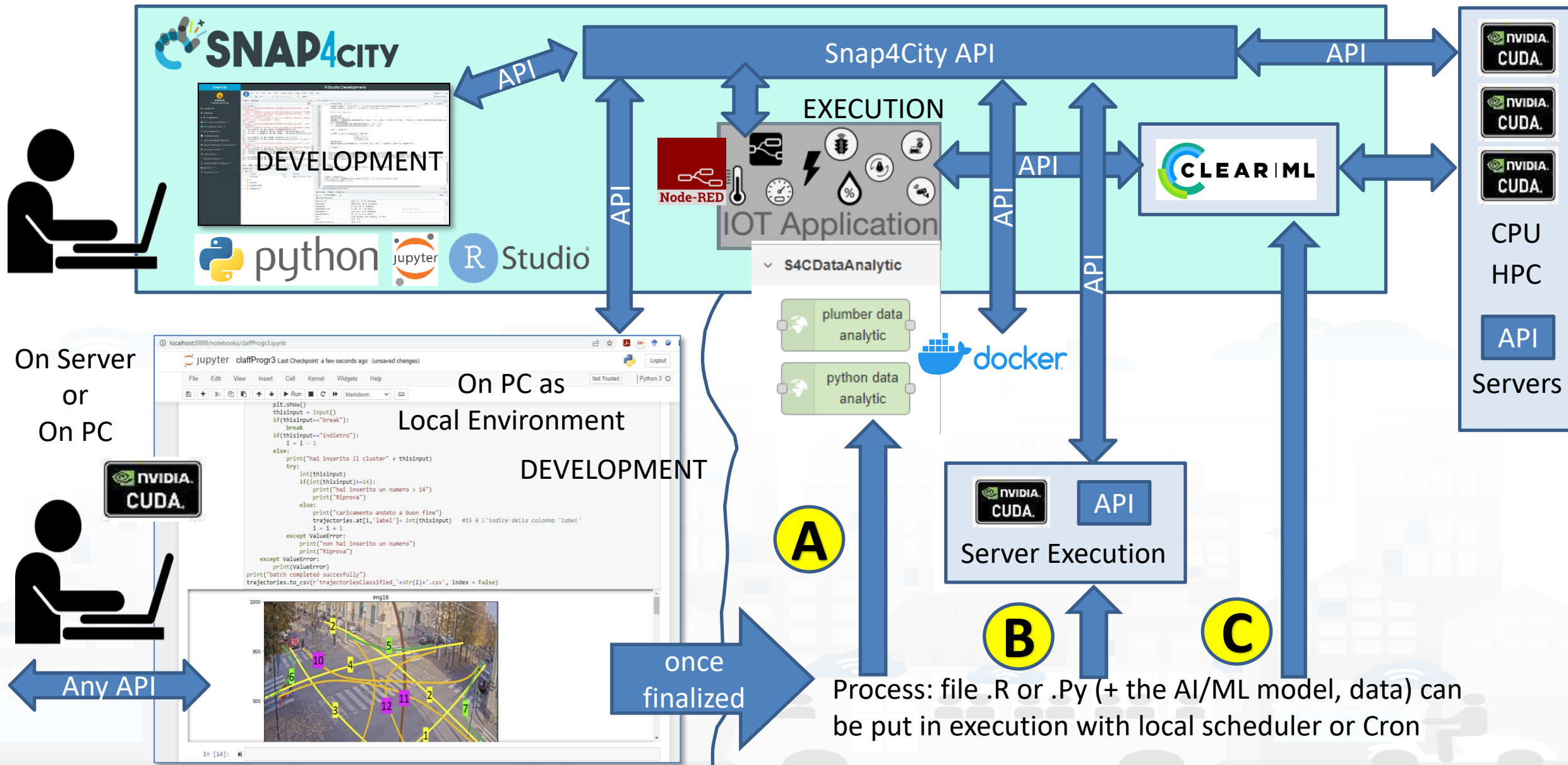

Process: file .R or .Py (+ the AI/ML model, data) can be put in execution with local scheduler or Cron



# MLOps Possibilities on Snap4City infrastructure

The developers can create their AI models using Snap4City data and infrastructure (Jupiter Hub):

- **1) to put them in execution** (they could develop the solution on their Computer as well)
  - A) on stable container on CPUs via Node-RED, Docker
  - B) on some server with GPU/CPU
- **2) using ClearML and to put them in execution** on a process managed by ClearML on some cluster of GPU/CPU
  - 2a) as stable process on ClearML managed Docker, via API (usable from Rest Calls as well as from Node-RED Snap4City MicroServices, from the platform)
  - 2b) as sporadic process ClearML managed, via API (usable from Rest Calls as well as from Node-RED Snap4City MicroServices, from the platform)





**PROJECTS**

RECENT ▾ Team's Work ▾ + NEW PROJECT

All Experiments DevOps prueba\_modelo prueba\_modelo\_pp

GP\_Fine-Tuning GP\_Inference GP\_Q2

GP\_D1 GP\_Test prueba

LOAD MORE

**WORKERS AND QUEUES**

WORKERS QUEUES

CPU and GPU Usage

Count

13 Jul 15 Jul 17 Jul 19 Jul 21 Jul 23 Jul 25 Jul 27 Jul 29 Jul 31 Jul 02 Aug 04 Aug 06 Aug

CLEARML

RECENTLY RUNNING EXPERIMENT : EXPERIMENT RUNNING TIME : ITERATION

Worker Name: 41-4090  
Experiment Run Time: a few seconds ago  
Update Time: a few seconds ago  
Current Experiment: select\_best\_model

**PROJECTS / All Experiments**

EXPERIMENTS MODELS

+ NEW EXPERIMENT OPEN ARCHIVE

Service serving183  
Service serving master  
Service serving182  
Inference Serving 61 CPU Only - serve instance  
Inference serving183 - serve instance  
Monitor serving master - statistics controller  
Inference Serving 61 CPU Only - triton engine  
Monitor Skype Alerts  
Monitor serving183 - statistics controller  
Inference serving master - serve instance  
Monitor Serving 61 CPU Only - statistics controller  
Inference Serving 61 CPU Only - triton engine  
Inference serving182 - serve instance

Demo User's workspace / PROJECTS / Hyperparameter Optimization

OVERVIEW EXPERIMENTS MODELS

epoch\_accuracy / epoch\_accuracy

epoch\_accuracy / validation\_epoch\_accuracy

epoch\_loss / epoch\_loss

epoch\_loss / validation\_epoch\_loss

**RECENT PROJECTS** VIEW ALL + NEW PROJECT

DevOps prueba\_modelo prueba\_modelo\_pp GP\_Fine-Tuning

104 4 0 15 0 0 6 0 0 32 0 0

TOTAL RUNNING COMPLETED (24 hrs) COMPUTE TIME: 74 DAYS 19:30:35 COMPUTE TIME: 1 DAY 00:24:26 COMPUTE TIME: 00:30:28 COMPUTE TIME: 01:22:34

RECENT EXPERIMENTS

| TYPE      | TITLE                                | PROJECT | STARTED           | UPDATED          | STATUS  |
|-----------|--------------------------------------|---------|-------------------|------------------|---------|
| Service   | serving183                           | DevOps  | Jun 6 2024 9:43   | Aug 7 2024 15:33 | Running |
| Service   | serving master                       | DevOps  | Jul 10 2024 12:01 | Aug 7 2024 15:33 | Running |
| Service   | serving182                           | DevOps  | Jun 6 2024 10:14  | Aug 7 2024 15:33 | Running |
| Service   | Serving 61 CPU Only                  | DevOps  | Jun 4 2024 17:20  | Aug 7 2024 15:18 | Running |
| Inference | Serving 61 CPU Only - serve instance | DevOps  | Jun 4 2024 17:22  | Aug 5 2024 11:47 | Aborted |

# ClearML Features

- **Experiment Tracking:** Provides advanced features for experiment tracking, including automatic logging of metrics, output, source code, and the execution environment. This ensures that each experiment is reproducible, and its results are easily shareable and comparable.
- **Data and Model Management:** Provides tools for efficient management of datasets and models, allowing for easy versioning, archiving, and sharing. Users can track model versions and easily associate them with corresponding experiments.
- **Integration and Compatibility:** ClearML is designed to integrate with existing development environments and tools, such as **Jupyter Notebooks, TensorFlow, PyTorch, and many others**, thus supporting a wide variety of workflows and technology stacks.
- **User Interface and Dashboard:** offers an intuitive dashboard that allows users to monitor the status of experiments in real time, view metrics and outputs, and manage resources and execution queues, all from a single interface.
- **Automation and Orchestration:** It allows the remote execution of experiments on any machine and distributes the tasks to be executed according to a system of queues and priorities. Also automating Hyper-parametrization via **Optuna**

TOP

# Design & Develop: user interfaces, visual tools

Part 2  
Part 3



# Development Life Cycle Smart Solutions

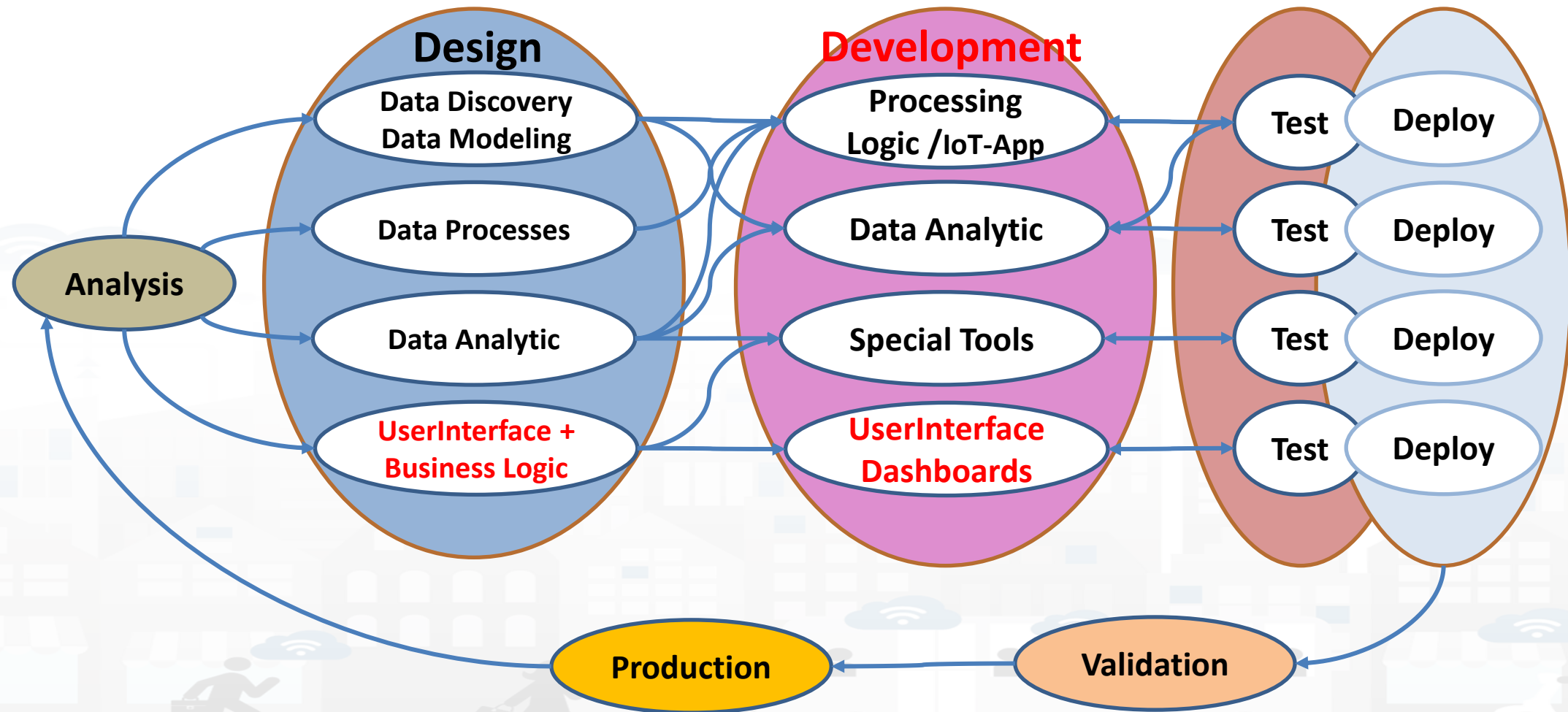

# Snap4City Tools

vs

# Development Life Cycle

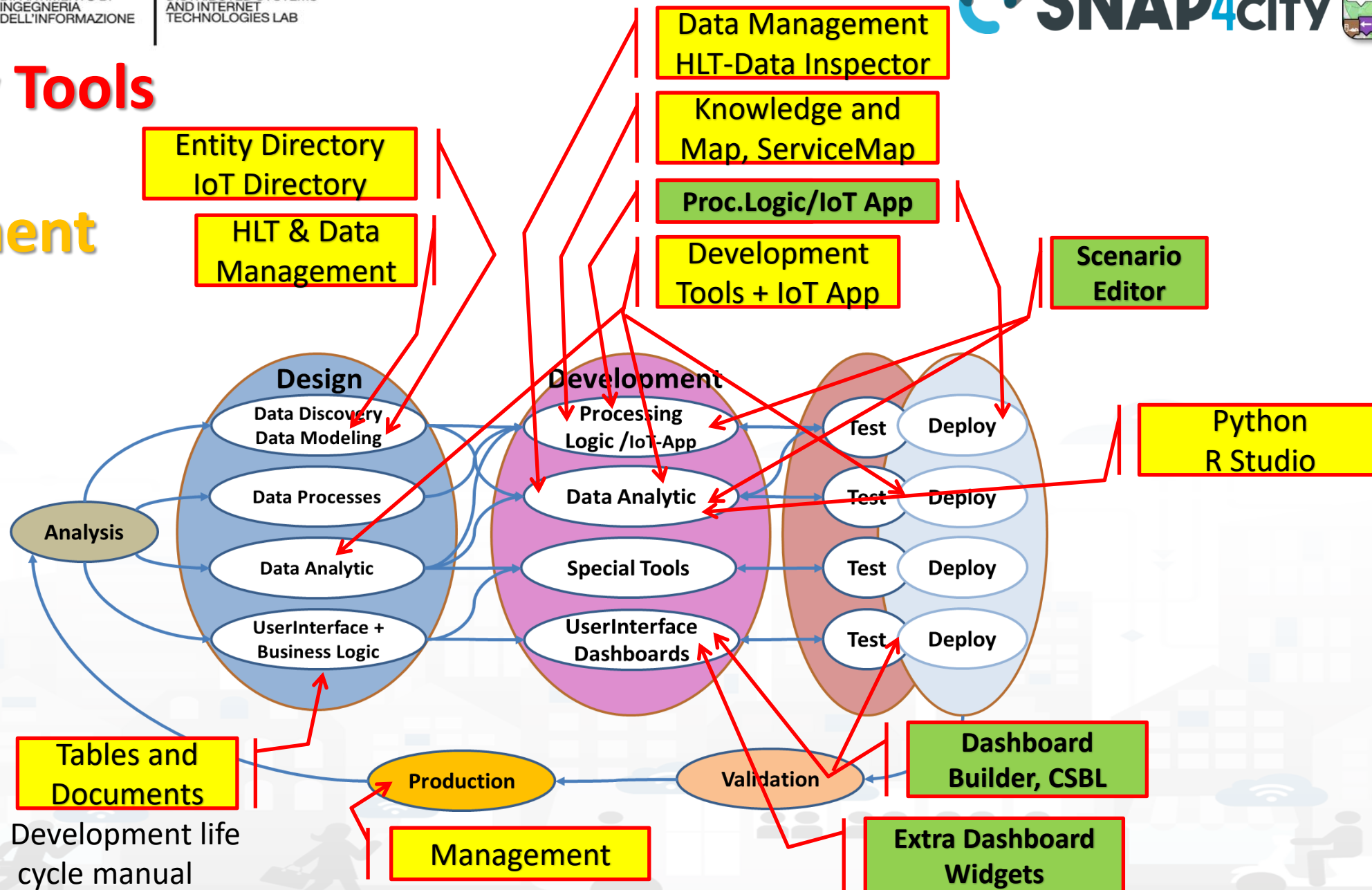

# Technical Architecture

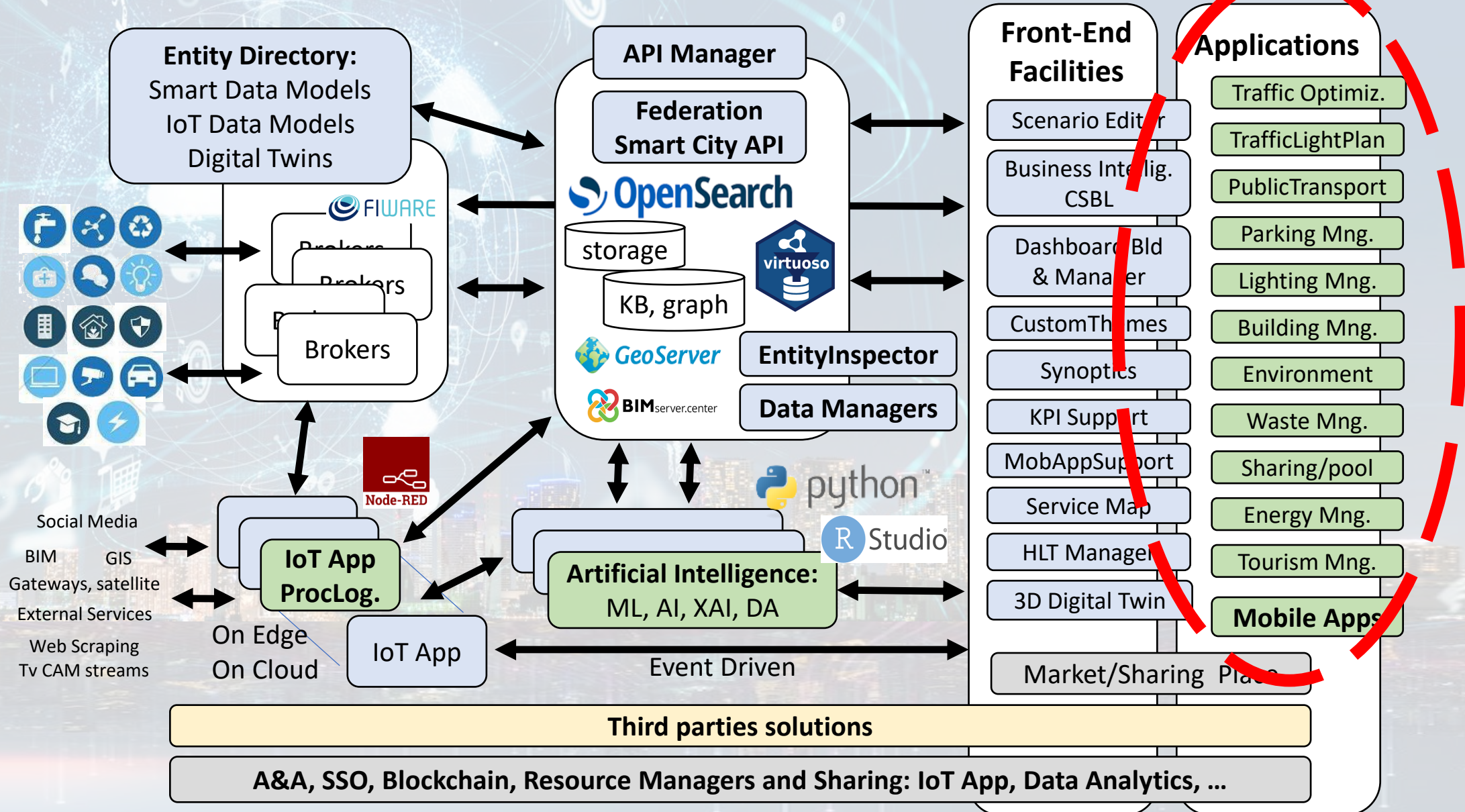



# Snap4City Dashboard Builder (2023) vs Kibana/Grafana

| Features                                                                                                     | Snap4City Dashboard Builder    | Kibana, Grafana |
|--------------------------------------------------------------------------------------------------------------|--------------------------------|-----------------|
| Large Collection of Widgets, also from D3 library                                                            | YES                            | Nothing         |
| Custom Widgets SVG of any kind, full defined process for customization                                       | YES                            | Nothing         |
| Real time event driven widgets and data                                                                      | YES                            | Nothing         |
| Server/Client Side Business Logic for data transformation with visual programming: Node-RED                  | YES: visual/coding             | coding          |
| Maps with custom PIN, bubbles, animated and moving, etc.                                                     | YES                            | Nothing         |
| Maps with paths, shapes, traffic flow, scenarios, routing, heatmaps, what-if, Origin Destination Matrix, ... | YES                            | Nothing         |
| Maps with Orthomaps from WFS, WMS, GIS connection, etc.                                                      | YES                            | Nothing         |
| TV camera integration and selection                                                                          | YES                            | Nothing         |
| Widgets for business logic integration on real time: buttons, selector, switch, etc.                         | YES                            | Nothing         |
| Kiviat, Spider net, Calendar (also any other D3 Widgets)                                                     | YES                            | Nothing         |
| Typical Time Trends: day hours, month week, month days, ....                                                 | YES                            | Nothing         |
| Time Trend Compare: day, week, month, year                                                                   | YES                            | Nothing         |
| Selectors/Menus: text, icons, etc., also in connection with IOT APP, Node-RED                                | YES                            | Nothing         |
| Full control of graphic layout, font, colours, refresh per widget, etc.                                      | YES                            | Nothing         |
| Iframe integration of third party widgets and web pages, nesting dashboards, embedding Kibana                | YES                            | Nothing         |
| Connection among multiple Dashboards and Widgets                                                             | YES                            | Nothing         |
| Synchronization with Video Wall, and Operators Views                                                         | YES                            | Nothing         |
| Multiseries, bar lines, charts, pie, donut, simple selectors, trends, etc., also from business logic         | YES                            | Limited         |
| Single content, string, html, any data, etc.                                                                 | YES                            | Limited         |
| Special widgets: Weather forecast, civil protection, road plates, Twitter, SVG, etc...                       | YES                            | Nothing         |
| Digital Twin Local (BIM) and Global (3D city representation) with 3D traffic, Heatmaps, Devices, ...         | YES                            | Nothing         |
| Faceted search                                                                                               | YES: selectors, forms, buttons | YES             |



# High Level Types

Snap4City (C), Sept. 2024

- POI, IOT Devices, shapes, ...
  - FIWARE Smart Data Models,
  - IoT Device Models
- GIS, maps, orthomaps, WFS/WMS, GeoTiff, calibrated heatmaps, ..
- Satellite data, ..
- traffic flow, typical trends, ..
- trajectories, events, Workflow, ..
- 3D Models, BIM, Digital Twins, ..
- OD Matrices of several kinds, ..
- Dynamic icons/pins, ..
- Synoptics, animations, ..
- KPI, personal KPI, ..
- social media data, TV Stream,
- routing, multimodal, constraints, ..
- decision scenarios, ....
- etc.

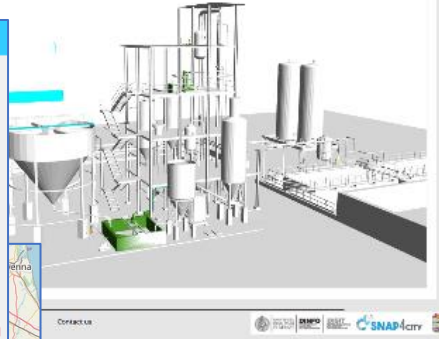
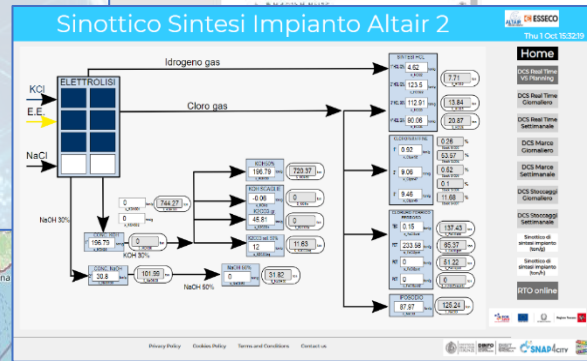
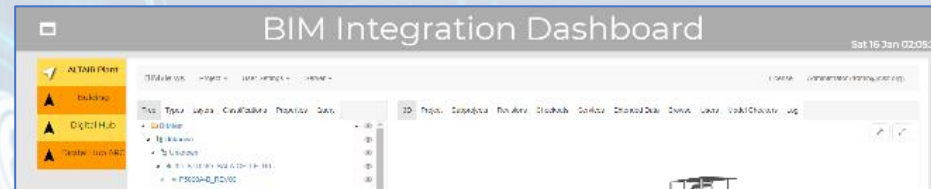

**SNAP4CITY**  
- Digital Twin Global - Fire  
demonstrator

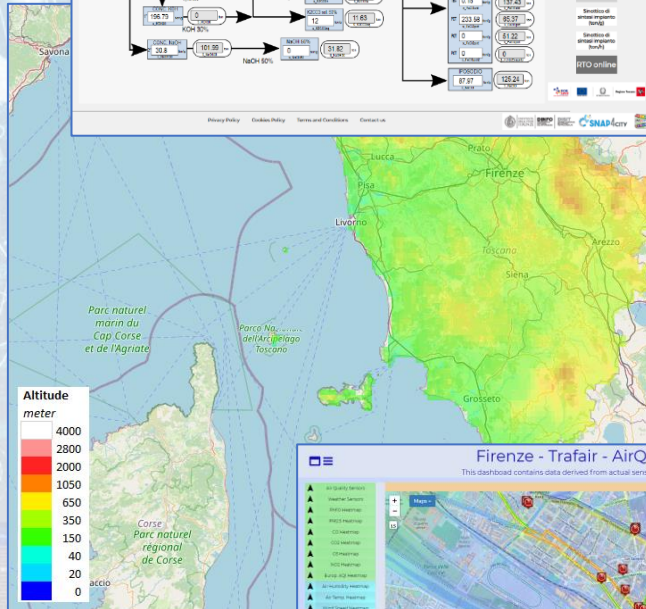

UNIVERSITÀ  
DEGLI STUDI  
FIRENZE

**DINFO**  
DIPARTIMENTO DI  
INGEGNERIA  
DELL'INFORMAZIONE

**DISIT**  
DISTRIBUTED SYSTEMS  
AND INTERNET  
TECHNOLOGIES LAB



# Different Themes

Firenze - Trafair - AirQuality Heatmaps

This dashboard contains data derived from actual sensors and predictive values under validation

Sun 25 Oct 18:52:00

Multi Map

IBIMET\_SMART09 - air/temperature

18.6 °C

Firenze Air quality trends

Trafair Main Dashboard

Legacy

Ciao rootloodadmin!

FIRENZE - TRAFAIR - AIRQUALITY HEATMAPS - NEWGUI

This dashboard contains data derived from actual sensors and predictive values under validation

Tue 3 May 20:42:51

MULTI MAP

IBIMET\_9m

20.6 °C

IBIMET\_SMART09 - AIRTEMPERATURE

9m

BaloonDark Part 2

Ciao rootloodadmin!

3D MULTI DATA MAP - DIGITAL TWIN GLOBAL - FIRENZE - NEWGUI

Tue 3 May 14:31:42

METRO8\_9m

240

METRO8 - VEHICLEFLOW

9m

Baloon

Ciao rootloodadmin!

Traffic Flow Manager On Multiple Cities - Newgui

Wed 8 Jun 23:22:04

METRO88 - AverageSpeed

9m

Geo

Dashboards (Public)

- www.snap4solutions.org
- Extra Dashboard Widgets
- Data Management, HLT
- Knowledge and Maps
- Processing Logics / IOT App
- Entity Directory and Devices
- Resource Manager
- Development Tools
- Management
- Decision Support Systems
- Deploy and Installation
- Help and Contacts
- Documentation and Articles
- Km4City portal



Prev 1 ... 34 35 36 37 38 Next

Filter by dashboard

Part 2

**Traffic Flow Manager test**  
Passive  
Public (DISIT)

**Traffic Flow Monitoring - Firenze - Cloned2**  
Passive  
Public (Firenze)

**D3 library -- newgui2**  
Proc.Logic / IoT App  
Public (DISIT)

**Traffic Flow Reconstruction - Sii-Mobility**  
Passive  
Public (Other)

**Traffic Flow Reconstruction for the cities**  
Passive  
Public (Other)

**3D Map Global Digital Twin -newgui2**  
Passive  
Public (DISIT)

**3D Multi Data Map - Digital Twin Global - Firenze**  
Passive  
Public (DISIT)

**Trends transparencies - newgui**  
Passive  
Public (DISIT)

**Tuscany TRAFAIR Data Dashboard**  
Passive  
Public (DISIT)

**Tuscany weather dashboard 1**  
Passive  
Public (DISIT)

# Dashboard List and Editor

Part 2

### Snap4City

User: roottooladmin1, Org: none  
Role: RootAdmin, Level: 7

- Dashboards**
- My Dashboards
- Notificator
- IOT Applications
- My Personal Data
- IOT Directory and Devices
- Knowledge and Maps
- Micro Applications
- External Services
- Data Set Manager: Data Gate
- Resource Manager: Process Loader
- Development Tools
- Management
- Settings
- User Management and Auditing
- Help and Contacts
- Documentation and Articles
- My Profile
- Snap4City portal
- Km4City portal
- DISIT Lab portal

### Dashboards

Cards [A-Z] [Z-A] [Filter] [Refresh]

Prev 1 2 Next

data [Search] [Close]

New dashboard

#### DataCenter

Passive

disit: Public

Edit Management Clone Delete

#### Datacenter Energy Consumption

Passive

disit: Public

Edit Management Clone Delete

#### DataCenter gas and smoke (desktop)

Passive

disit: Public

Edit Management Clone Delete

#### DataCenter gas and smoke (mobile)

Passive

disit: Public

Edit Management Clone Delete

#### FirenzeWiFi

Passive

disit: Private

Edit Management Clone Delete

#### Florence data overview

Passive

disit: Public

Edit Management Clone Delete

#### Leonardo - Smart city data 2

Passive

Leonardo: Public

Edit Management Clone Delete

#### My data and trends

Passive

nicola.mitolo: Public

Edit Management Clone Delete

#### My data trends

Passive

nicola.mitolo: Public

Edit Management Clone Delete

#### Notificator monitoring

Passive

disit: Public

Edit Management Clone Delete

#### Pisa Real Time Data

Passive

mitolo: Public

Edit Management Clone Delete

#### Real Time Sensors via ServiceMap3D

Passive

disit: Public

Edit Management Clone Delete



# How the Dashboards exchange data

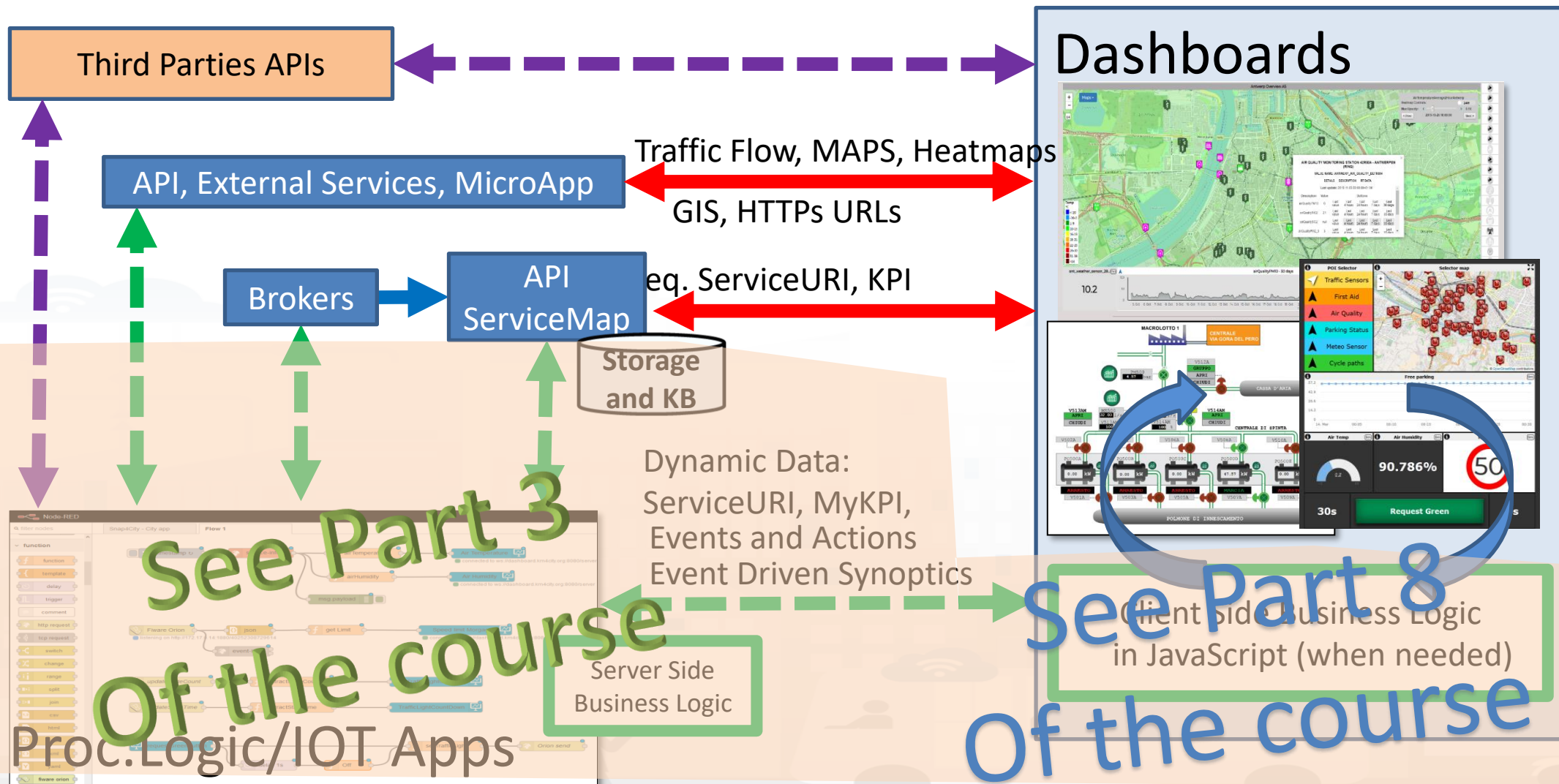

# Dashboard List and Editor

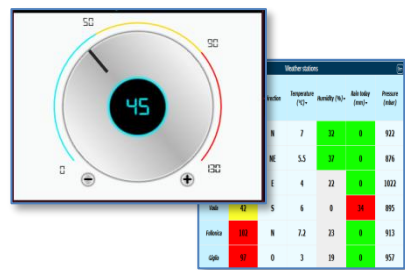

| CRID              | 2018-000530                    | S.P.N. 73 DI MALLMANTILE - ISTITUZIONE | TEMPORARY TRAFFIC LIGHTS |
|-------------------|--------------------------------|----------------------------------------|--------------------------|
|                   | 16/03/2018                     | 00:00:00                               | 5                        |
| CRID: 2018-000531 | S.P.N. 105 DI TORRANCIPOLITANO | TEMPORARY TRAFFIC LIGHTS               |                          |
|                   | 12/03/2018                     | 00:00:00                               | 5                        |

**INCIDENTI SOLO DANNI**

| AGGIUNTA(S)                 | 11/03/2018                                                   | 10:06:12   | 1        |   |
|-----------------------------|--------------------------------------------------------------|------------|----------|---|
| <b>INCIDENTI CON FERITI</b> | AGGIUNTA(S) <td>11/03/2018</td> <td>05:30:23</td> <td>1</td> | 11/03/2018 | 05:30:23 | 1 |
| <b>INCIDENTI SOLO DANNI</b> | AGGIUNTA(S) <td>11/03/2018</td> <td>05:58:48</td> <td>1</td> | 11/03/2018 | 05:58:48 | 1 |
| <b>INCIDENTI CON FERITI</b> | AGGIUNTA(S) <td>11/03/2018</td> <td>05:38:41</td> <td>1</td> | 11/03/2018 | 05:38:41 | 1 |



Cam Firenze 1, Cam Firenze 2

Antwerp Helsinki Florence Current Blue

PeopleNumber

|   |   |        |
|---|---|--------|
| 7 | 8 | 9      |
| 4 | 5 | 6      |
| 1 | 2 | 3      |
| 0 | . | Cancel |

Confirm

Green Yellow Red

122770 kWh

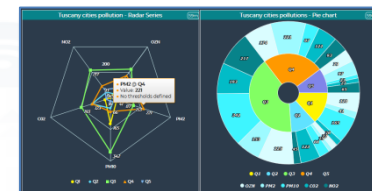

Snap4City - Mobility Operator

5.1

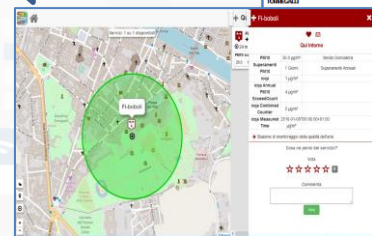

Europa Montepagni

Lavagnini Statuto

45 45

45 45

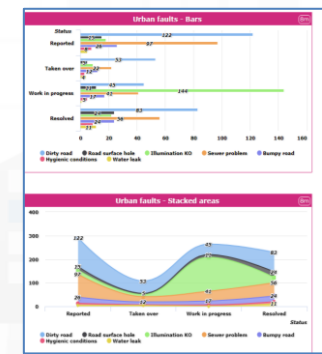
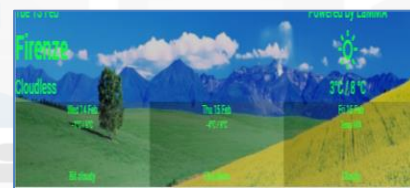



# The Selector for Multi Data Maps

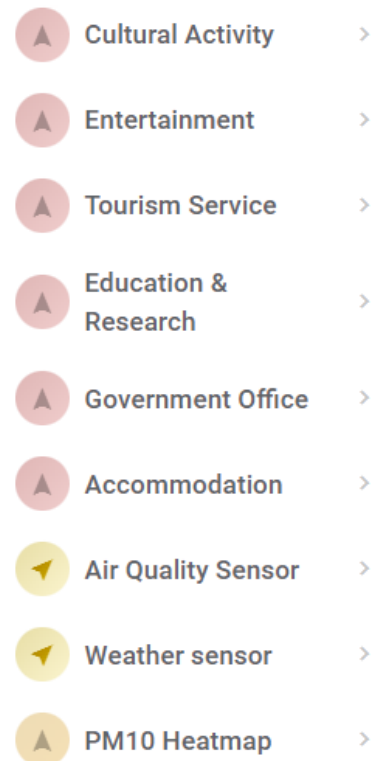
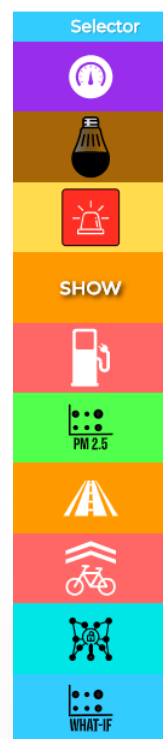
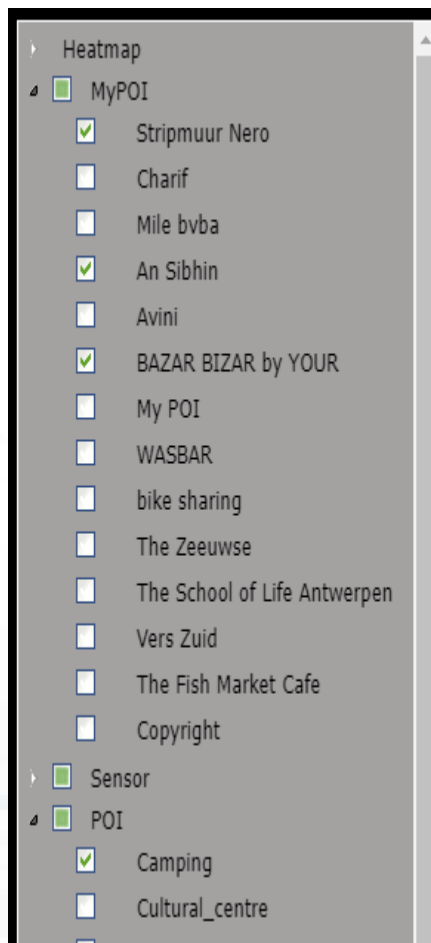

- **Different styles**
  - Icon and Text menu
  - Custom Menu Icon
  - Icon Menu buttons
  - Etc.
- **Features**
  - Removable header
  - Colours custom
  - Transparencies
  - Mixed modalities
- **Note:**
  - Manus can be realized also with a set of Buttons

*The Selector is the Map Controller*

# Custom Dynamic Pins

EDITING

Properties

Selector

- Hide header
- Hide dim ctrl
- Header color
- Title color
- Background color
- Border color
- More options**
- Delete widget
- Quit

Custom Pins on Map - test GP

Sat 31 Oct 11:35:41

Multi Data Map

METRO19 - averageSpeed

0.1 Km/h

Privacy Policy Cookies Policy Terms and Conditions Contact us

<https://www.snap4city.org/dashboardSmartCity/view/index.php?iddashboard=Mjk5MA==>

# The Selector is the Map Controller

## Custom Pins on Map - test GP

No subtitle

Sat 31 O

Properties Wizard Add widget Separator Embedding Screenshot Save Preview

MoreOptions

Pin Icon: Pin Icon

| Data widgets     | Default View Mode | Map Icon color | Alternate View Mode |
|------------------|-------------------|----------------|---------------------|
| Nothing selected |                   |                | Bub                 |
| METRO19          | Pir               |                | Cus                 |
| METRO19          | Pir               |                | Cus                 |
| METRO19          | Pir               |                | Cus                 |
| METRO19          |                   | Symbol         | Cus                 |
| Nothing selected |                   |                |                     |
| Nothing selected |                   |                |                     |
| Nothing selected |                   |                |                     |
| Nothing selected |                   |                |                     |
| Nothing selected |                   |                |                     |
| Nothing selected |                   |                |                     |

• Targeting the data to be shows on other data Widgets

Selector - Map

| PSVG3B             |         |             |              |               |             |  |
|--------------------|---------|-------------|--------------|---------------|-------------|--|
| VALUE NAME: PSVG3B |         |             |              |               |             |  |
|                    | DETAILS | DESCRIPTION | RT DATA      |               |             |  |
| str1               | eccolo  | Last value  | Last 4 hours | Last 24 hours | Last 7 days |  |
| val1               | 0       | Last value  | Last 4 hours | Last 24 hours | Last 7 days |  |
| val2               | 2       | Last value  | Last 4 hours | Last 24 hours | Last 7 days |  |
| val3               | 34      | Last value  | Last 4 hours | Last 24 hours | Last 7 days |  |
| val4               | 4       | Last value  | Last 4 hours | Last 24 hours | Last 7 days |  |

0.1 Km/h

TOP

# *Develop Dashboard*

## *Main Concepts*



# Snap4City Dashboards main concepts

Header

Dashboard

Interactive Widgets

## Server Communication

- Real Time data requests/send
- Event Driven
- Server Side Business Logic
  - See Part 3 of the course

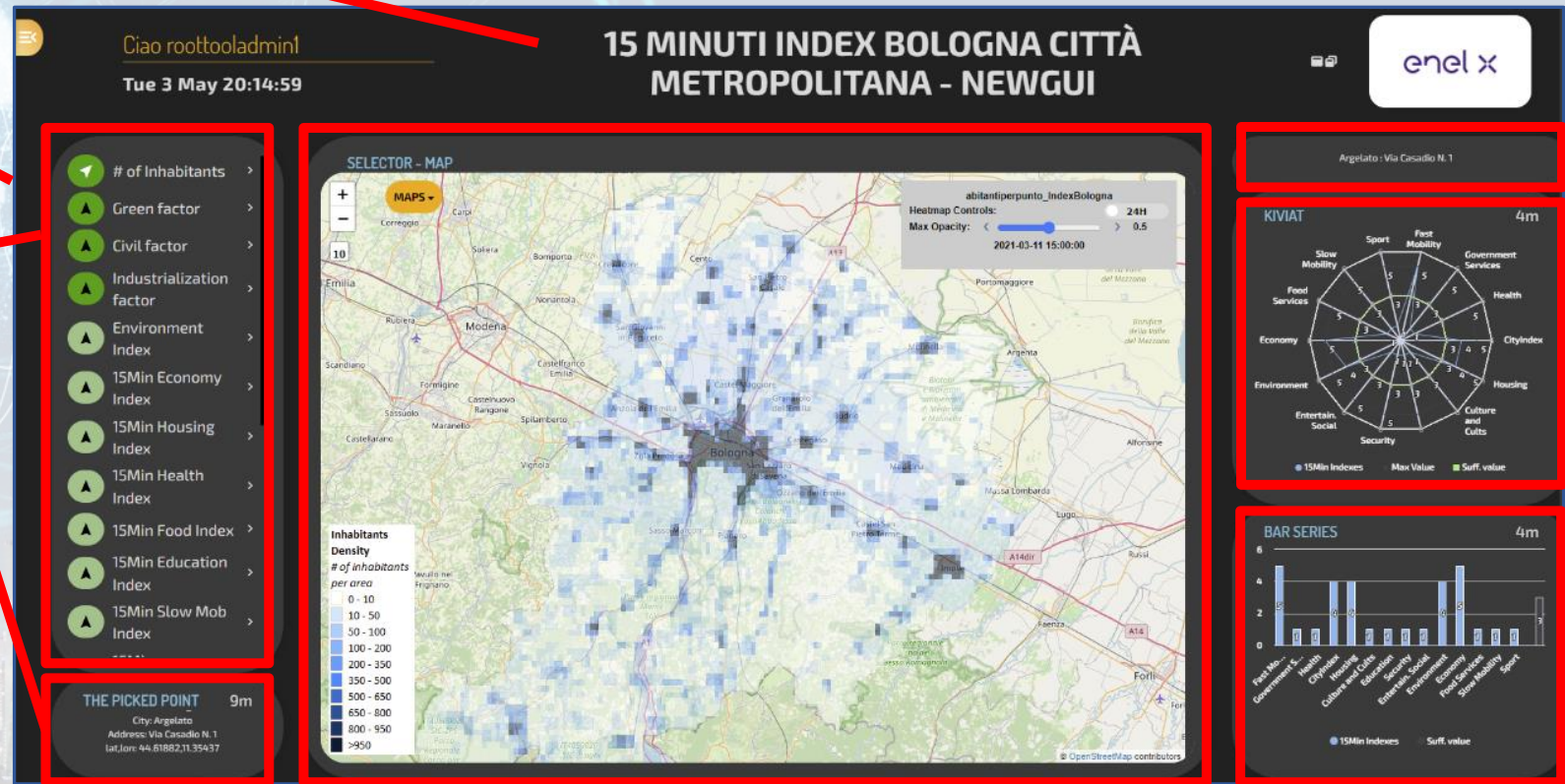

Inter Widget Communication:  
Client Side Business Logic  
See part 8 of the Course

# A Dashboard Design Schema is provided

In the following section, the schema that should be adopted to design each single Dashboard/view of the solution.

### IV.B.7. Example of Dashboard Schema

For each Dashboard or View we suggest to specify:

|                       |                                                                                                                                                                                                                                                                                                                                                                                                                                                                                                                                                                                                                                                                                                                                                                                                                                                                                                                                                                                                                                                                                                                                                              |
|-----------------------|--------------------------------------------------------------------------------------------------------------------------------------------------------------------------------------------------------------------------------------------------------------------------------------------------------------------------------------------------------------------------------------------------------------------------------------------------------------------------------------------------------------------------------------------------------------------------------------------------------------------------------------------------------------------------------------------------------------------------------------------------------------------------------------------------------------------------------------------------------------------------------------------------------------------------------------------------------------------------------------------------------------------------------------------------------------------------------------------------------------------------------------------------------------|
| <b>Name</b>           | vehicle_dashboard                                                                                                                                                                                                                                                                                                                                                                                                                                                                                                                                                                                                                                                                                                                                                                                                                                                                                                                                                                                                                                                                                                                                            |
| <b>Mockup</b>         |                                                                                                                                                                                                                                                                                                                                                                                                                                                                                                                                                                                                                                                                                                                                                                                                                                                                                                                                                                                                                                                                                                                                                              |
| <b>Aim</b>            | Display vehicle information and measured values                                                                                                                                                                                                                                                                                                                                                                                                                                                                                                                                                                                                                                                                                                                                                                                                                                                                                                                                                                                                                                                                                                              |
| <b>Purpose</b>        | Monitoring                                                                                                                                                                                                                                                                                                                                                                                                                                                                                                                                                                                                                                                                                                                                                                                                                                                                                                                                                                                                                                                                                                                                                   |
| <b>Status</b>         | Draft                                                                                                                                                                                                                                                                                                                                                                                                                                                                                                                                                                                                                                                                                                                                                                                                                                                                                                                                                                                                                                                                                                                                                        |
| <b>Missing</b>        | None                                                                                                                                                                                                                                                                                                                                                                                                                                                                                                                                                                                                                                                                                                                                                                                                                                                                                                                                                                                                                                                                                                                                                         |
| <b>Preferred size</b> | PC                                                                                                                                                                                                                                                                                                                                                                                                                                                                                                                                                                                                                                                                                                                                                                                                                                                                                                                                                                                                                                                                                                                                                           |
| <b>Style</b>          | PA                                                                                                                                                                                                                                                                                                                                                                                                                                                                                                                                                                                                                                                                                                                                                                                                                                                                                                                                                                                                                                                                                                                                                           |
| <b>Chat enabled</b>   | No                                                                                                                                                                                                                                                                                                                                                                                                                                                                                                                                                                                                                                                                                                                                                                                                                                                                                                                                                                                                                                                                                                                                                           |
| <b>Kind</b>           | Active                                                                                                                                                                                                                                                                                                                                                                                                                                                                                                                                                                                                                                                                                                                                                                                                                                                                                                                                                                                                                                                                                                                                                       |
| <b>Data vs Widget</b> | <p><b>Map Widget</b></p> <ul style="list-style-type: none"> <li>Description: map showing the vehicle position over time</li> <li>Kind: monitoring only</li> <li>Preferred Data representation: map</li> <li>Data: <code>Vehicle.latitude</code>, <code>Vehicle.longitude</code></li> </ul> <p><b>DataTable Widget</b></p> <ul style="list-style-type: none"> <li>Description: table reporting the vehicle events</li> <li>Kind: monitoring only</li> <li>Preferred Data representation: table</li> <li>Data: <code>VehicleEvent.eventID</code>, <code>VehicleEvent.dateObserved</code>, <code>VehicleEvent.status</code>, <code>VehicleEvent.kind</code></li> </ul> <p><b>SingleContent Widget</b></p> <ul style="list-style-type: none"> <li>Description: single content showing the total km travelled by the vehicle</li> <li>Kind: IoT App</li> <li>Preferred Data representation: single number</li> <li>Data: <code>Vehicle.kmTotal</code></li> </ul> <p><b>Synoptic Widget</b></p> <ul style="list-style-type: none"> <li>Description: battery shaped synoptic to represent the available energy percentage</li> <li>Kind: monitoring only</li> </ul> |

|                                   |                                                                                                                                                                                                                                                                                                           |
|-----------------------------------|-----------------------------------------------------------------------------------------------------------------------------------------------------------------------------------------------------------------------------------------------------------------------------------------------------------|
| <b>Client Side Business Logic</b> | <ul style="list-style-type: none"> <li>To be developed in JavaScript into the Dashboard Widget</li> <li>Event driven: .....</li> </ul>                                                                                                                                                                    |
| <b>Server Side Business Logic</b> | <ul style="list-style-type: none"> <li>To be developed in IoT App with S4C Dashboard Nodes</li> <li>IoT Application → <ul style="list-style-type: none"> <li>Event driven: .....</li> </ul> </li> <li>IoT Application → <ul style="list-style-type: none"> <li>Event driven: .....</li> </ul> </li> </ul> |

As can be seen in the example dashboard schema above, several information must be specified:

- Name:** name or ID of the dashboard
- Mockup:** a graphical example showing the overall appearance of the dashboard. This can be realized using some graphic painting tool (a screenshot of an empty dashboard can be used as background element)
- Aim:** a description of the dashboard
- Purpose:** it can be monitoring, simulation, what-if, data entry, etc. Multiple values are possible.
- Status:** it can be draft, developed, finalized, accepted
- Missing:** in this field list all missing element that should be included in future
- Preferred Size:** specify the preferred viewing size of the dashboard, such as PC, HD, mobile, or an explicit resolution size (row x column)
- Style:** the base style to be used for the dashboard. Available styles include Gea, `Ballon`, PA, `Ballon Dark`, etc.
- Chat enabled:** yes or no
- Kind:** passive or active. A passive dashboard show data taken from storage only, without sending actions toward an IoT App; however, passive dashboards may have selectors, maps, etc., and a lot of interactive visualization that do not requires neither changes in the status on server, nor sending commands to the server side. Differently, active dashboards, are those that send or receive commands to/from the server side, via some client-side Business Logic, server side Business Logic on IoT Apps, or both
- Data vs Widget:** for each widget required in the dashboard, some information must be specified according to the following schema:
  - Name: the name of the widget to be used
  - Description: a brief description of the widget and its use
  - Kind: monitoring, IoT App, or Client-Side business logic (note that, the last two entries characterize an active dashboard)
  - Data: the data the be used in the widget, typically retrieved from some IoT device. Multiple entries can be accepted.
- Client Side business logic:** to be specified if present
  - Description of the effects: a description of the implemented client-side business logic effects
- Server Side business logic:** to be specified if present
  - IoT App: description of the involved IoT App
  - Event driven: indicate to which events the IoT App responds

# Dashboard Kind

- **Passive Dashboards:** showing data taken from Storage only, no actions toward IoT App

- Passive dashboards may have Selectors, maps, etc., and a lot of visualization without changing the status on Server, no sending commands to the Server Side.

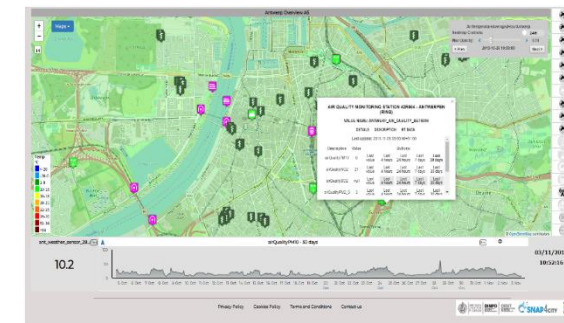

- **Custom Business Logic**

- **Active Dashboards,** which can be those sending or receiving commands to/from the logic coded somehow and in particular for

- **Server Side Business Logic** → logic on IoT Apps with Snap4City Dashboard Nodes, which is easier to be programmed begin based on Node-RED visual programming.
- **Client Side Business Logic** → logic on JavaScript on specific Dashboard Widgets only for skilled developers of Snap4City Platform. We suggest first prototype by using Server Side Business Logic, then pass to Client Side Business Logic in JavaScript.
- Both kind of Business Logics may be active on the same Active Dashboard.

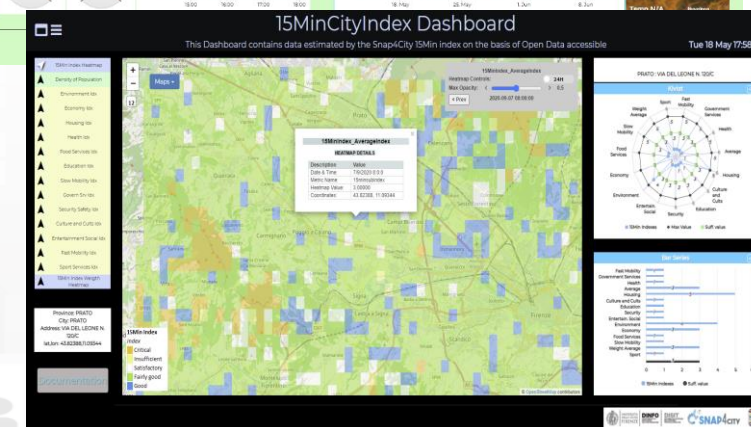
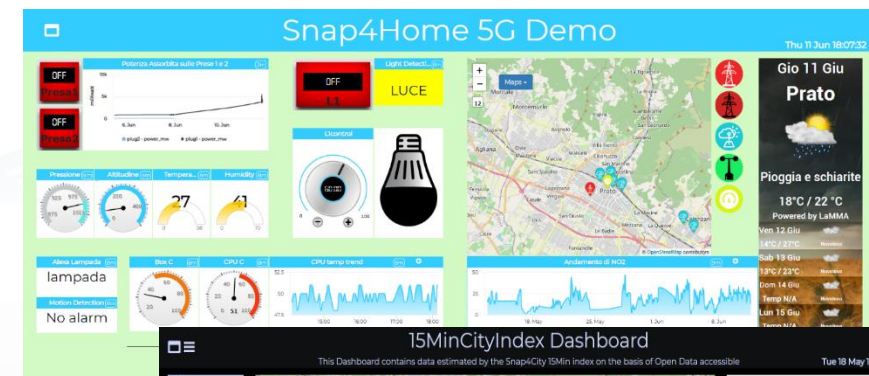

# How the Dashboards / Apps Exchange data (2024/8)

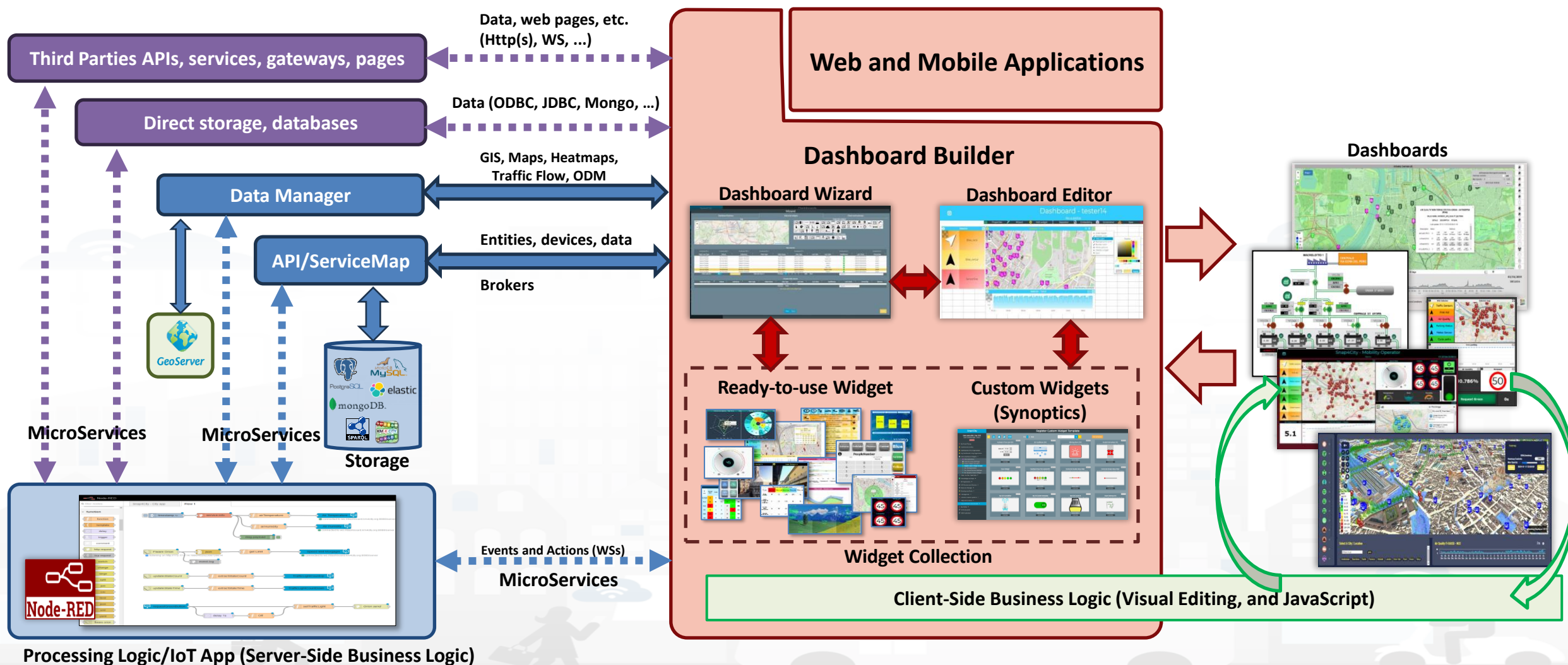



# Dashboard Widgets' Capabilities for Business Logics

| Widget name / description                                 | Event Driven | Some Local Interaction | Server-Side Business Logic Node-RED | Client-Side Business Logic (IN = JavaScript) |
|-----------------------------------------------------------|--------------|------------------------|-------------------------------------|----------------------------------------------|
| Single Content                                            | Yes          | --                     | OUT                                 | OUT                                          |
| Speedometer                                               | Yes          | --                     | OUT                                 | OUT                                          |
| Gauge                                                     | Yes          | --                     | OUT                                 | OUT                                          |
| MultiSeries, Time Series, Curved Line, time compare       | Yes          | Yes                    | OUT                                 | IN/OUT                                       |
| Time Trend, Time Series                                   | Yes          | Yes                    | OUT                                 | IN/OUT                                       |
| Spidernet, Radar                                          | Yes          | Yes                    | OUT                                 | IN/OUT                                       |
| BarSeries                                                 | Yes          | Yes                    | OUT                                 | IN/OUT                                       |
| Donut, Pie                                                | Yes          | Yes                    | OUT                                 | IN/OUT                                       |
| Device Table                                              | Yes          | Yes                    | IN/OUT                              | IN/OUT                                       |
| Multi Data Map (dashboard Map)                            | Yes          | Yes                    | IN/OUT                              | IN/OUT                                       |
| Selector                                                  | Yes          | Yes                    | --                                  | --                                           |
| Button, Impulse button                                    | Yes          | Yes                    | IN                                  | IN                                           |
| Switch, on/off but.                                       | Yes          | Yes                    | IN/OUT                              | IN/OUT                                       |
| Knob, Dimer                                               | Yes          | Yes                    | IN/OUT                              | IN/OUT                                       |
| Keypad, Num Pad                                           | Yes          | Yes                    | IN                                  | IN                                           |
| External Content                                          | Yes          | Yes                    | IN/OUT                              | IN/OUT                                       |
| Event Driven MyKPI                                        | Yes          | --                     | IN                                  | --                                           |
| Synoptics (see External Content) (read, write, subscribe) | Yes          | Yes                    | IN/OUT                              | --                                           |
| Dashboard Form                                            | Yes          | Yes                    | IN/OUT                              | Possible on Ext.Content                      |
| Speak Synthesis                                           | Yes          | --                     | OUT                                 | Possible on Ext.Content                      |
| D3 charts                                                 | Yes          | Yes                    | OUT                                 | --                                           |

See for this column CSBL PDF

TOP

# *Develop: via Dashboard Wizard*



# Dashboard Builder: Development

Data Transformation  
Business Logic

IOT Applications

Knowledge Base,  
Km4City

Knowledge and Storage  
Data from the Field and  
City + MyKPI ++



Widget Collection

Micro Applications

External Services

Custom Widgets/  
Synoptics

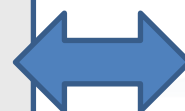
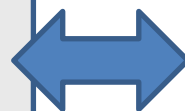

Dashboard Wizard

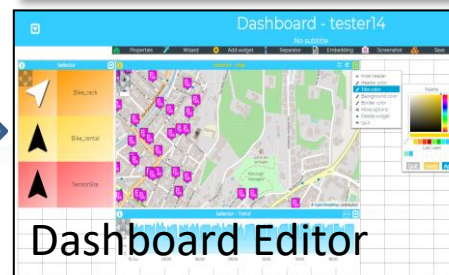
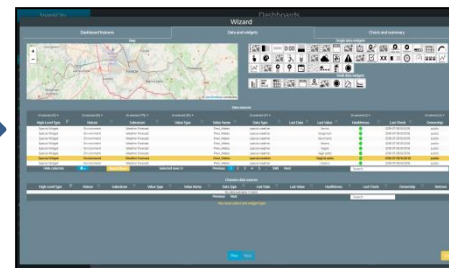

Create, save, load,  
delegate, grant access,  
change ownership



Public  
Dashboard  
Collection

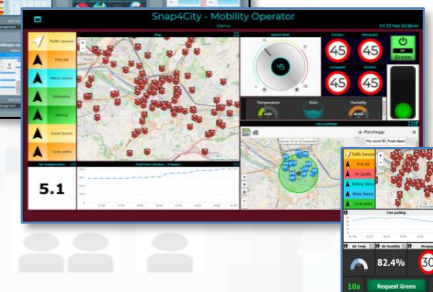

My Own Dash/App



# New Dash ?

The screenshot displays the SNAP4CITY dashboard interface. At the top, it shows the user profile: "User: paolo.disit, Org: DISIT, Role: AreaManager, Level: 3" with a "LOGOUT" link and a "Switch to Legacy Layout" button. The main heading is "My Dashboards in My Organization". A sidebar on the left contains navigation options like "Dashboards (Public)", "My Snap4City.org", "Tour Again", and a list of dashboard categories including "www.snap4solutions.org", "Dashboards of My Organization", "My Dashboards in My Organization", "My Data Dashboard Dev Kibana", "Extra Dashboard Widgets", "Data Management, HLT", "Knowledge and Maps", "Processing Logics / IOT App", "Entity Directory and Devices", "Resource Manager", "Development Tools", "Management", and "Decision Support Systems". The main area features a grid of dashboard cards, each with a preview image, a title, a description, and ownership information. A red hand icon points to a green "NEW DASHBOARD" button in the top right corner of the dashboard grid.

| Dashboard Title                                    | Description          | Ownership              |
|----------------------------------------------------|----------------------|------------------------|
| Alerting Generation                                | Proc.Logic / IoT App | My own: Public (DISIT) |
| Andamenti Nazionali e Regionali infezione COVID-19 | Proc.Logic / IoT App | My own (DISIT)         |
| Andamento Regione Toscana e Province, COVID-19     | Proc.Logic / IoT App | My own (DISIT)         |
| Case 1 SVG ws3                                     | Proc.Logic / IoT App | My own (DISIT)         |
| case 2 SVG WS3                                     | Proc.Logic / IoT App | My own (DISIT)         |
| Case4 svg                                          | Passive              | My own (DISIT)         |
| Change Alert Color Status                          | Proc.Logic / IoT App | My own: Public (DISIT) |
| DataCenter new Device DHT                          | Proc.Logic / IoT App | My own: Public (DISIT) |
| Device Table Testing double                        | Proc.Logic / IoT App | My own (DISIT)         |
| DIDA data 2                                        | Passive              | My own: Public (DISIT) |

## Wizard



## Dashboard features

## Data and widgets

## Map

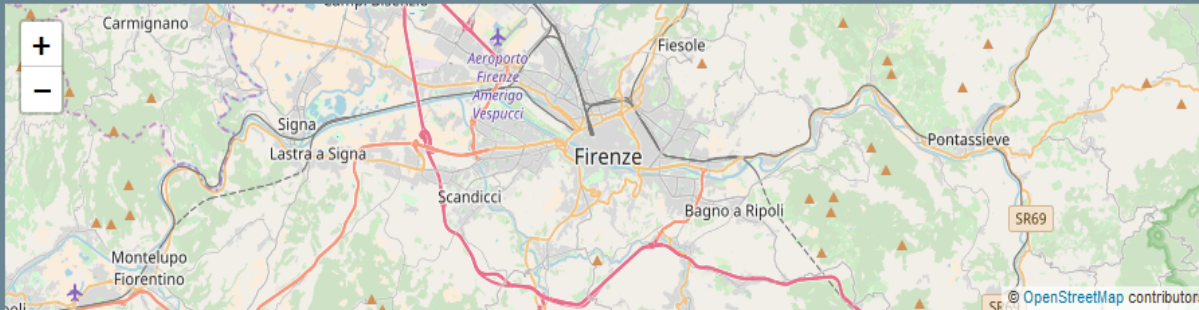

## Single data widgets



## Multi data widgets



## Data sources

| High-Level Type | Nature      | Subnature        | Value Type  | Value Name  | Data Type       | Last Date | Healthiness | Last Check          | Ownership |
|-----------------|-------------|------------------|-------------|-------------|-----------------|-----------|-------------|---------------------|-----------|
| Special Widget  | Environment | Weather Forecast | Previ_Meteo | Previ_Meteo | special weather |           |             | 2018-07-08 16:00:18 | public    |
| Special Widget  | Environment | Weather Forecast | Previ_Meteo | Previ_Meteo | special weather |           |             | 2018-07-08 16:00:18 | public    |
| Special Widget  | Environment | Weather Forecast | Previ_Meteo | Previ_Meteo | special weather |           |             | 2018-07-08 16:00:18 | public    |
| Special Widget  | Environment | Weather Forecast | Previ_Meteo | Previ_Meteo | special weather |           |             | 2018-07-08 16:00:18 | public    |
| Special Widget  | Environment | Weather Forecast | Previ_Meteo | Previ_Meteo | special weather |           |             | 2018-07-08 16:00:18 | public    |
| Special Widget  | Environment | Weather Forecast | Previ_Meteo | Previ_Meteo | special weather |           |             | 2018-07-08 16:00:18 | public    |
| Special Widget  | Environment | Weather Forecast | Previ_Meteo | Previ_Meteo | special weather |           |             | 2018-07-08 16:00:18 | public    |
| Special Widget  | Environment | Weather Forecast | Previ_Meteo | Previ_Meteo | special weather |           |             | 2018-07-08 16:00:18 | public    |
| Special Widget  | Environment | Weather Forecast | Previ_Meteo | Previ_Meteo | special weather |           |             | 2018-07-08 16:00:18 | public    |

• Select the area of your interest: panning and zooming

• Select the

• graphic aspect of your interest, or

• High Level Type of your interest, or

• Make a search if you have a precise idea or

• Act on filters: nature, subnature, type, name, value, date, health, owner, ...

• Combine them as you like

• Select the lines of your interest

• Then click on Next and get the Dashboard by wizard



Close

# New Data Inspector/Wizard

New Wizard

Data Inspector BETA OS

The interface includes a map of Florence, a dashboard with various widgets, a table of data sources, and a time-series graph. The table below shows the data sources:

| Level | Type       | Nature             | Subnature  | Device            | Model | Broker             | Value Name          | Value Type | Data Type | Value Unit | Last Date           | Last Value | Healthiness | Last Check         | Ownership |
|-------|------------|--------------------|------------|-------------------|-------|--------------------|---------------------|------------|-----------|------------|---------------------|------------|-------------|--------------------|-----------|
| DT    | EM Devi... | Environment        | Weather    | DIDA1             |       | Santa Verdiana ... | Mio sensore         |            | webpage   |            | 2021-11-23 13:44... |            | ●           | 2023-07-18 16:0... | public    |
| DT    | EM Devi... | TransferService... | SensorSite | METRO11           |       | Altair-soda        | Altair Valve State  |            | webpage   |            | 2021-06-05 00:00... |            | ●           | 2024-01-10 01:3... | public    |
| DT    | EM Devi... | IndustryAndMa...   | Computer   | AltairStatoPom... |       | Altair-soda        | Altair Pump St...   |            | webpage   |            | 2021-05-20 13:51... |            | ●           | 2024-01-10 01:3... | public    |
| DT    | EM Devi... | Environment        | Air        | IBIMET_SMART...   |       | Altair-soda        | Altair Pump 43...   |            | webpage   |            | 2021-06-07 17:3...  |            | ●           | 2024-01-10 01:3... | public    |
| DT    | EM Devi... | Environment        | Air        | ARPAT_QA_FI...    |       | Altair-soda        | Altair valve 541    |            | webpage   |            | 2021-06-07 17:3...  |            | ●           | 2024-01-10 01:3... | public    |
| DT    | EM Devi... | TransferService... | SensorSite | METRO514          |       | Altair-soda        | Altair Pump 4321    |            | webpage   |            | 2021-06-07 00:00... |            | ●           | 2024-01-10 01:3... | public    |
| DT    | EM Devi... | TransferService... | SensorSite | SI052032F5990...  |       | Altair-soda        | Altair Stock sta... |            | webpage   |            | 2021-06-07 00:00... |            | ●           | 2024-01-10 01:3... | public    |
| DT    | EM Devi... | TransferService... | SensorSite | METRO831          |       | Altair-soda        | Altair Pump 92...   |            | webpage   |            | 2021-06-07 00:00... |            | ●           | 2024-01-10 01:3... | public    |

- Filtering/Searching for individual fields (even for some fields not displayed as geographic coordinates)
- Geographic Filtering
- Text Search on all fields
- Menu for choosing the fields to display in the table
- View on Map(via PREVIEW)
- Data and Trend visualization
- Opening Digital Twin
- Pass to Synoptic mode
- Select the graph representation

SNAP4CITY Dashboards Wizard

Dashboard features | Data and widgets | Check and summary

Map

Single data widgets

Multi data widgets

| High-Level Type | Nature      | Subnature        | Value Type  | Value Name      | Last Date           | Last Value | Healthiness | Last Check          | Ownership |
|-----------------|-------------|------------------|-------------|-----------------|---------------------|------------|-------------|---------------------|-----------|
| Special Widget  | Environment | Weather Forecast | Prevl_Meteo | special weather | 2018-07-08 16:00:18 | Vernio     | ●           | 2018-07-08 16:00:18 | public    |
| Special Widget  | Environment | Weather Forecast | Prevl_Meteo | special weather | 2018-07-08 16:00:18 | Vergemoli  | ●           | 2018-07-08 16:00:18 | public    |
| Special Widget  | Environment | Weather Forecast | Prevl_Meteo | special weather | 2018-07-08 16:00:18 | Vecchiano  | ●           | 2018-07-08 16:00:18 | public    |
| Special Widget  | Environment | Weather Forecast | Prevl_Meteo | special weather | 2018-07-08 16:00:18 | Valiano    | ●           | 2018-07-08 16:00:18 | public    |
| Special Widget  | Environment | Weather Forecast | Prevl_Meteo | special weather | 2018-07-08 16:00:18 | Vaglia     | ●           | 2018-07-08 16:00:18 | public    |
| Special Widget  | Environment | Weather Forecast | Prevl_Meteo | special weather | 2018-07-08 16:00:18 | Vaglia     | ●           | 2018-07-08 16:00:18 | public    |

Chosen data sources

You must select one widget type

Prev Next

# Dashboard Wizard

**Wizard**

## Test api from Time

Thu 8 Mar 09:18:52

**Selector**

- Traffic Sensors
- First Aid
- Smart waste
- Meteo sensor in via Bolognese
- Air quality
- Pollination
- Parking Status
- Smart bench
- Bike sharing (Pisa)

**METRO759**

DETAILS DESCRIPTION RT DATA

Last update: 2018-03-08 09:10:00-01:00

| Description   | Value    | Buttons    |              |               |             |              |
|---------------|----------|------------|--------------|---------------|-------------|--------------|
| Avg Time      | 1.635227 | Last value | Last 4 hours | Last 24 hours | Last 7 days | Last 30 days |
| Concentration | 7.064071 | Last value | Last 4 hours | Last 24 hours | Last 7 days | Last 30 days |
| Vehicle Flow  | 844.0    | Last value | Last 4 hours | Last 24 hours | Last 7 days | Last 30 days |
| Average       | 29.86946 | Last value | Last 4 hours | Last 24 hours | Last 7 days | Last 30 days |

Vehicle Flow - 30 days

The Wizard help you in selecting only possible combination of data vs graphic representation

TOP

# *Develop:* *Dashboard Synoptics*





## Custom Widget / Synoptic / PIN Development

Inkscape editor on your computer



Create, save a Custom Widget in SVG



Create, save, load, delegate, grant access

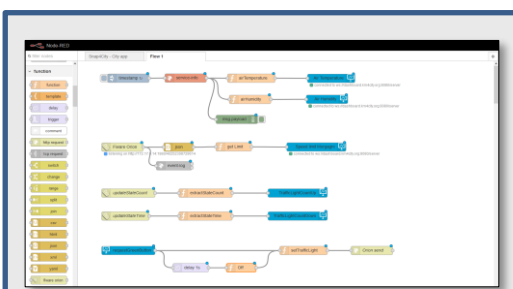

IOT Applications



Knowledge and Storage Data from the Field and City

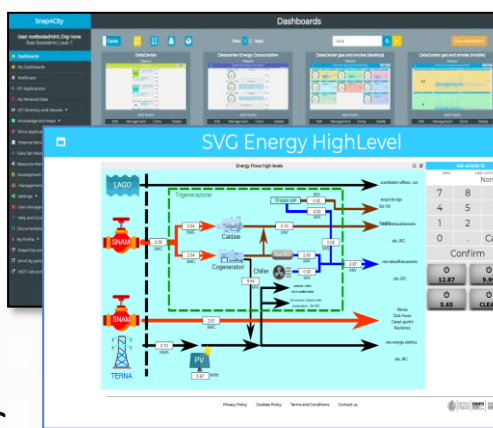
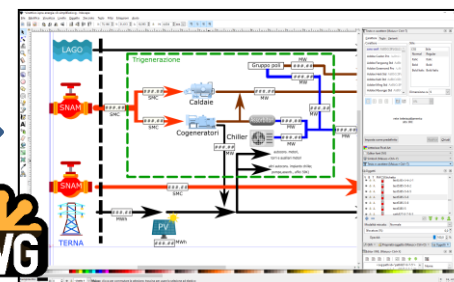
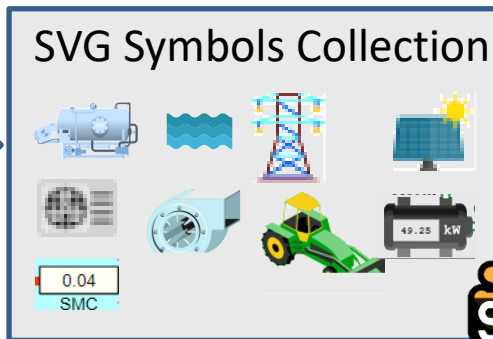

Public

Dashboard Collection

My Own Dash/App



1. Create and Load a Custom SVG
2. Select/Reuse an SVG
3. Make and Instance of Synoptic by Associate Variables with MyKPI
4. Create on Dashboard a Widget based on Synoptic HLT such as Ext. Srv.:

- <https://www.snap4city.org/synoptic/v2/synoptic.html?id=xxxx>

**Create, save a Custom  
Widget in SVG**

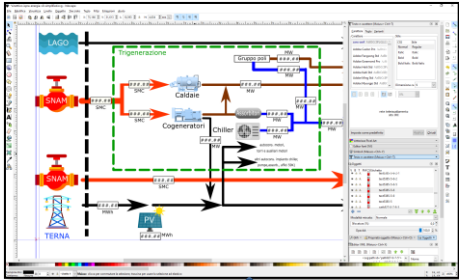

**Upload as  
Custom Widget Template**

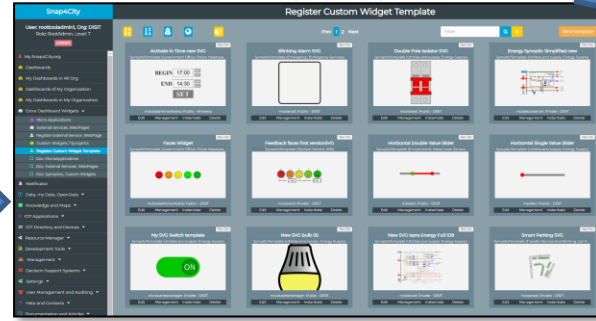

**List of Custom  
Widgets / Synoptics**

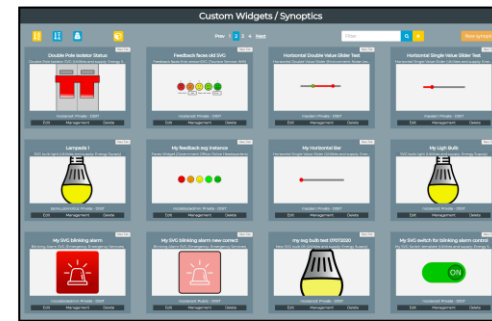

**Dashboard Editing/wizard**

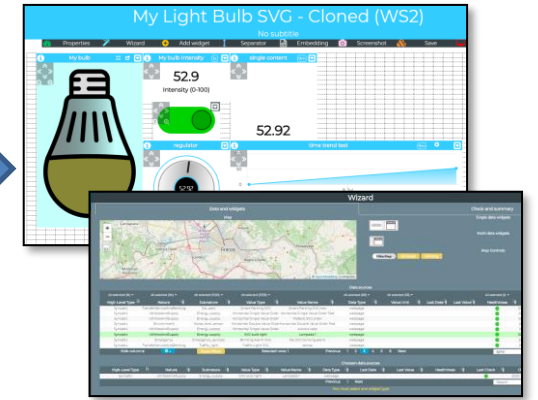

**SVG Symbols Collection**



From any open library

select

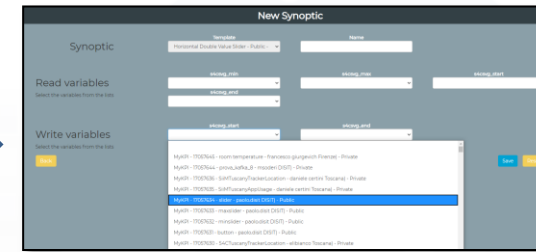
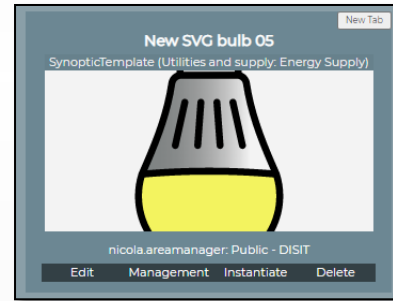

**Instantiate as  
Custom Widgets /  
Synoptics  
Connect with  
WebSockets**

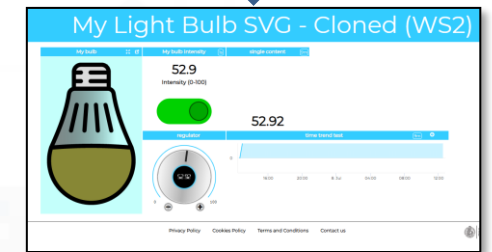

**Final Dashboard**

**Select MyKPI and  
Sensor Data for  
Synoptics cases**

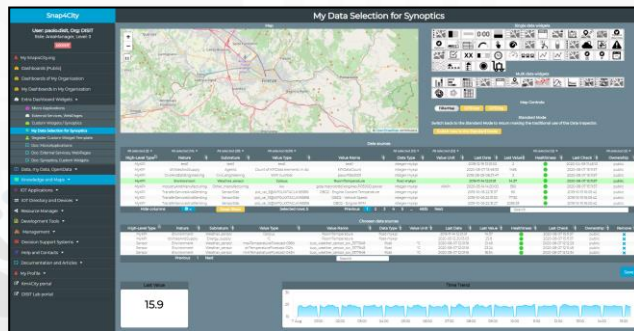

**Part 3**

## Special Custom Widgets

- Smart parking
- Smart Energy
- Smart Light
- Smart ....
- Energy View
- Custom Controls

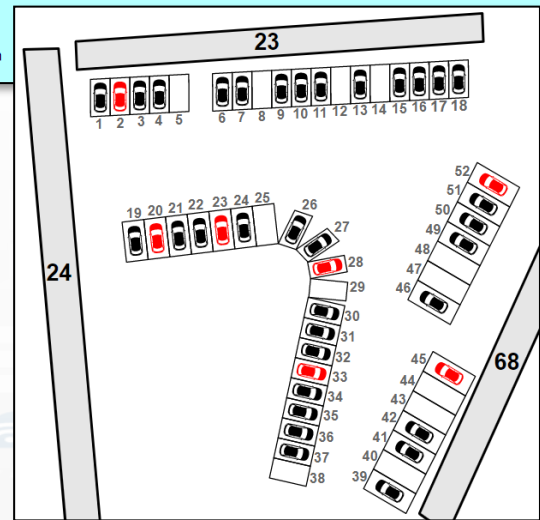
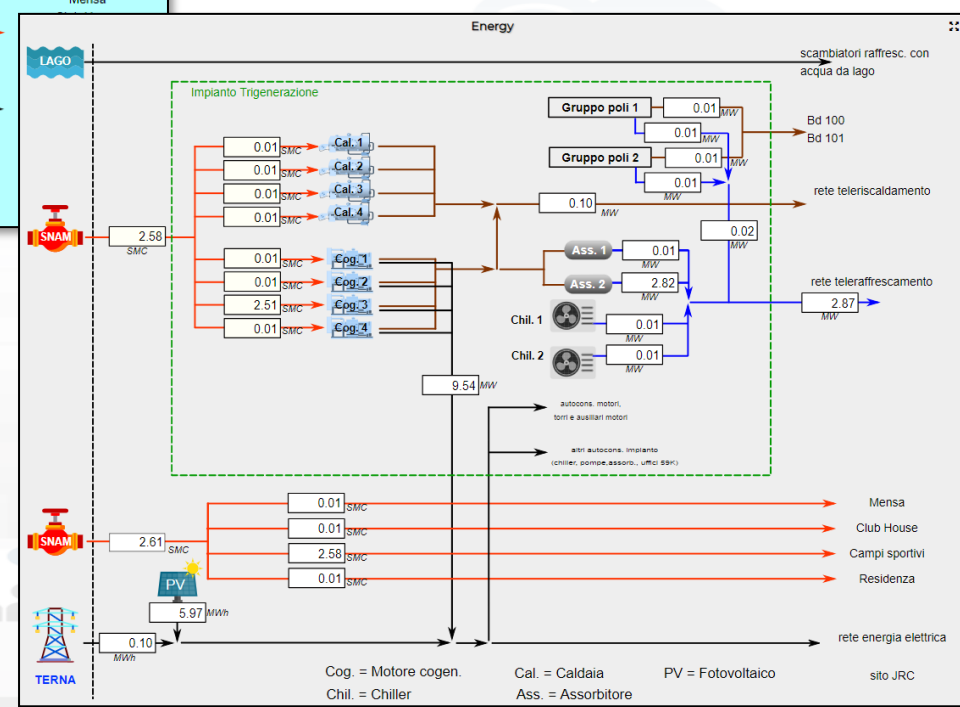
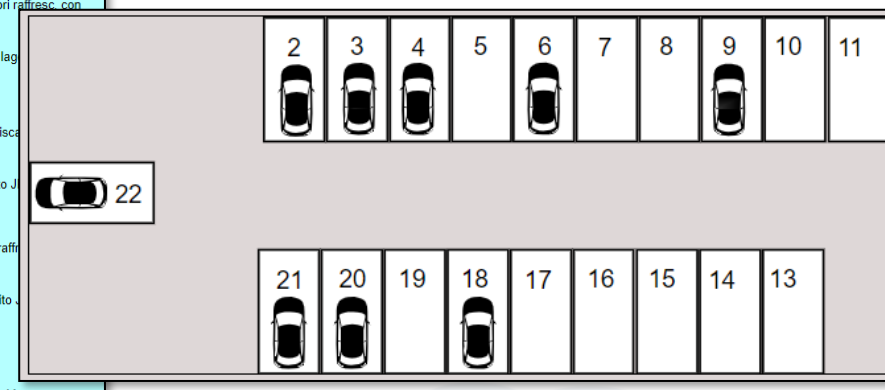
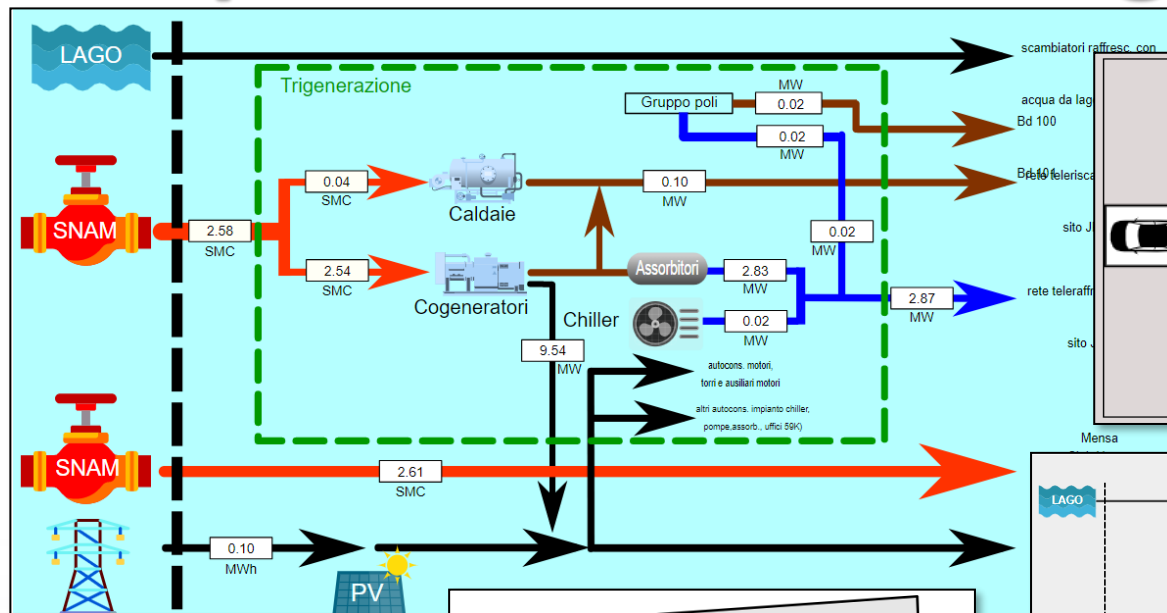

Custom control widget with a row of 5 smiley faces (from -2 to 2). Below the faces, it displays "Total clicks" with a value of 6 and "Mean rate value" with a value of 0.00.

Custom control widget for time settings. It shows "Begin" at 17:00 and "Finish" at 4:00. Below the time fields are two rows of smiley faces for adjustment.

## From-To Custom Widgets / Synoptics to Storage in WS

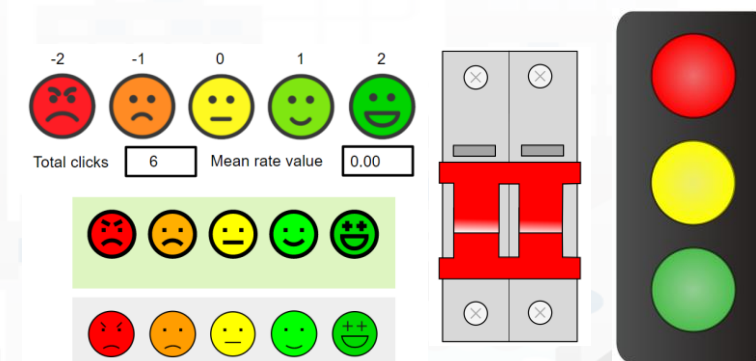
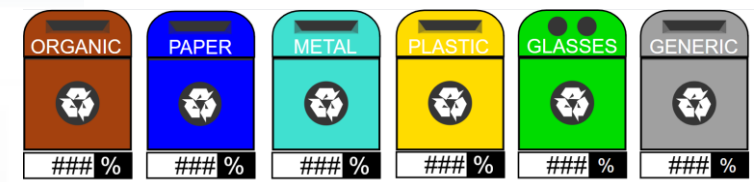
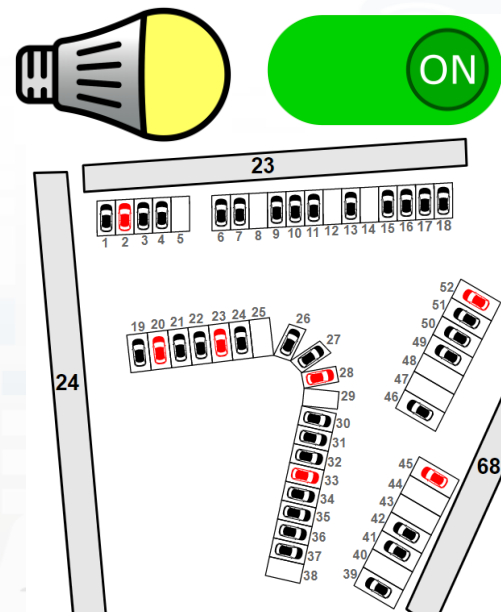
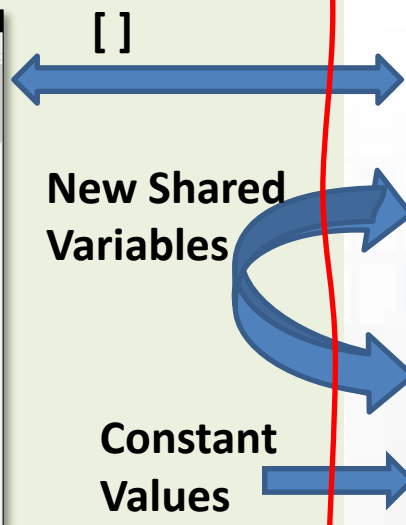
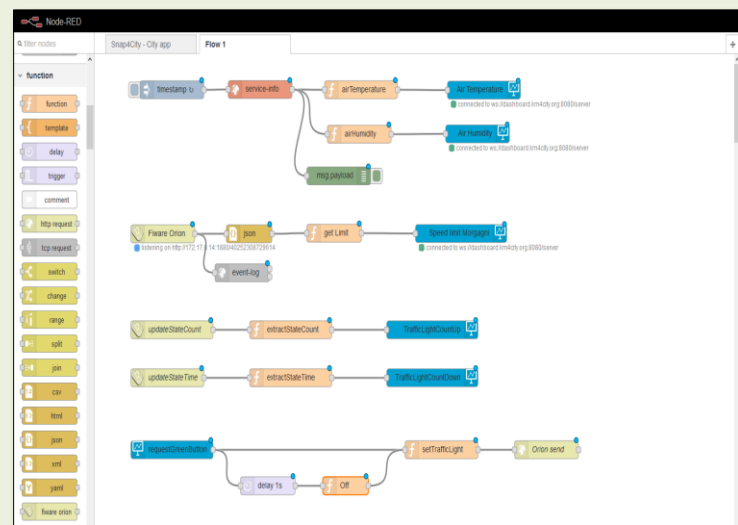
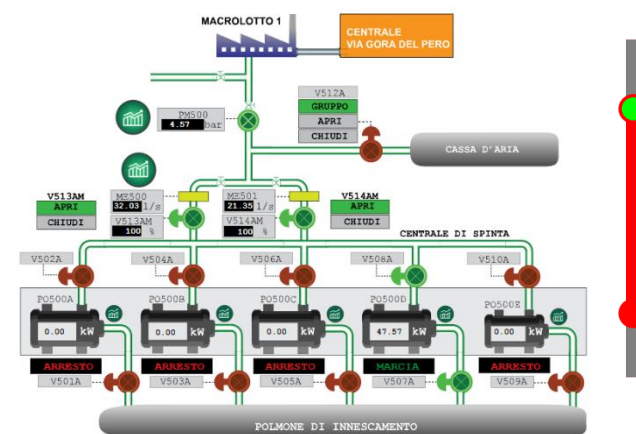
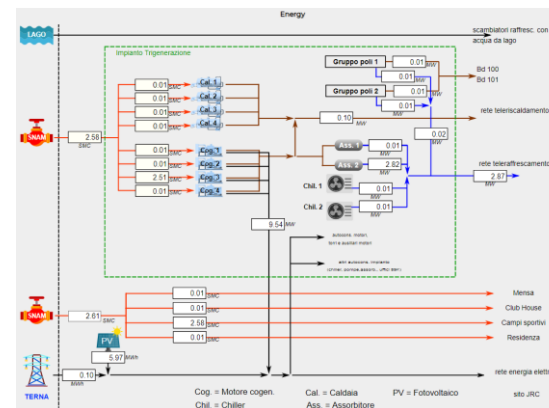
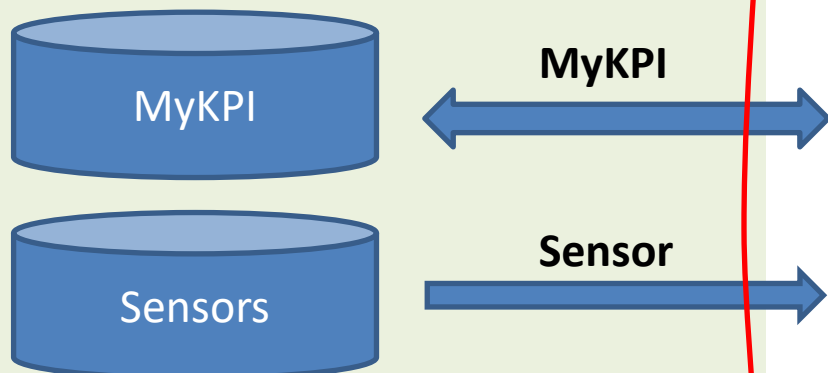

## SVG Custom Widgets Examples

Sat 16 Jan 01:07:39

Precedence Italians Road signals

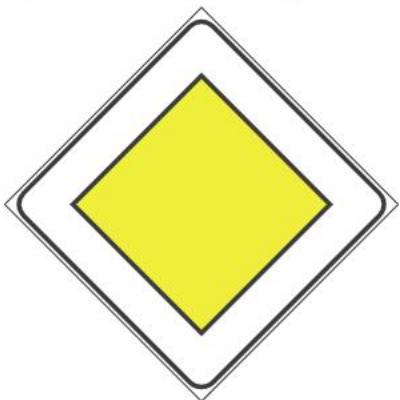

Select a code from 0 to 11 to change the road sign

| New     |   | Last confirmed |  |
|---------|---|----------------|--|
| None    |   |                |  |
| 7       | 8 | 9              |  |
| 4       | 5 | 6              |  |
| 1       | 2 | 3              |  |
| 0       | . | Canc           |  |
| Confirm |   |                |  |

Smart Light Luminosity



Air Temperature in Florence

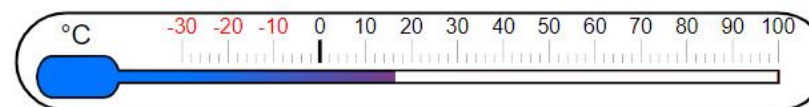

fan

Fan velocity



PM10 level - Bologna

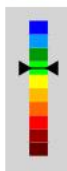

open/...



Dynamic Prohibition...



Prohibition Traffic Signs Co...

| New     |   | Last confirmed |  |
|---------|---|----------------|--|
| None    |   |                |  |
| 7       | 8 | 9              |  |
| 4       | 5 | 6              |  |
| 1       | 2 | 3              |  |
| 0       | . | Canc           |  |
| Confirm |   |                |  |



Prohibition Traffic Signs Legend



Symbols Legend

- ▲ NaOH KOH -1
- ▲ NaOH KOH -2
- ▲ HCl
- ▲ Cloroparaffine
- ▲ Cloruro di Ferro
- ▲ Cloruro Ferrico Ferroso Pot
- ▲ Cloruro Ferrico Ferroso Pot

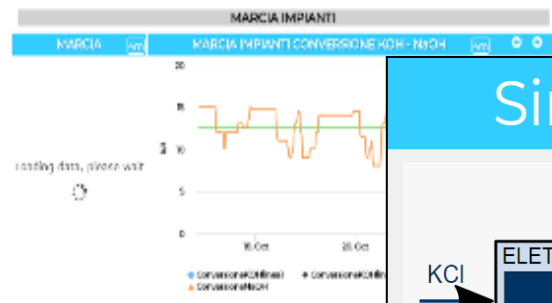
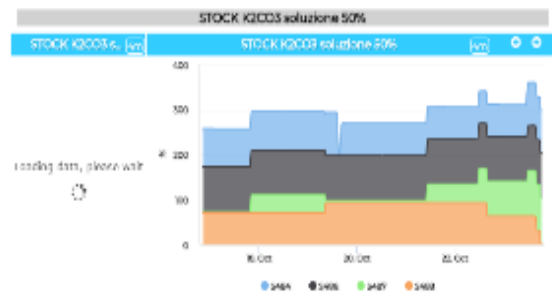
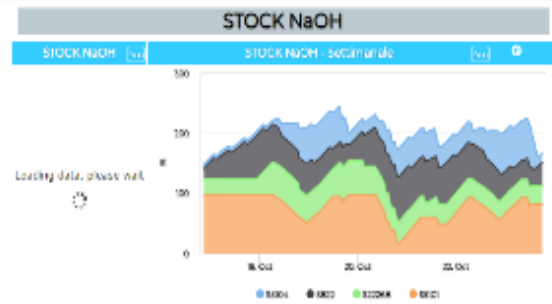
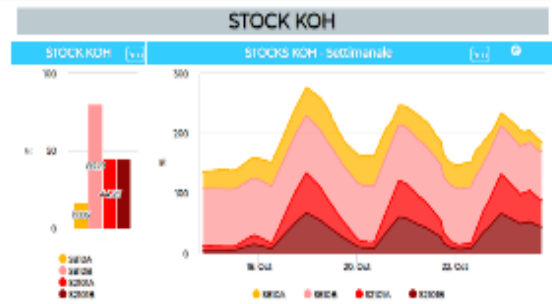

- Home
- DCS Real Time VS Planning
- DCS Real Time Giornaliero
- DCS Real Time Settimanale
- DCS Marce Giornaliero
- DCS Marce Settimanale
- DCS Stoccaggi



## Sinottico Sintesi Impianto Altair 2

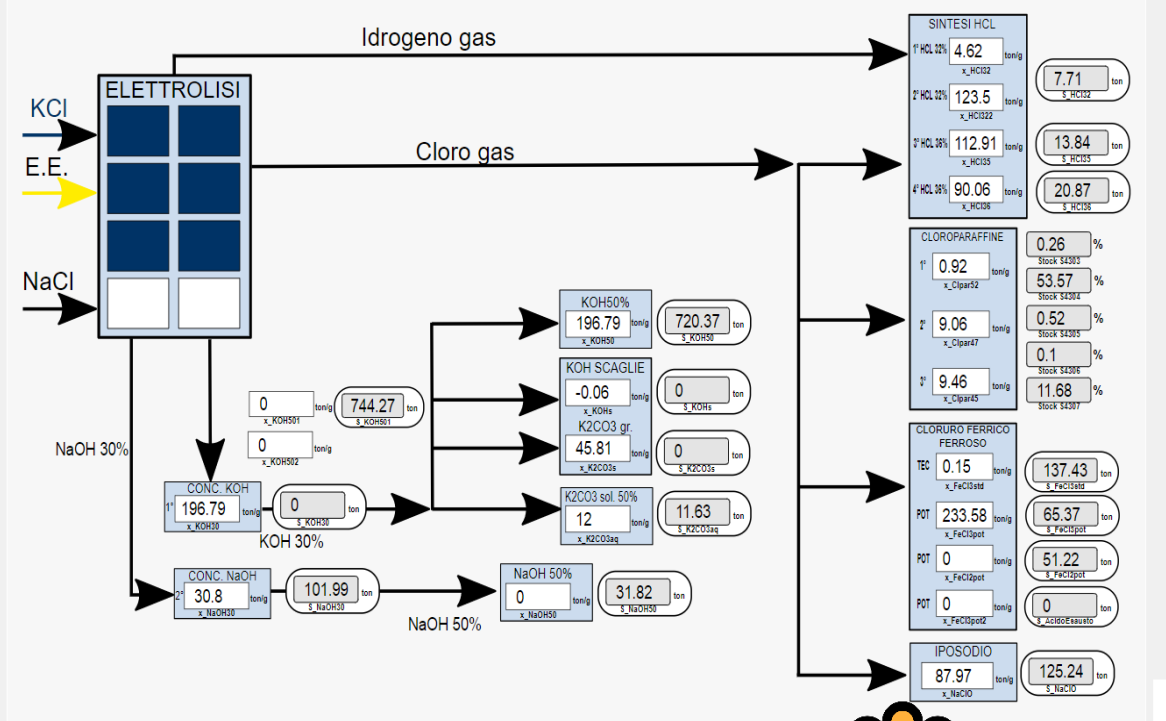

- DCS Real Time VS Planning
- DCS Real Time Giornaliero
- DCS Real Time Settimanale
- DCS Marce Giornaliero
- DCS Marce Settimanale
- DCS Stoccaggi Giornaliero
- DCS Stoccaggi Settimanale

Sinottico di sintesi impianto (ton/g)

Sinottico di sintesi impianto (ton/h)

## RTO online

| Localizzazione (id data) | Energia (PUN)       | Altri Parametri     | Pianificazione      | Esito Pianificazione | In Produzione                       |
|--------------------------|---------------------|---------------------|---------------------|----------------------|-------------------------------------|
| 0-01 09:32:54            | 2020-10-01 23:00:00 | 2020-07-24 18:43:00 | 2020-10-01 09:33:27 | completato           | <input type="checkbox"/>            |
| 0-30 17:20:50            | 2020-09-30 23:00:00 | 2020-07-24 18:43:00 | 2020-09-30 17:21:00 | completato           | <input checked="" type="checkbox"/> |
| 0-30 16:24:57            | 2020-09-30 23:00:00 | 2020-07-24 18:43:00 | 2020-09-30 16:27:23 | completato           | <input type="checkbox"/>            |
| 0-30 14:54:11            | 2020-09-30 23:00:00 | 2020-07-24 18:43:00 | 2020-09-30 14:56:22 | completato           | <input type="checkbox"/>            |
| 0-30 13:43:47            | 2020-09-30 23:00:00 | 2020-07-24 18:43:00 | 2020-09-30 13:43:57 | completato           | <input type="checkbox"/>            |
| 0-29 19:03:27            | 2020-09-30 23:00:00 | 2020-07-24 18:43:00 | 2020-09-29 19:03:43 | completato           | <input type="checkbox"/>            |
| 0-28 18:30:13            | 2020-09-29 23:00:00 | 2020-07-24 18:43:00 | 2020-09-28 18:30:23 | completato           | <input type="checkbox"/>            |
| 0-28 17:57:14            | 2020-09-29 23:00:00 | 2020-07-24 18:43:00 | 2020-09-28 17:57:23 | completato           | <input type="checkbox"/>            |
| 0-28 15:50:21            | 2020-09-28 23:00:00 | 2020-07-24 18:43:00 | 2020-09-28 15:50:45 | completato           | <input type="checkbox"/>            |
| 0-25 18:46:02            | 2020-09-26 23:00:00 | 2020-07-24 18:43:00 | 2020-09-25 18:47:46 | completato           | <input checked="" type="checkbox"/> |

- DCS Real Time VS Planning
- DCS Real Time Giornaliero
- DCS Real Time Settimanale
- DCS Marce Giornaliero
- DCS Marce Settimanale
- DCS Stoccaggi Giornaliero
- DCS Stoccaggi Settimanale

Sinottico di sintesi impianto





# IoT App / Proc.Logic

- Storage → IoT App / Proc.Logic
- External Service ↔ IoT App / Proc.Logic **Part 3**
- **Dashboards ↔ IoT App / Proc.Logic**

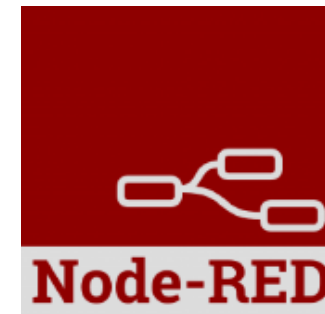

- Data Analytics ↔ IoT App / Proc.Logic **Part 4**
  - Broker → Storage
  - IoT App / Proc.Logic → Broker
  - Broker → IoT App / Proc.Logic
  - IoT App / Proc.Logic → Storage
- Part 5**



# Principles of Server Side Business Logic

- It is possible to have one Processing Logic (IoT App) referring to multiple Dashboards, and one Dashboard referring multiple Processing Logic (IoT Apps)
- Let see a 1:1 relationship from Proc.Logic and Dashboard
  - Any Action performed on Dashboard is provided to the Proc.Logic, which may produce reactions on Dashboard.
  - The context of Proc.Logic  $\leftrightarrow$  Dashboard is a singleton, thus any user connected to the Dashboard will observe the evolutions performed. So that all the users will see the same story and view
  - This is good for control rooms, and single/few users prototypes

# How the Dashboards exchange data

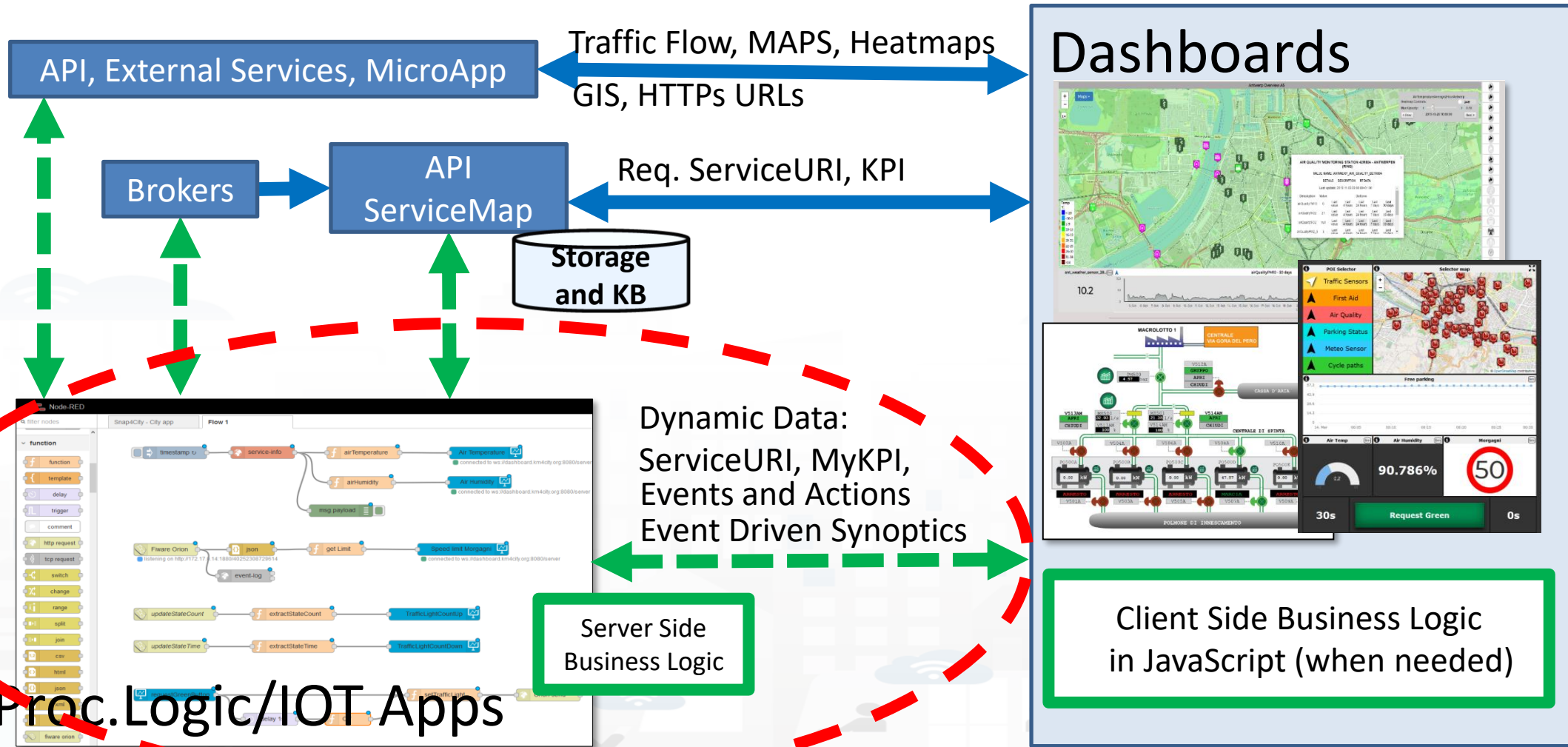

# Maps Server Side Business Logic vs IOT Apps

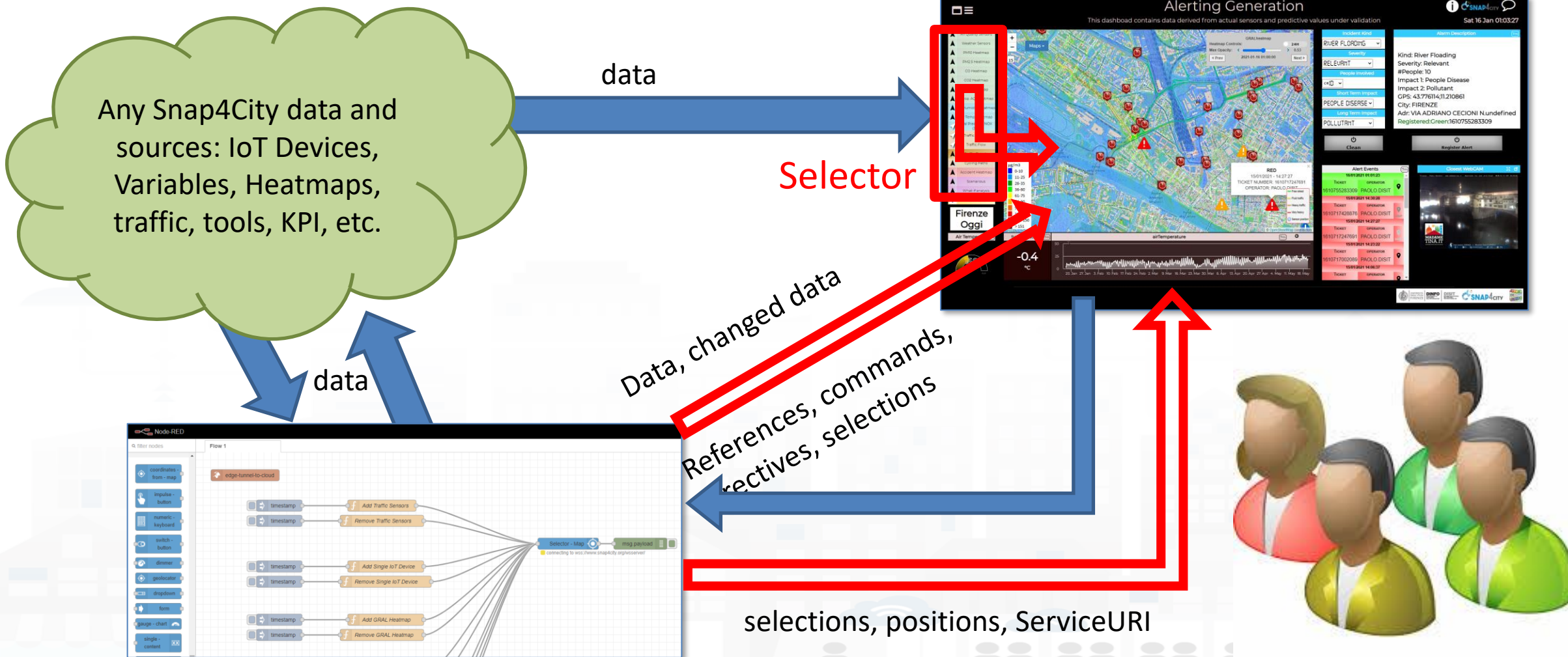



| Widgets ICONS | Widget Name, Description                          | IOT App | Dashboard-IOT App | KPI (metric)          | MyPersonalID ata | MyData | My KPI | Sensor |
|---------------|---------------------------------------------------|---------|-------------------|-----------------------|------------------|--------|--------|--------|
|               | Single Content                                    | X (cs)  | X (ED)            | X                     | X                | X      | X      | X      |
|               | Custom widgets in SVG are data driven             | X (cs)  | X (ED)            |                       |                  |        | X      | X      |
|               | Speedometer, Gauge                                | X (cs)  | X (ED)            | X                     | X                | X      | X      | X      |
|               | Device Table                                      | X (cs)  | X (ED)            |                       |                  |        | X      | X      |
|               | Single Bar, V/H                                   | X       | X (ED)            | X                     |                  |        |        |        |
|               | Single and Multiple Bars, stacked or not, ordered | X (cs)  | X (ED)            | X                     | X                | X      | X      | X      |
|               | MultiSeries, shaded, staked and non staked, TTT   | X (cs)  | X (ED)            | X                     | X                | X      | X      | X      |
|               | Time Trend (single)                               | X       | X (ED)            | X                     | X                | X      | X      | X      |
|               | Time Trend Compare                                |         |                   | X                     |                  |        | X      | X      |
|               | SpiderNet, radar, Kiviati                         | X (cs)  | X (ED)            | X                     | X                | X      | X      | X      |
|               | Pie, Donut, 2 layers Donut                        | X (cs)  | X (ED)            | X                     | X                | X      | X      | X      |
|               | Table                                             | X (cs)  | X (ED)            | X                     | X                | X      | X      | X      |
|               | Calendar                                          | X (cs)  | X (ED)            |                       |                  |        | X      | X      |
|               | Speak Synthesis                                   | X (cs)  | X (ED)            |                       |                  |        | string | string |
|               | Maps                                              | X (cs)  | X (ED)            | Many High Level Types |                  |        | X      | X      |

DD: Event Driven

# Widgets and their counterpart Nodes

- **Send** information and commands to the Dashboard Widget, for example for an action produced by the users. (**in widget/node**)
- **Receive** information and commands from the Dashboard Widget, for example presenting a dashboard change to the users. (**out widget/node**).
- **Send/receive** information and commands to/from the Dashboard Widget, for example for collecting users' actions and presenting a change to the users on the same widget (**in/out widget/node**).

On Server-Side (into Proc.Logic) the developer can even create some HTML pages and provide them into a Dashboard Widget. And a mixt of Widgets in, out, in/out

# Advanced IOT Applications

- **Synoptics can .....**
  - do all 😊
- **Widgets can**
  - send/receive dynamic data,
  - change data sources, etc.
  - Provide interactive maps
- **HTML pages can**
  - be dynamically generated
  - provide forms to produce data for IOT Applications
  - Collect files on web and system
  - produce files on web ad system
  - have CSS and AJAX control

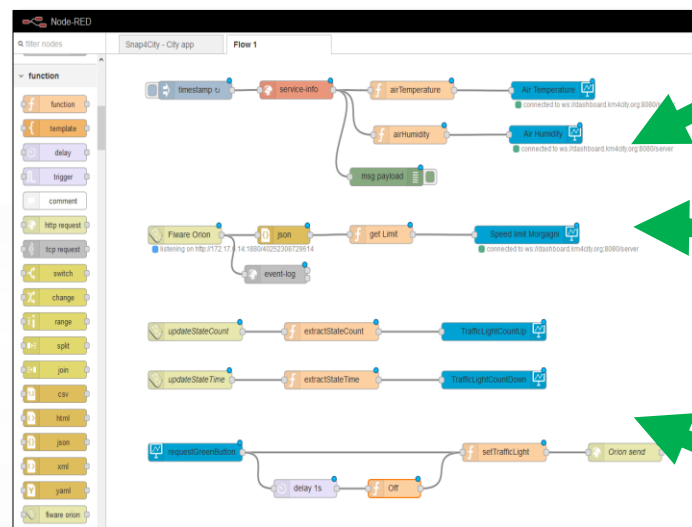

Synoptics  
Custom  
Widgets

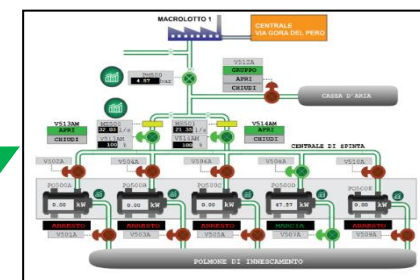

Widgets  
Maps  
Buttons  
Keypads  
Controls



HTML pages  
HTML Forms  
HTML Tables

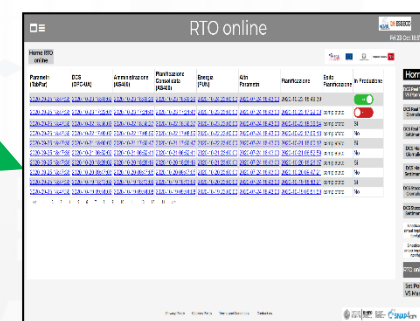

<https://www.snap4city.org/394>

<https://www.snap4city.org/596>

# Proc.Logic (IoT App) with Dynamic Web Pages

RTO online  
Fri 23 Oct 18:57:41

| Parametri (TabPar)                  | DCS (OPC-UA)                        | Amministrazione (AS400)             | Pianificazione Consolidata (AS400)  | Energia (PUN)                       | Altri Parametri                     | Pianificazione      | Esito Pianificazione | In Produzione            |
|-------------------------------------|-------------------------------------|-------------------------------------|-------------------------------------|-------------------------------------|-------------------------------------|---------------------|----------------------|--------------------------|
| <a href="#">2020-09-25 18:47:36</a> | <a href="#">2020-10-23 18:49:02</a> | <a href="#">2020-10-23 18:49:29</a> | <a href="#">2020-10-23 18:49:29</a> | <a href="#">2020-10-24 23:00:00</a> | <a href="#">2020-07-24 18:43:00</a> | 2020-10-23 18:49:39 |                      | <input type="checkbox"/> |
| <a href="#">2020-09-25 18:47:36</a> | <a href="#">2020-10-23 17:22:03</a> | <a href="#">2020-10-23 17:21:46</a> | <a href="#">2020-10-23 17:21:46</a> | <a href="#">2020-10-23 23:00:00</a> | <a href="#">2020-07-24 18:43:00</a> | 2020-10-23 17:22:08 | completato           | <input type="checkbox"/> |
| <a href="#">2020-09-25 18:47:36</a> | <a href="#">2020-10-22 18:36:02</a> | <a href="#">2020-10-22 18:36:27</a> | <a href="#">2020-10-22 18:36:27</a> | <a href="#">2020-10-23 23:00:00</a> | <a href="#">2020-07-24 18:43:00</a> | 2020-10-22 18:36:54 | completato           | <input type="checkbox"/> |
| <a href="#">2020-09-25 18:47:36</a> | <a href="#">2020-10-22 17:09:02</a> | <a href="#">2020-10-22 17:08:59</a> | <a href="#">2020-10-22 17:08:59</a> | <a href="#">2020-10-22 23:00:00</a> | <a href="#">2020-07-24 18:43:00</a> | 2020-10-22 17:09:13 | completato           | <input type="checkbox"/> |
| <a href="#">2020-09-25 18:47:36</a> | <a href="#">2020-10-21 18:00:02</a> | <a href="#">2020-10-21 17:59:47</a> | <a href="#">2020-10-21 17:59:47</a> | <a href="#">2020-10-22 23:00:00</a> | <a href="#">2020-07-24 18:43:00</a> | 2020-10-21 18:00:12 | completato           | <input type="checkbox"/> |
| <a href="#">2020-09-25 18:47:36</a> | <a href="#">2020-10-21 06:52:02</a> | <a href="#">2020-10-21 06:52:41</a> | <a href="#">2020-10-21 06:52:41</a> | <a href="#">2020-10-21 23:00:00</a> | <a href="#">2020-07-24 18:43:00</a> | 2020-10-21 06:52:59 | completato           | <input type="checkbox"/> |
| <a href="#">2020-09-25 18:47:36</a> | <a href="#">2020-10-20 18:26:02</a> | <a href="#">2020-10-20 18:26:19</a> | <a href="#">2020-10-20 18:26:19</a> | <a href="#">2020-10-21 23:00:00</a> | <a href="#">2020-07-24 18:43:00</a> | 2020-10-20 18:26:37 | completato           | <input type="checkbox"/> |
| <a href="#">2020-09-25 18:47:36</a> | <a href="#">2020-10-20 09:47:03</a> | <a href="#">2020-10-20 09:47:05</a> | <a href="#">2020-10-20 09:47:05</a> | <a href="#">2020-10-20 23:00:00</a> | <a href="#">2020-07-24 18:43:00</a> | 2020-10-20 09:47:21 | completato           | <input type="checkbox"/> |
| <a href="#">2020-09-25 18:47:36</a> | <a href="#">2020-10-19 18:13:02</a> | <a href="#">2020-10-19 18:13:09</a> | <a href="#">2020-10-19 18:13:09</a> | <a href="#">2020-10-20 23:00:00</a> | <a href="#">2020-07-24 18:43:00</a> | 2020-10-19 18:13:21 | completato           | <input type="checkbox"/> |
| <a href="#">2020-09-25 18:47:36</a> | <a href="#">2020-10-19 09:51:02</a> | <a href="#">2020-10-19 09:51:08</a> | <a href="#">2020-10-19 09:51:08</a> | <a href="#">2020-10-19 23:00:00</a> | <a href="#">2020-07-24 18:43:00</a> | 2020-10-19 09:51:59 | completato           | <input type="checkbox"/> |

RTO online  
Thu 1 Oct 15:33:23

Visualizza ed Edita altri parametri | Visualizza e produci Pianificazione Consolidata da Pianificazione Ipotetica del 01-10-2020 15:32:05 | Non c'è una Pianificazione Consolidata attiva

Elenco esecuzioni pianificazioni | Elenco esecuzioni pianificazione in produzione | Avvia Pianificazione

Ultima data di aggiornamento parametri (TabPar): 25-09-2020 18:47:36  
Ultima data di aggiornamento dati da DCS (OPC-UA): 01-10-2020 15:33:02  
Ultima data di aggiornamento dati da amministrazione (AS400): 22-09-2020 14:51:06  
Ultima data di aggiornamento dati da pianificazione vendite ipotetica (AS400): 01-10-2020 15:32:05  
Ultima data di aggiornamento dati da pianificazione vendite consolidata (AS400): 01-10-2020 09:32:54  
Ultima data di aggiornamento dati da pianificazione energia h24 (PUN): 01-10-2020 23:00:00  
Ultima data di aggiornamento altri parametri: 24-07-2020 18:43:00

Salva Parametri

### Elenco Parametri Iniziali Algoritmo RTO SODA4.0

(effettuare cambiamenti che saranno utilizzati dalla prossima esecuzione)

5 days (N° di giorni su cui si vuole fare la pianificazione) [-]

1 alpha\_eco (Peso che decide l'importanza relativa di Stock e PUN nella funzione obiettivo) [-]

0.31 Cl2\_HCl32 (Cl2 consumato per ton di prodotto) [ton Cl2/ton HCl32]

297.54 MAX\_HCl32\_s (Massimo stock HCl32) [ton]

- **HTML pages can**
  - be dynamically generated from the Proc.Logic / IoT App
  - provide forms to produce data to the Proc.Logic / IoT App, also including interactive elements
  - collect file from users, and produce files to web and to the system
  - have CSS and AJAX controls



# From IoT App to generate HTML pages, forms

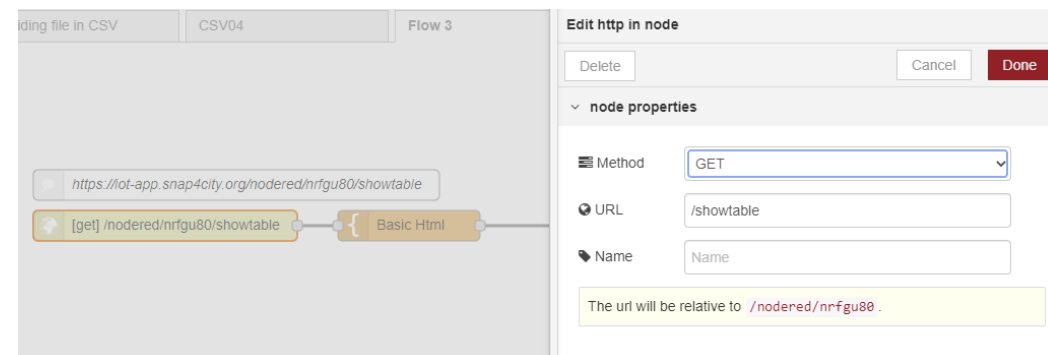
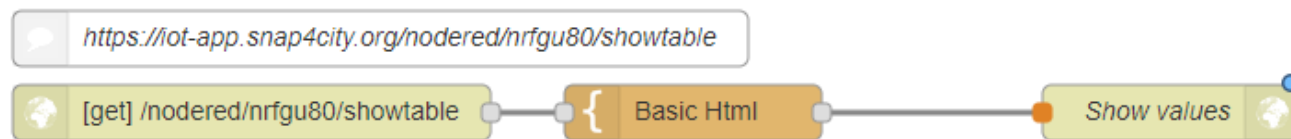

```

<html>
<style>table, th, td { border:1px solid black;}</style>
<head></head>
<body>
<h1>This is a table</h1><table style="width:100%">
  <tr>
    <th>Person 1</th>  <th>Person 2</th>  <th>Person 3</th>
  </tr>
  <tr>
    <td>Emil</td>  <td>Tobias</td>  <td>Linus</td>
  </tr>
  <tr>
    <td>16</td>  <td>14</td>  <td>10</td>
  </tr>
</table>
</body> </html>
  
```

Edit "HTTP IN NODE" as above, also to get the ID of your IoT APP.  
The ID is used in the URL of the generated page

| Person 1 | Person 2 | Person 3 |
|----------|----------|----------|
| Emil     | Tobias   | Linus    |
| 16       | 14       | 10       |

# HTML & Tables on Dashboards

- HTML page can expose forms to collect data for the IoT App.
- The table can be
  - constructed with the style you prefer according to HTML, CSS, etc.
  - dynamically generated on the basis of the values you collect/generate, receive, recover from storage in the flow
  - updated by send a message on the node
  - show on Dashboard by using the link (URL) into an External Content Widget
- In alternative there is to the Widget Table with less flexibility

# From IoT App to API Get

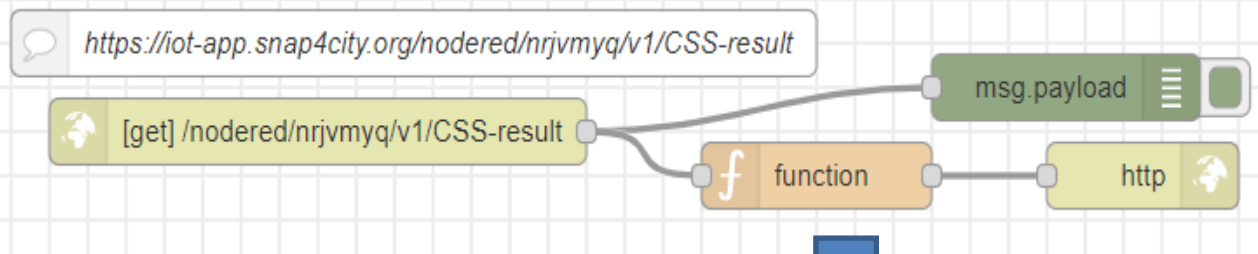

Function receives:

```
{"prova": "1", "test": "mio"}
```

It can interpretes the REST call to provide at the next Node the result

The HTML page can be emebded into External Content widget of a dashboard

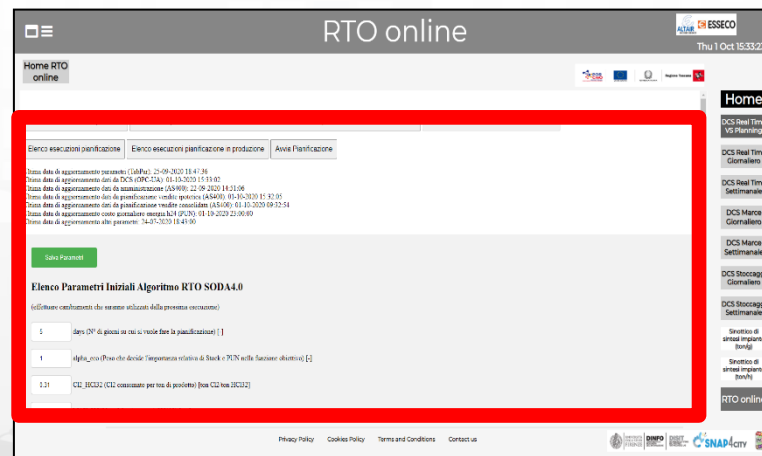

## Call on Browser:

<https://iot-app.snap4city.org/nodered/nrjvmyq/v1/CSS-result/?prova=1&test=mio>

Domain Prefix  
IoT App ID  
Your custom

TOP

# Visual Analytic vs Data Analytics: Client Side Business Logic Intelligence

FROM CITY DASHBOARD TO APPLICATIONS

FORGING & MANAGING OPEN AND FLEXIBLE WEB AND MOBILE APPS

IOT APPLICATIONS VS IOT EDGE

SNAP4CITY FOR BEGINNERS

SNAP4CITY ARCHITECTURE AND ECOSYSTEM. OPENED TO DEVELOPERS AND STAKEHOLDERS

TWITTER VIGILANCE SOCIAL MEDIA ANALYSIS

SNAP4CITY AND KM4CITY PROJECTS

IOT/IOE DEVICES AND NETWORKS

DATA ANALYTICS, BUSINESS INTELLIGENCE, WEATHER SIMULATION

HOW TO ADOPT SNAP4CITY, AND OUR ROADMAP

IOT APPLICATIONS, THE LOGIC AND THE SMARTNESS

ADVANCED SMART CITY API, MICROSERVICES, SNAP4CITY API

SNAP4CITY THE VIEW OF THE ADMINISTRATORS

SNAP4CITY LIVING LAB FOR COLLABORATIVE WORK

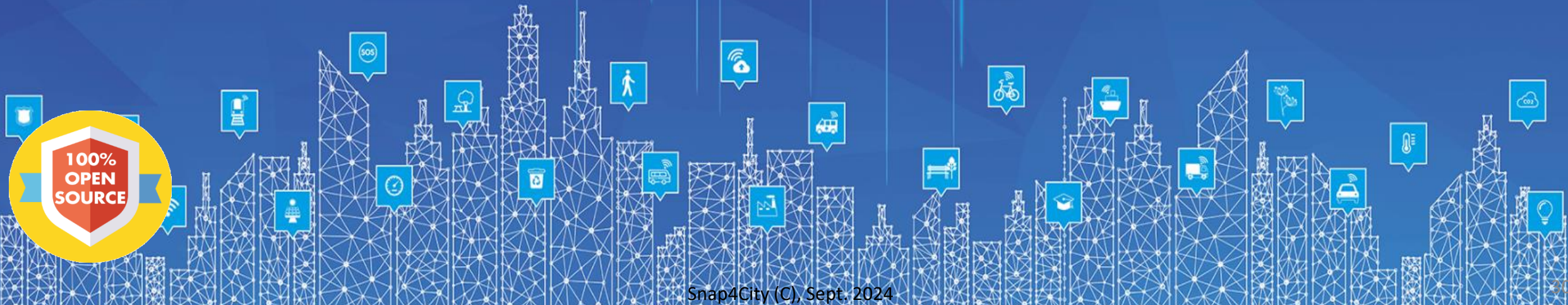

# Client Side Business Logic

<https://www.snap4city.org/download/video/ClientSideBusinessLogic-WidgetManual.pdf>



Powered by  
**SNAP4Tech**

## Client-Side Business Logic Widget Manual

### From Snap4City:

- We suggest you read <https://www.snap4city.org/download/video/Snap4Tech-Development-Life-Cycle.pdf>
- We suggest you read the TECHNICAL OVERVIEW:
  - <https://www.snap4city.org/download/video/Snap4City-PlatformOverview.pdf>
- slides go to <https://www.snap4city.org/577>
- <https://www.snap4city.org>
- <https://www.snap4solutions.org>
- <https://www.snap4industry.org>
- <https://twitter.com/snap4city>
- <https://www.facebook.com/snap4city>
- <https://www.youtube.com/channel/UC3TAO09EbNba8f2-u4vanda>

Coordinator: Paolo Nesi, [Paolo.nesi@unifi.it](mailto:Paolo.nesi@unifi.it)  
DISIT Lab, <https://www.disit.org>  
DINFO dept of University of Florence,  
Via S. Marta 3, 50139, Firenze, Italy  
Phone: +39-335-5668674



# How the Dashboards / Apps Exchange data (2024/8)

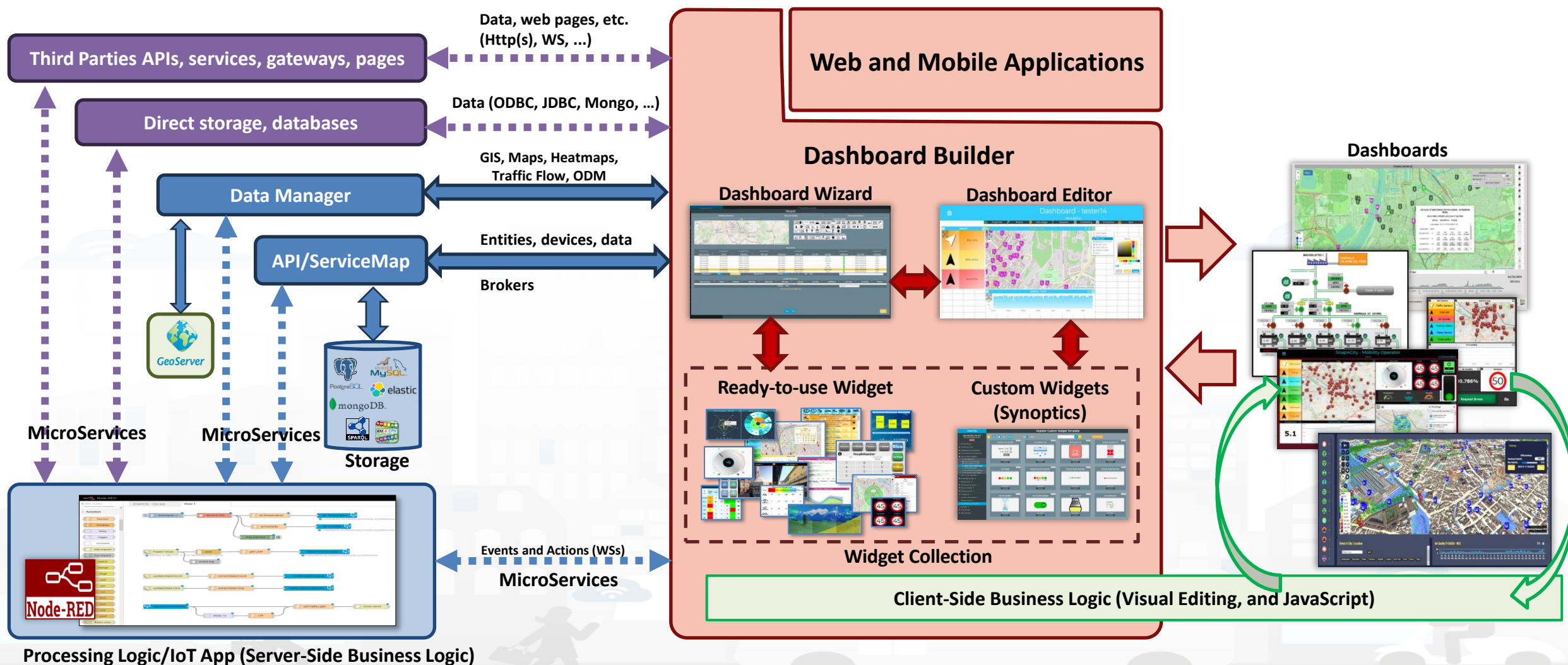

# Client Side Business Logic, CSBL

- solution to close the loop from user actions and effects on widgets directly on the client side, on the browser
- **Client-Side Business Logic, CSBL**, and **Server-Side Business Logics, SSBL**, may be present at the same time behind a Dashboard and thus behind a Business Intelligence / Smart Application
- CSBL the logic code is formalized in JavaScript only, while in SSBL the logic is formalized in Proc.Logic which is Node-RED plus some JavaScript.
- Developers that would like to develop CSBL have to be authorized, please ask to [snap4city@disit.org](mailto:snap4city@disit.org)
- When working in SSBL, widgets can be created
  - and edited from Node-Red Processing Logic.
  - also through the Dashboard Wizard

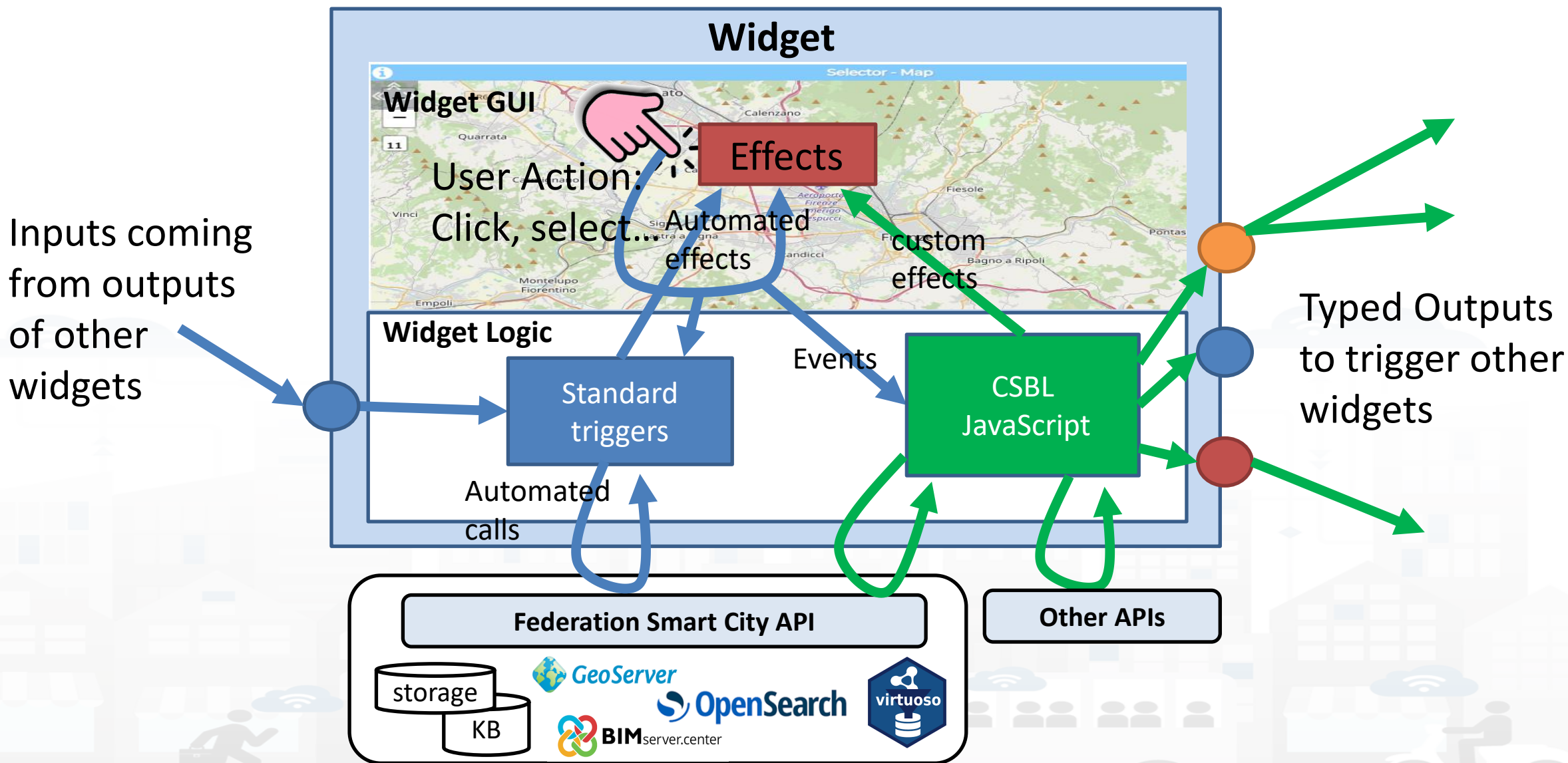



# Composition

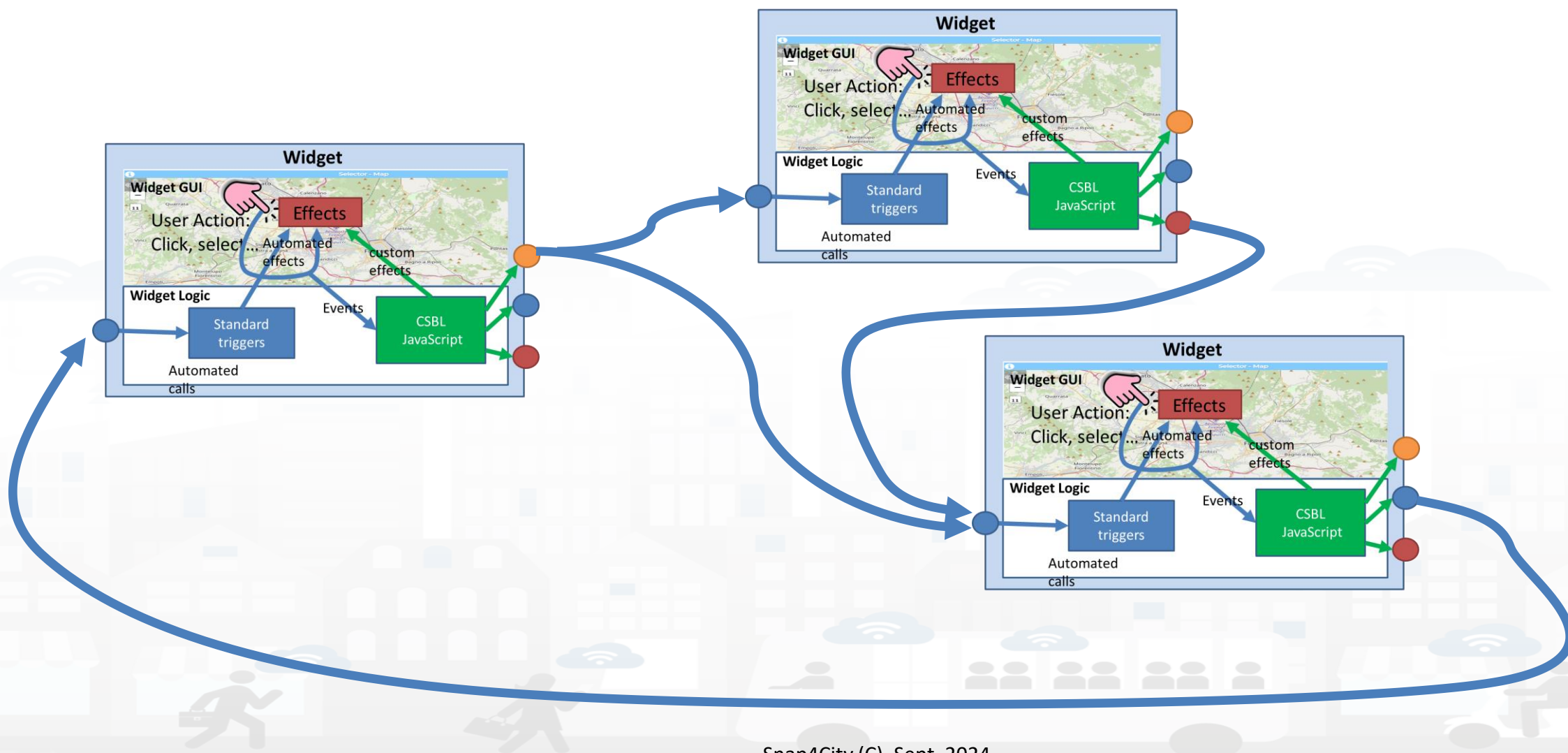

# Visual programming for CSBL is coming soon

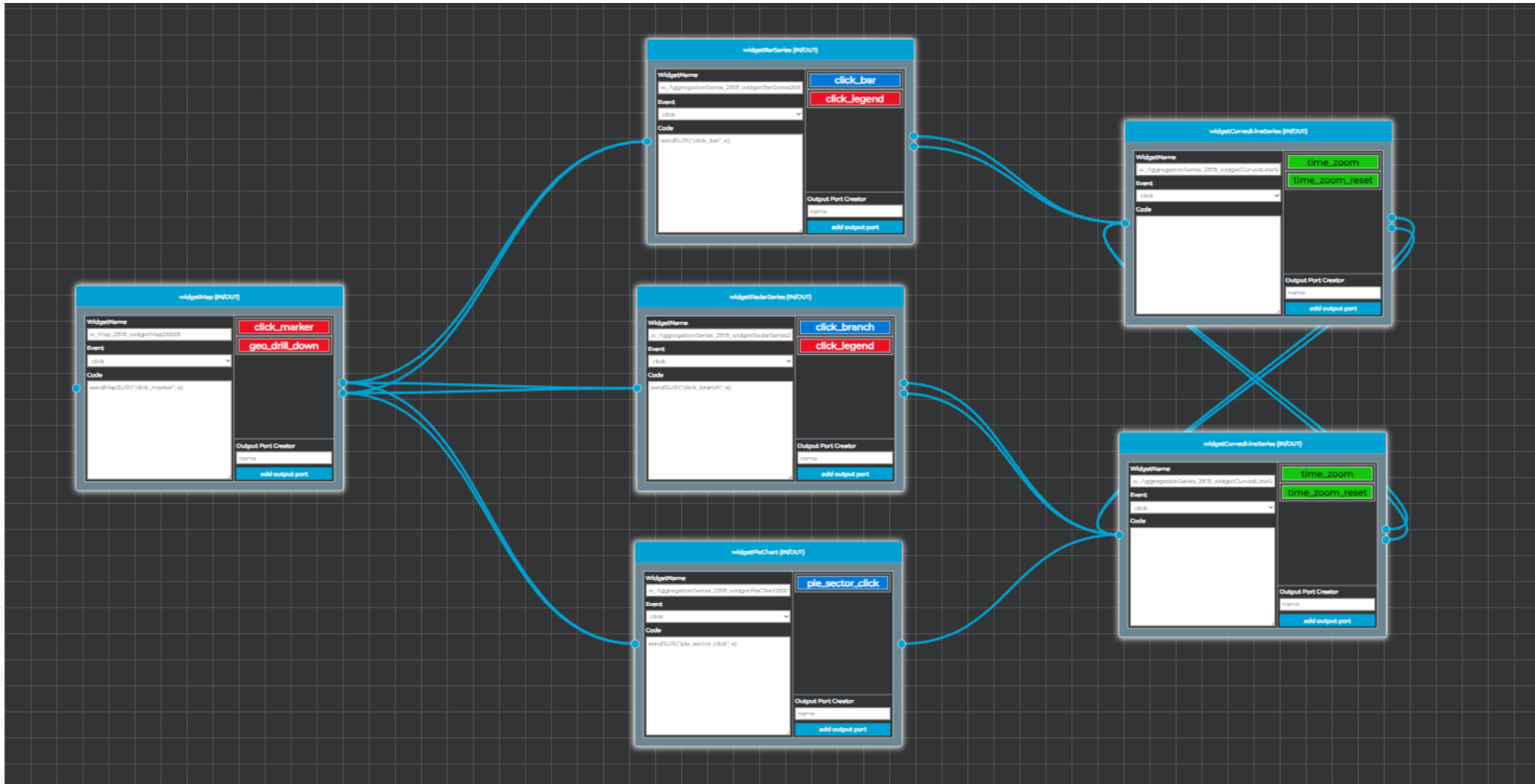

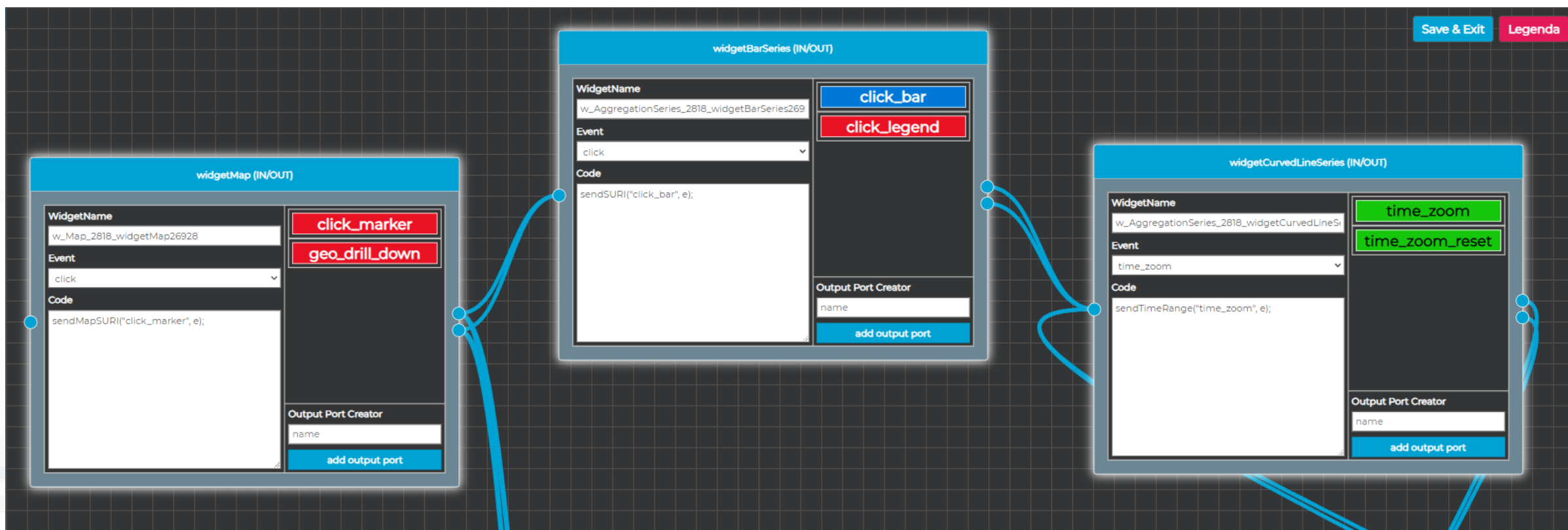

# User Actions, Triggers on Responder

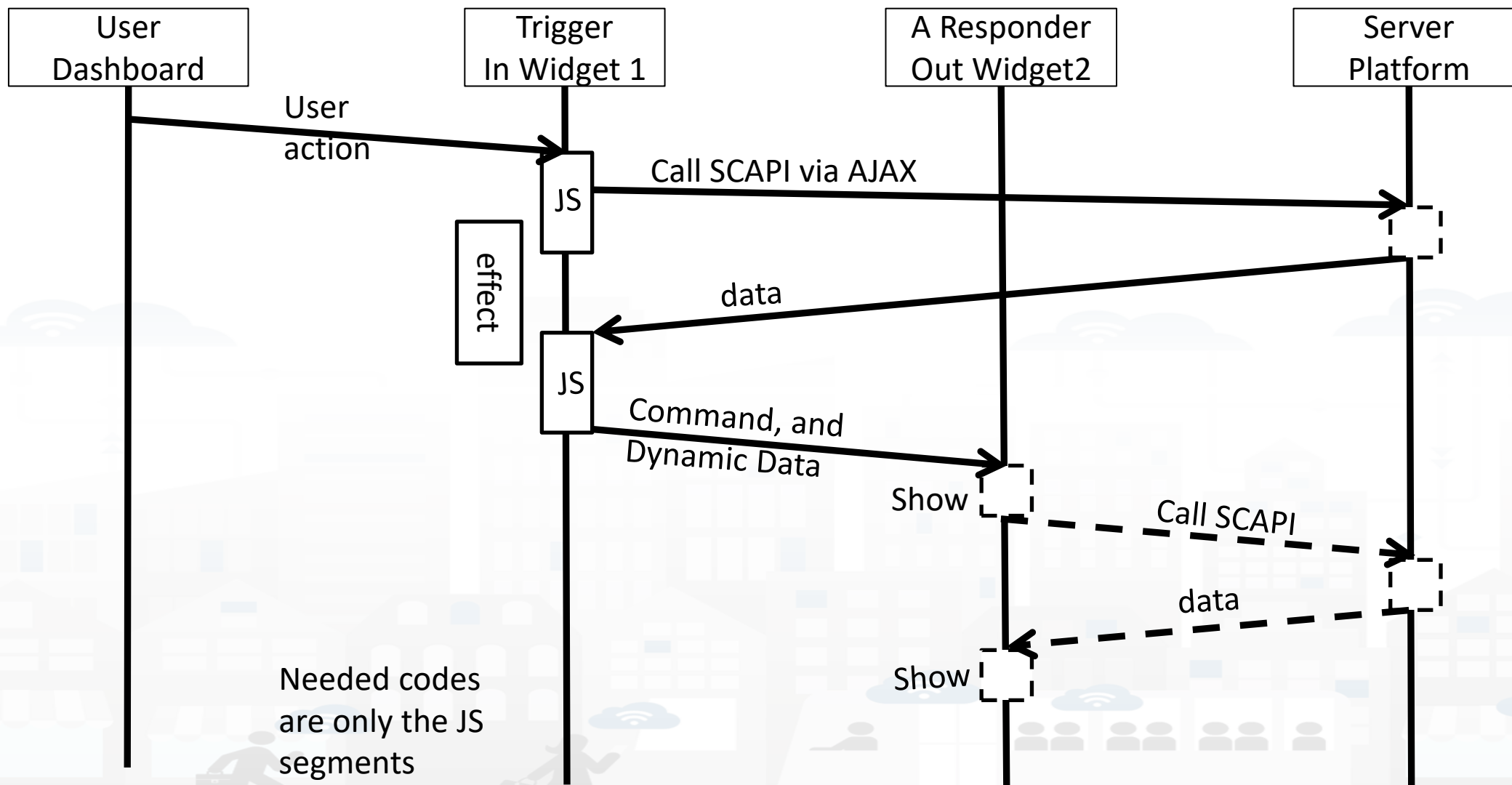

# User Actions, Triggers on Responder

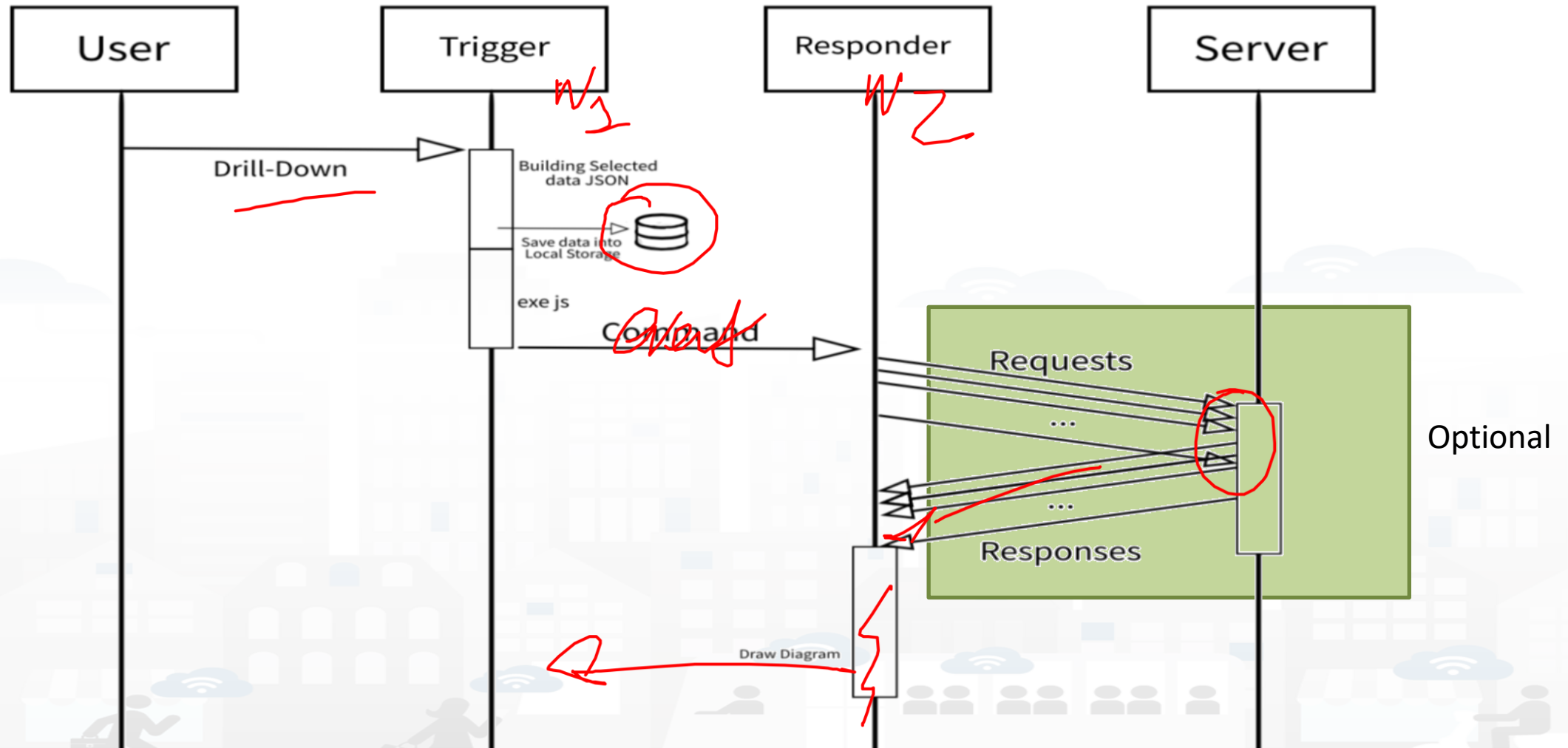

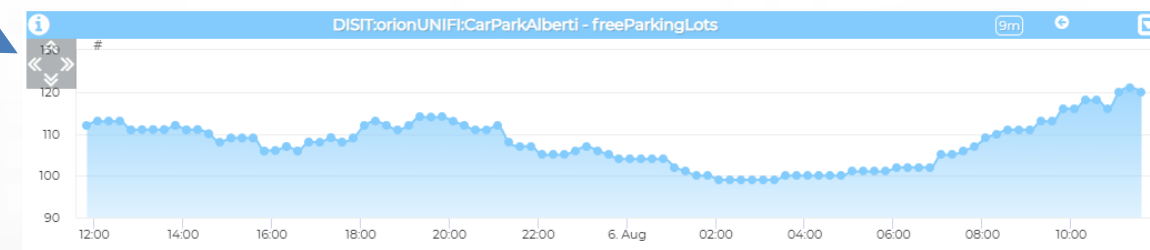
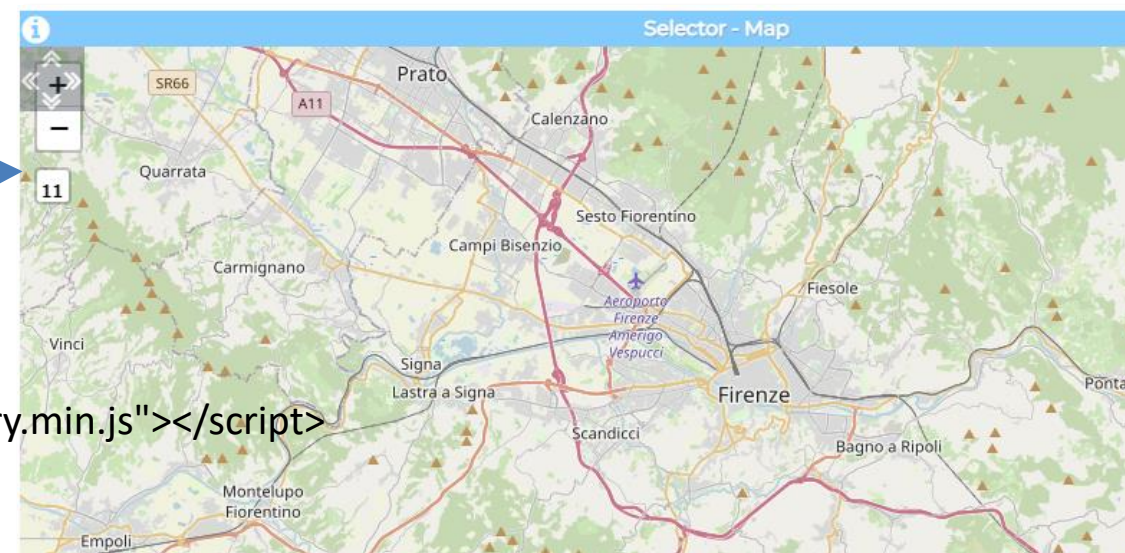

```
<html>
<head>
  <script src="https://ajax.googleapis.com/ajax/libs/jquery/1.10.1/jquery.min.js"></script>
  <script type='text/javascript'>
    .....
  </script>
</head>
<body>
  <h2>Trigger dashboard widgets from External Content iframe</h2>
  <div>
    <!-- <button onclick="showAlert()">Alert Button GP</button> -->
    <button id="triggerTTrend">Trigger data on Time-Trend</button>
    <button id="triggerMap">Trigger data on Map</button>
  </div>
</body>
</html>
```

# Trigger based

```

<script type='text/javascript'>
var showAlert;
var triggerTimeTrend;
var triggerMap;
$(document).ready(function () {
  showAlert = function () {
    var myText = "Test alert";
    alert (myText);
  }
  $('#triggerTTrend').click(function (event) {
    .....
    parent.$('body').trigger({ ..... });
  });
  $('#triggerMap').click(function (event) {
    .....
    parent.$('body').trigger({ ..... });
  });
});
</script>

```

## Enforcing HTML and JavaScript on MoreOptions of the External Content Widget

The screenshot shows the configuration interface for an external content widget. It is divided into three main sections:

- Metric and widget choice:** Contains fields for Widget category (Data viewer), Metric (NR\_a2874619\_ebd078), Widget name (w\_NR\_a2874619\_ebd078\_2573), Widget type (widgetExte, max 1 metrics), Context, Widget link (https://rttvhd.snap4city.org/), and Metric description.
- Generic widget properties:** Contains fields for Title (Florence Da), Background color (rgba(2)), Content font size, Content font color, Header color (rgba(5)), Header text color (rgba(2)), Period, Refresh rate (s), Height (41), Width (31), U/M, U/M position, Show header (Yes), and Font type (autosuggestion).
- Specific widget properties:** Contains fields for Widget mode (Web link), Enable fullscreen in new tab (Yes), Enable fullscreen in a popup (Yes), Zoom controls visibility (Always), Zoom factor (105%), and Zoom controls position (Top left).

At the bottom right, there is a text editor area with the following content:

```

<html>
<head>
<script
src="https://ajax.googleapis.com/ajax/libs/jquery/1.10.1/jquery.min.js"></script>
<script type="text/javascript">
var showAlert;
var triggerTimeTrend;
var triggerMap;
$(document).ready(function () {
showAlert = function () {

```

A blue arrow points from the 'Specific widget properties' panel to the JavaScript code on the left, indicating that the configuration is used to enforce HTML and JavaScript on the widget's content.

# Formalization of SSBL on In Widget More Options

- CK EDITOR

Modify widget

## Metric and widget choice

<b>Widget category</b>	Actuator
<b>Actuator target</b>	Personal apps
<b>Input from personal apps</b>	NR_caa95069_baa388
<b>Value type</b>	Testuale
<b>Start value</b>	{ "options": "3382", "selected": "" }
<b>Domain type</b>	
<b>Widget type</b>	widgetImpulseButton

## Generic widget properties

<b>Title</b>	Trigger Pie C	<b>Background color</b>	rgba(2
<b>Content font size</b>		<b>Content font color</b>	
<b>Header color</b>	rgba(5	<b>Header text color</b>	rgba(2
<b>Period</b>		<b>Refresh rate (s)</b>	
<b>Height</b>	10	<b>Width</b>	11
<b>U/M</b>		<b>U/M position</b>	
<b>Show header</b>	Yes	<b>Font type (autosuggestion)</b>	Auto

## Specific widget properties

<b>View mode</b>	Icon and text	<b>Button radius (%)</b>	
<b>Impulse mode</b>		<b>Button color</b>	rgba(214,2
<b>Button color</b>	rgba(214,2	<b>Button color on click</b>	rgba(214,2
<b>Symbol color</b>	rgba(0,0,0,	<b>Symbol color on click</b>	rgba(0,0,0,
<b>Text color</b>	rgba(0,0,0,	<b>Text color on click</b>	rgba(0,0,0,
<b>Text font size</b>	24	<b>Display font size</b>	24
<b>Display text color</b>	rgba(255,2	<b>Display text color on click</b>	rgba(255,2
<b>Display background color</b>	rgba(0,0,0,	<b>Display radius (%)</b>	
<b>Display width (%)</b>		<b>Display height (%)</b>	

**Enable CK Editor** yes

Here you can insert Javascript code to be executed in the widget. Please save your script by clicking on the save button on the bottom.

```
function execute() {
  $('body').trigger({
    type:
    "showPieChartFromExternalContent_w_AggregationSeries_2573_wi
dgetPieChart34123",
    eventGenerator: $(this),
    targetWidget:
    "w_AggregationSeries_2573_widgetPieChart34123",
    color1: "#e8a023",
    color2: "#9c6b17",
    widgetTitle: "Vehicle Flow from Impulse Button",
  });
}
```



# Trigger map

```
$('#triggerMap').click(function (event) {  
    let coordsAndType = {};  
    coordsAndType.eventGenerator = $(this);  
    coordsAndType.desc = "CarPark";  
    coordsAndType.query =  
    "https://servicemap.disit.org/WebAppGrafo/api/v1/?selection=43.64471;11.005751;43.89471;11.505751&categories=Car_park&maxResults=200&format=json&model=CarPark";  
    coordsAndType.color1 = "#ebb113";  
    coordsAndType.color2 = "#eb8a13";  
    coordsAndType.targets = "w_DISIT_orionUNIFI_CarParkAlberti_2573_widgetTimeTrend33703"; // the Time Trend Widget ID once pop up open  
    coordsAndType.display = "pins";  
    coordsAndType.queryType = "Default";  
    coordsAndType.iconTextMode = "text";  
    coordsAndType.pinattr = "square";  
    coordsAndType.pincolor = "#959595";  
    coordsAndType.symbolcolor = "undefined";  
    // coordsAndType.altViewMode = altViewMode;  
    coordsAndType.bubbleSelectedMetric = "";  
    parent.$('body').trigger({  
        type: "addSelectorPin",  
        target: "w_Map_2573_widgetMap33705", // the Time Trend Widget ID of the event performed on click  
        passedData: coordsAndType  
    });  
});
```

# Trigger Time trend

```
$('#triggerTTrend').click(function (event) {  
    parent.$('body').trigger({  
        type:  
        "showTimeTrendFromExternalContentGis_w_DISIT_orionUNIFI_CarParkAlberti_2573_widgetTimeTrend33703",  
        eventGenerator: $(this),  
        targetWidget: "w_DISIT_orionUNIFI_CarParkAlberti_2573_widgetTimeTrend33703",  
        range: "7/DAY",  
        color1: "#34eb6e",  
        color2: "#114a23",  
        widgetTitle: "Free Parking Lots data from External Content",  
        field: "freeParkingLots",  
        serviceUri: "http://www.disit.org/km4city/resource/iot/orionUNIFI/DISIT/CarParkPal.Giustizia",  
        marker: "",  
        mapRef: "",  
        fake: false  
    });  
});
```

# Synchronization Multiple Time Trends

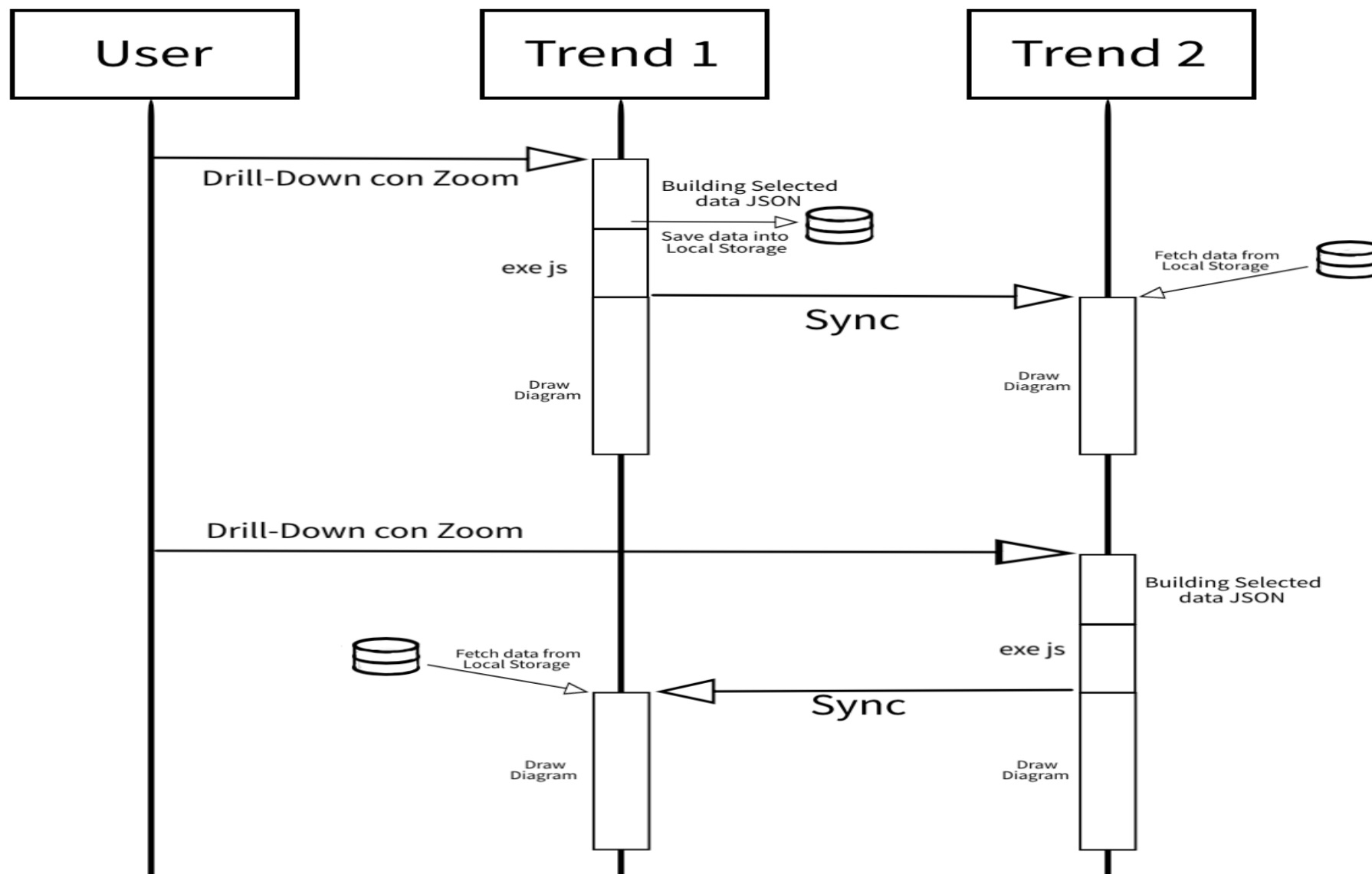

## Client Side Business Logic, CSBL

- **IN Widgets** are those that are prepared to receive some actions/commands from the Users. For example, a click on a button, a click on the map, etc. These IN Widgets can be regarded as Virtual Sensors.
- **OUT Widgets** are those that are prepared to provide some changes to be shown into the Users' interface. For example, a view of a barseries on some other data, a rendering of a time series, a rendering of a set of Entities on the map, etc. These OUT Widgets can be regarded as Virtual Actuators.
- **IN/OUT Widgets** are those that provide capabilities of both IN and OUT Widgets. For example, a map can receive an IN command about a selected PIN, and can receive an OUT command to show a selection of services, devices, etc. These IN/OUT Widgets can be regarded as Virtual Sensors/Actuators.

TOP

# *Client Side Business Logic Example*





## First BI Example

Mon 10 Apr 12:00:40



### Selector - Map

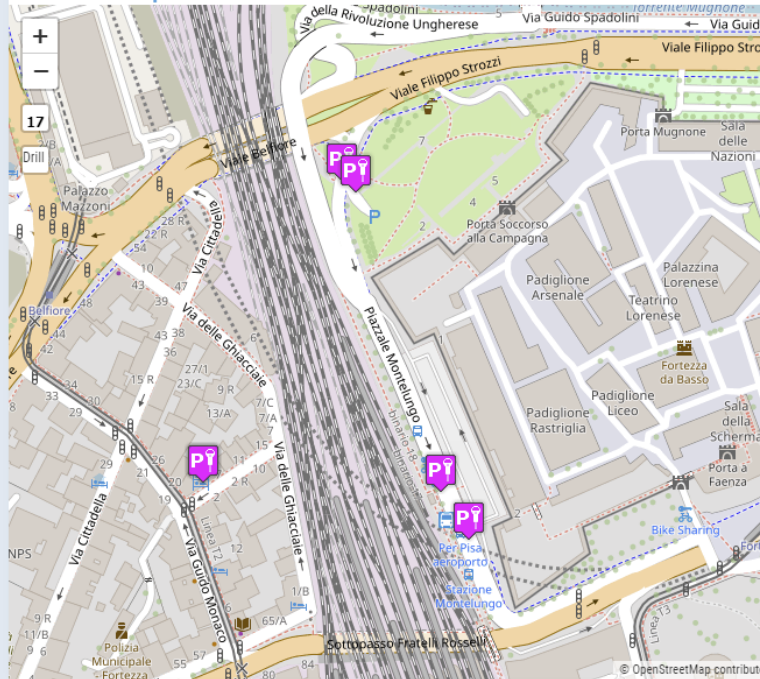

### Selector

- Car\_park
- metrotrafficsensor
- Air\_quality\_monitoring\_station
- Weather\_sensor

### Pie Chart

9m

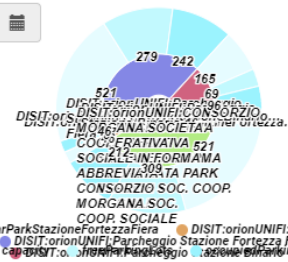

### Radar Series

4m

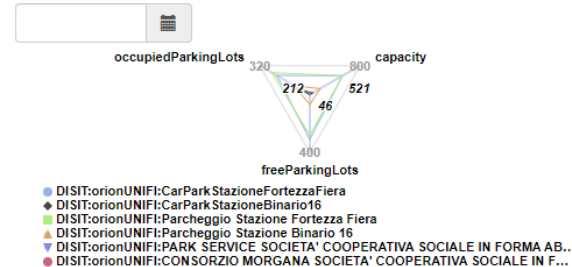

### Bar Series

4m

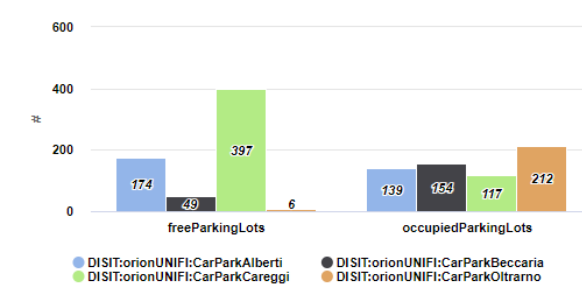

### Time Trend Comparison

4m

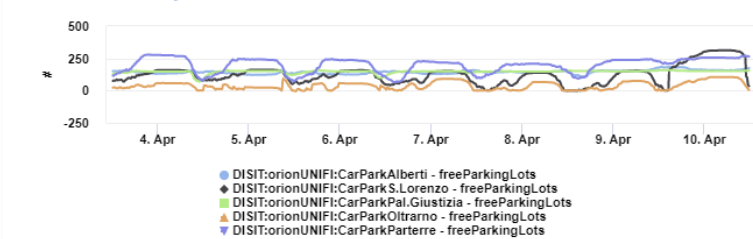

### Time Trend Comparison

4m

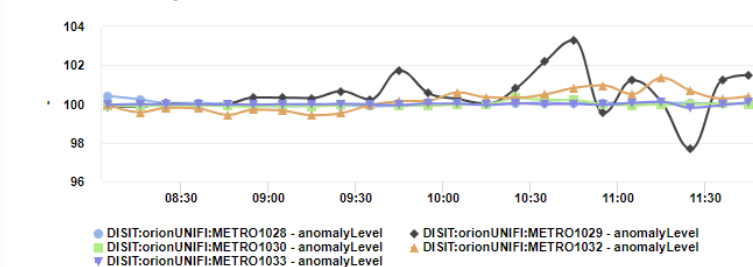

### Time Trend Comparison

4m

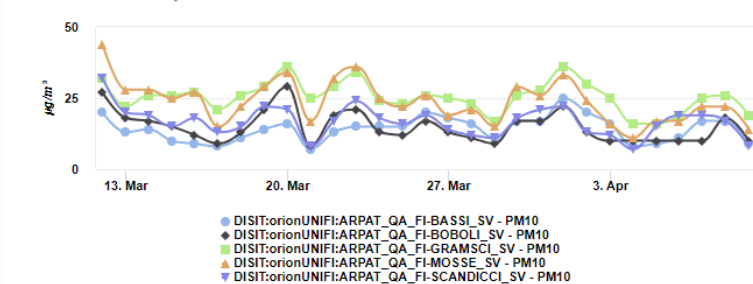



# Example: From Data Graphs to Graphs (drill down)

- 1) Click on the Donut element
- 2) The JavaScript CSBL on the Donut Widget will send commands to the programmed Widgets to focus on selection, as highlighted by the red arrows

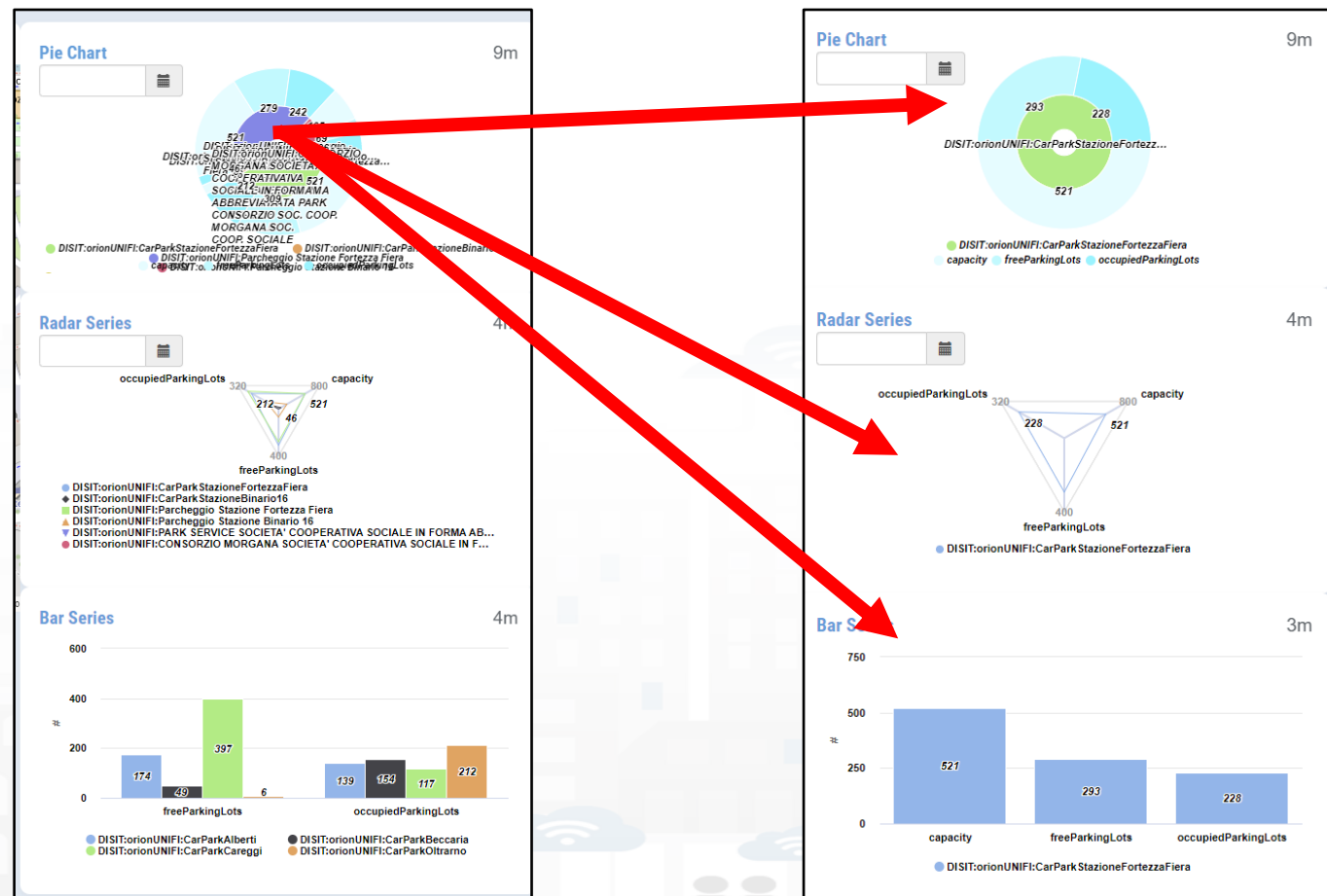



1) Click on the Legend of Bar Series

2) The JavaScript CSBL on the Bar Series will send commands to the programmed Widgets to remove the unselected devices, as highlighted by the red arrows



# Other Actions

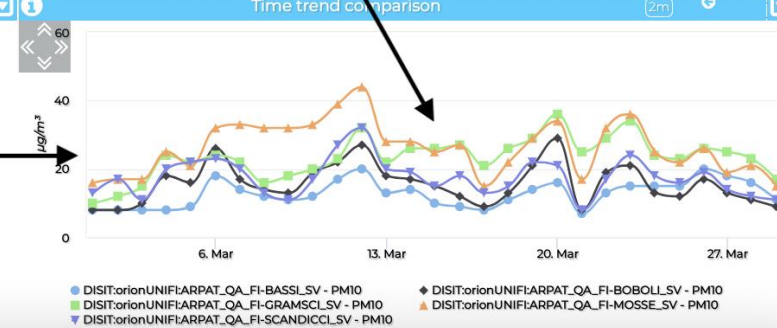
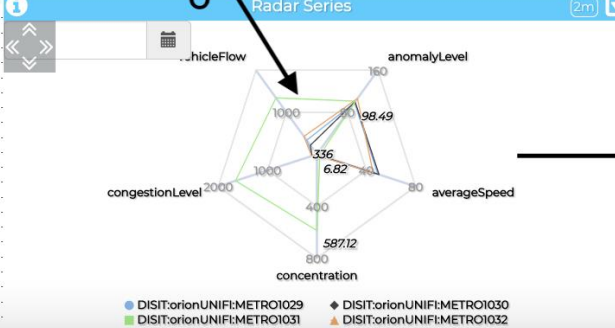
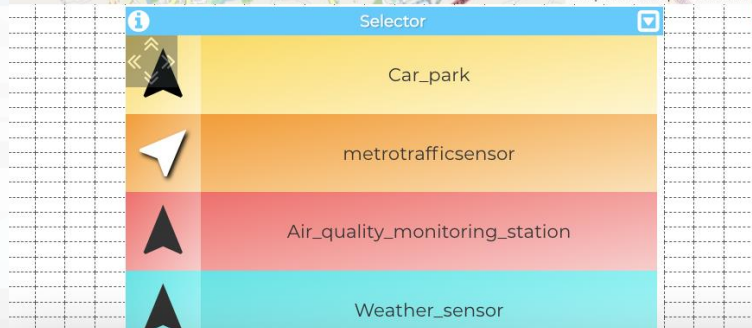
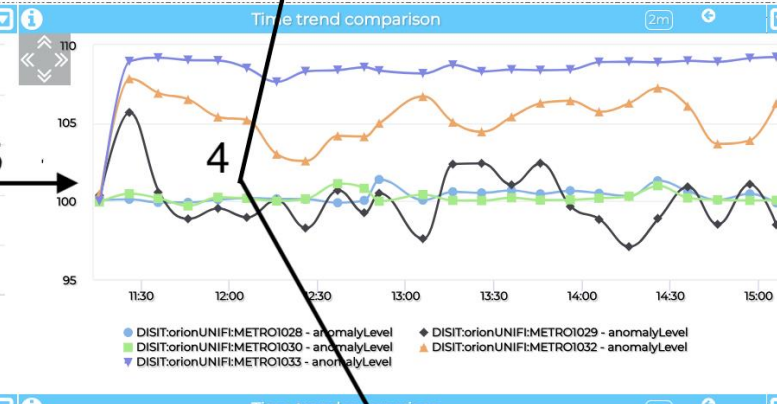
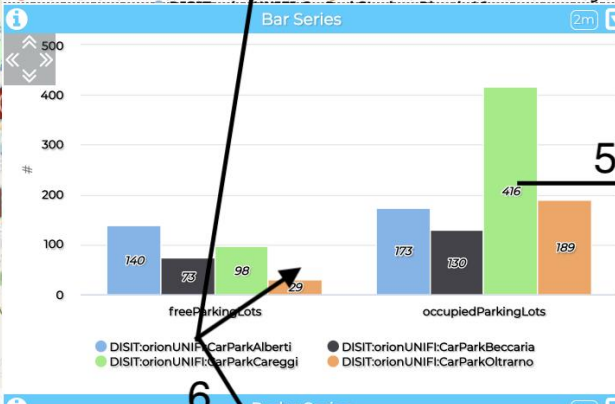
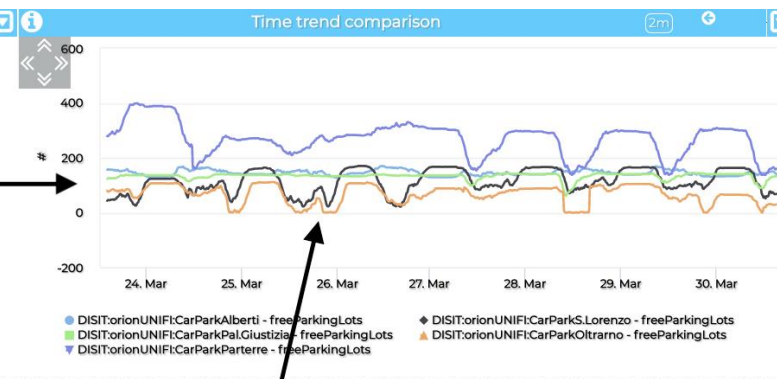
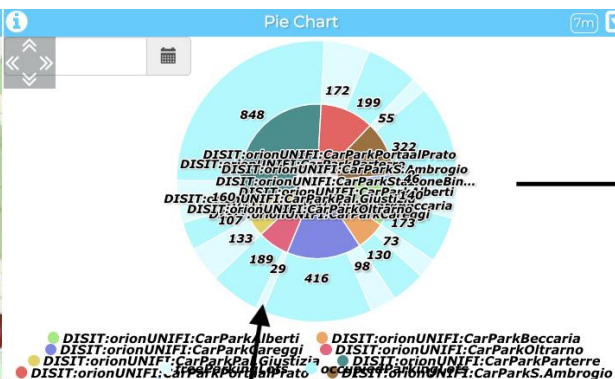
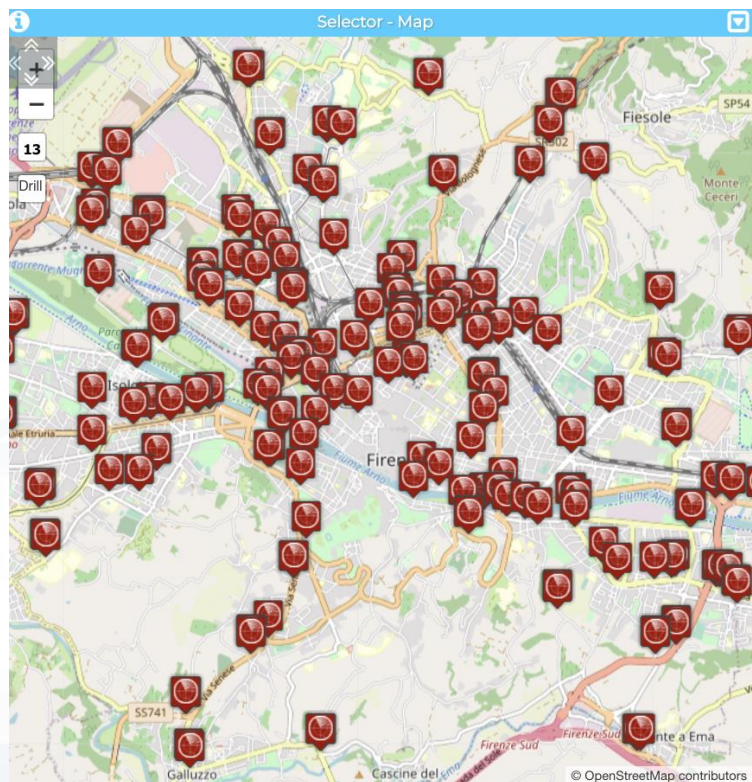

IN and IN/OUT Widgets	Users' Action Description and effects
widgetTimeTrend	Drill-Down on time interval selection (zoom), providing, SURI, value name, start and end time stamp
	Send Reset Drill-Down
	Click on a single time instant, providing time stamp, SURI and value name
widgetMap (multidatamap)	Click on a generic point on the map, providing coordinates (under development, currently it only works for SSBL)
	Click on a PIN, providing coordinates and ServiceURI of the clicked PIN
	Select the bounding box area shown on the map, and the zoom level in order to perform geographical Drill-Down on the entities (devices identified by SURIs, Points of Interest etc.) which are currently shown on map
widgetPieChart	Click on a sector that identifies the name of a metric, providing: value, timestamp, entity name (from which the SURI can be reconstructed) value name, value type and value unit
	click on a sector that identifies a device ID or MyKPI ID, providing: value, timestamp, entity name (from which the SURI can be reconstructed) value name, value type and value unit
	Click on legend, providing the status (e.g.: "checked" or "unchecked") of the metric/SURI which has been clicked (under development)
widgetBarSeries	Click on a bar, providing: value, timestamp, entity name (from which the SURI can be reconstructed) value name, value type and value unit
	Click on legend, providing the visibility status of each metric/SURI
widgetRadarSeries	Click on a radar axis related to a specific metric of a specific device, providing: value, timestamp, entity name (from which the SURI can be reconstructed) value name, value type and value unit
	Click on legend, providing the visibility status of each metric/SURI
widgetCurvedLineSeries (multi series)	Drill-Down on time interval selection (zoom), providing: start and end time stamp, and list of SURI. It is also possible to program the synchronization of multiple widgetCurvedLineSeries widgets.
	Click on a single time instant, providing: time stamp and list of objects including SURIs and related entity names and value names
	Click on legend, providing the visibility status of each metric/SURI
	Send Reset Drill-Down
widgetDeviceTable	Click on the action buttons, providing the action type, the corresponding SURI and a list of attributes with their corresponding values
widgetImpulseButton	Click on button as a trigger (no parameters are provided)
widgetOnOffButton	Click on button, providing the new status
widgetKnob	Drag on knob, providing the value selected on the knob
	Click on minus and plus action
widgetNumericKeyboard	Click on the confirm button, providing the numeric value typed on the keyboard
widgetEventTable	Click on the action buttons, providing the action type, the corresponding event SURI and the ordering criteria
widgetExternalContent	It can support HTML pages and SVG Synoptics, in addition to JavaScript, so that it can perform a wide range of actions that can be defined in the HTML/SVG/JS code by the users.

# Typical Triggered Events

- SURI, List of SURI
  - Variable: Value Name (or metric)
- DateTime: date and time instant
- DateTime Interval: fromdatetime, todatetime
- ResetCommand
- GPS Coordinates, Bounding Box: a couple of coordinates
- Action (status | value)
- Etc.



OUT and IN/OUT Widgets	Commands which are ready to be executed from Widgets according to JavaScript in some IN Widget
widgetPieChart	Receive a JSON containing a list of SURJ, metric names and/or values, and show their corresponding values on a Pie Chart graph.
widgetRadarSeries	Receive a JSON containing a list of SURJ, metric names and/or values, and show their corresponding values on a Radar/Kiviati graph.
widgetBarSeries	Receive a JSON object containing a list of SURJ, metric names and/or values, and show their corresponding values on a Bar graph.
widgetSingleContent	<ul style="list-style-type: none"> <li>Receive a SURJ and a metric name, or a value, or a text string, and show the corresponding value.</li> <li>Receive and show a HTML/JS page</li> </ul>
widgetSpeedometer	Receive a SURJ and a metric name, or a value, and show the corresponding value on a speedometer graph.
widgetGaugeChart	Receive a SURJ and a metric name, or a value, and show the corresponding value on a gauge graph.
widgetTimeTrend	<p>Receive a SURJ and a metric name, or a value, and show the corresponding time-series on a line, spline, area or stacked area graph.</p> <p>Receive reset zoom</p>
widgetTable	<p>Receive a JSON containing a list SURJ, metric names and/or values, and show the corresponding time-series on a HTML static table.</p> <p>Receive start datetime, end datetime without change sources IDs</p>
widgetCurvedLineSeries	<p>Receive a JSON containing a list of SURJ, metric names and/or values, and show the corresponding time-series on a line, spline, area or stacked area graph.</p> <p>Receive start datetime, end datetime without change sources IDs</p> <p>Receive reset zoom</p>
widgetDeviceTable	Receive a JSON containing a list of SURJ representing IoT devices, and show their related attributes and values on an interactive table which provides action buttons.
widgetEvent	Receive a JSON containing a list of SURJ representing events as virtual devices, and show their related attributes (e.g., start and end date) and values on an interactive table which provides action buttons.
widgetMap	Receive a JSON containing a list of SURJ or entities (such as heatmaps, categories of Points of Interest etc.) and show them on an interactive map as clickable markers, dynamic SVG pins, traffic flows, heatmaps etc.
widgetOnOffButton	Receive and show a value representing the status
widgetKnob	Receive and show a value
widgetNumericKeyboard	Receive and show a value

*Example*

# Typical commands received

- SURI, List of SURI
  - Variable: Value Name (or metric)
- DateTime: date and time instant
- DateTime Interval: fromdatetime, todatetime
- ResetCommand
- MyKPI, List of MyKPI
- GPS Coordinates, Bounding Box: a couple of coordinates
- Action (status | value)
- Etc.

## CSBL: Useful Functions

functions on Actions JavaScript segments:

- Open a New Dashboard: **openNewDashboard()**
- Get parameters: **getParams()**

As a result, it is possible to activate in a new dashboard some actions on specific elements.

TOP

# *Develop: Client Side Business Logic Dashboards with Synoptics*





# Custom Widget / Synoptic / PIN Development

Inkscape editor on your computer



Create, save a Custom Widget in SVG

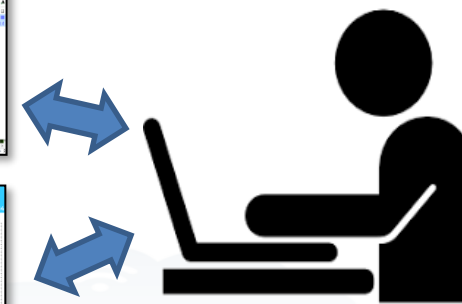

Create, save, load, delegate, grant access

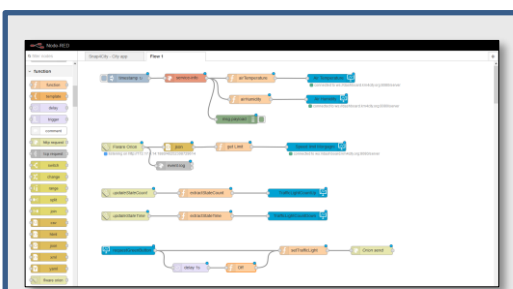

IOT Applications



Knowledge and Storage Data from the Field and City

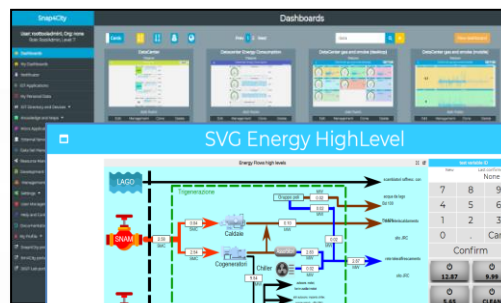
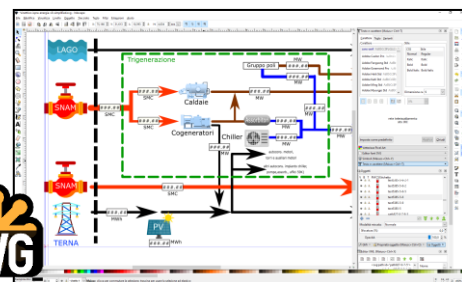
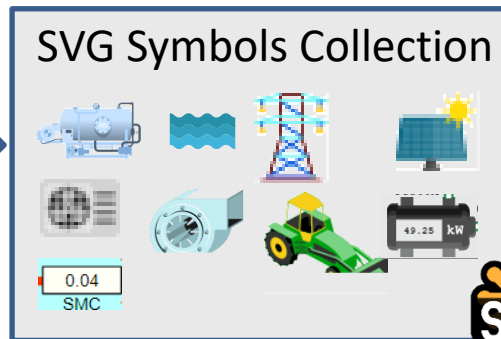

Public

Dashboard Collection

My Own Dash/App



1. Create and Load a Custom SVG
2. Select/Reuse an SVG
3. Make and Instance of Synoptic by Associate Variables with MyKPI or sensors
4. Create on Dashboard a Widget based on Synoptic HLT such as Ext. Srv.:

- <https://www.snap4city.org/synoptic/v2/synoptic.html?id=xxxx>

# Synoptic for Client Side Business Logic

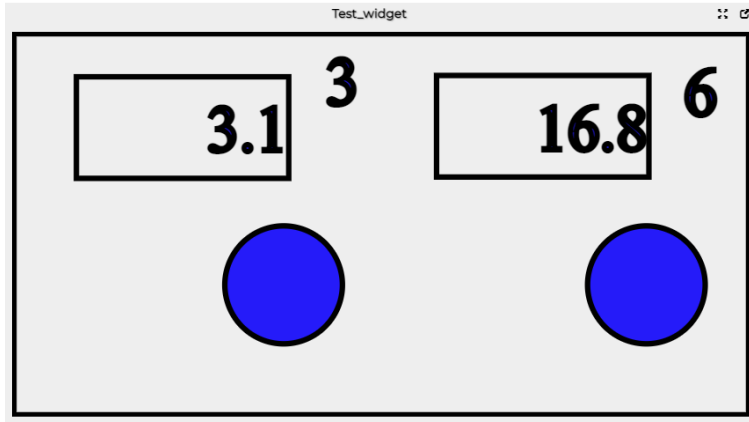

## In the SVG puts some code:

- at the button for example `OnClick()`, triggering an event
- at the text box to write the value in the box, for example:

```
TextBoxWrite3(.....)  
TextBoxWrite6(.....)
```

In the JavaScript of the External Content Widget hosting the SVG html code

The programmer can:

-- exploit the functions

```
TextBoxWrite3(.....)
```

```
TextBoxWrite4(.....)
```

-- receive the Triggered event and

write a JavaScript with a corresponding action

*The same SVG may have some elements working with respect to Server, IoT App, etc., and also with Client Side Business Logic*

# svg\_embed1

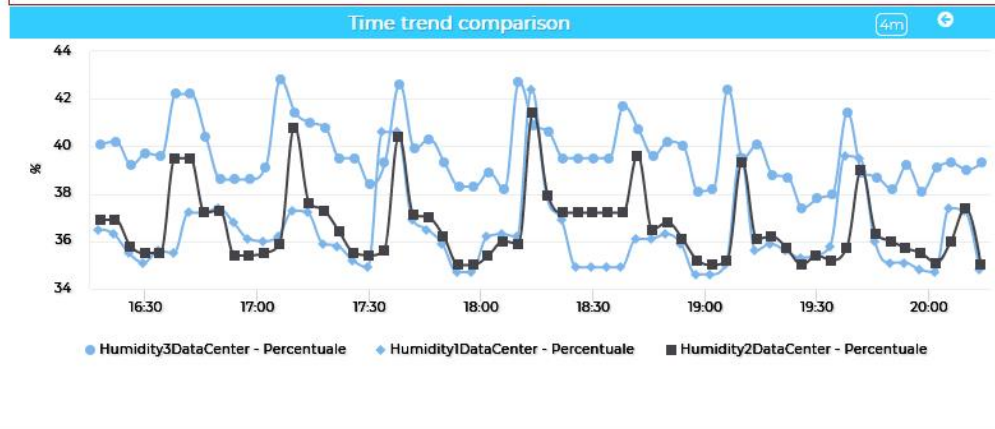
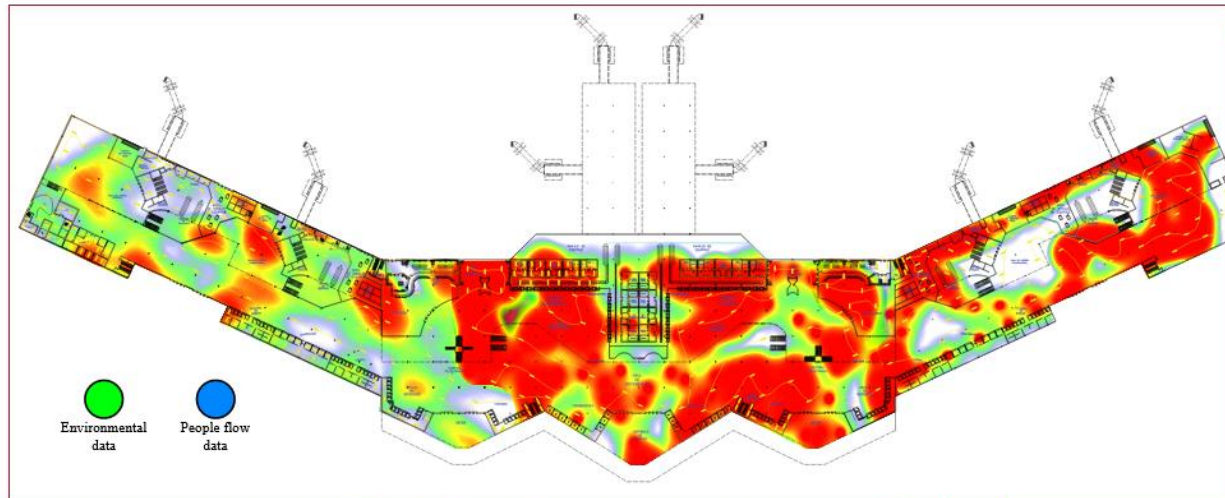

button1

button1



# Semantic Reasoning on Smart Applications

- Dashboards have relationships with

- Org. at which they belong
- Widgets with
  - data they use, and each of which
    - is connected with the Knowledge Base
    - May be: device, kpi, etc.
- IoT Apps with
  - Data they use
  - Data Analytic
  - Widget they control

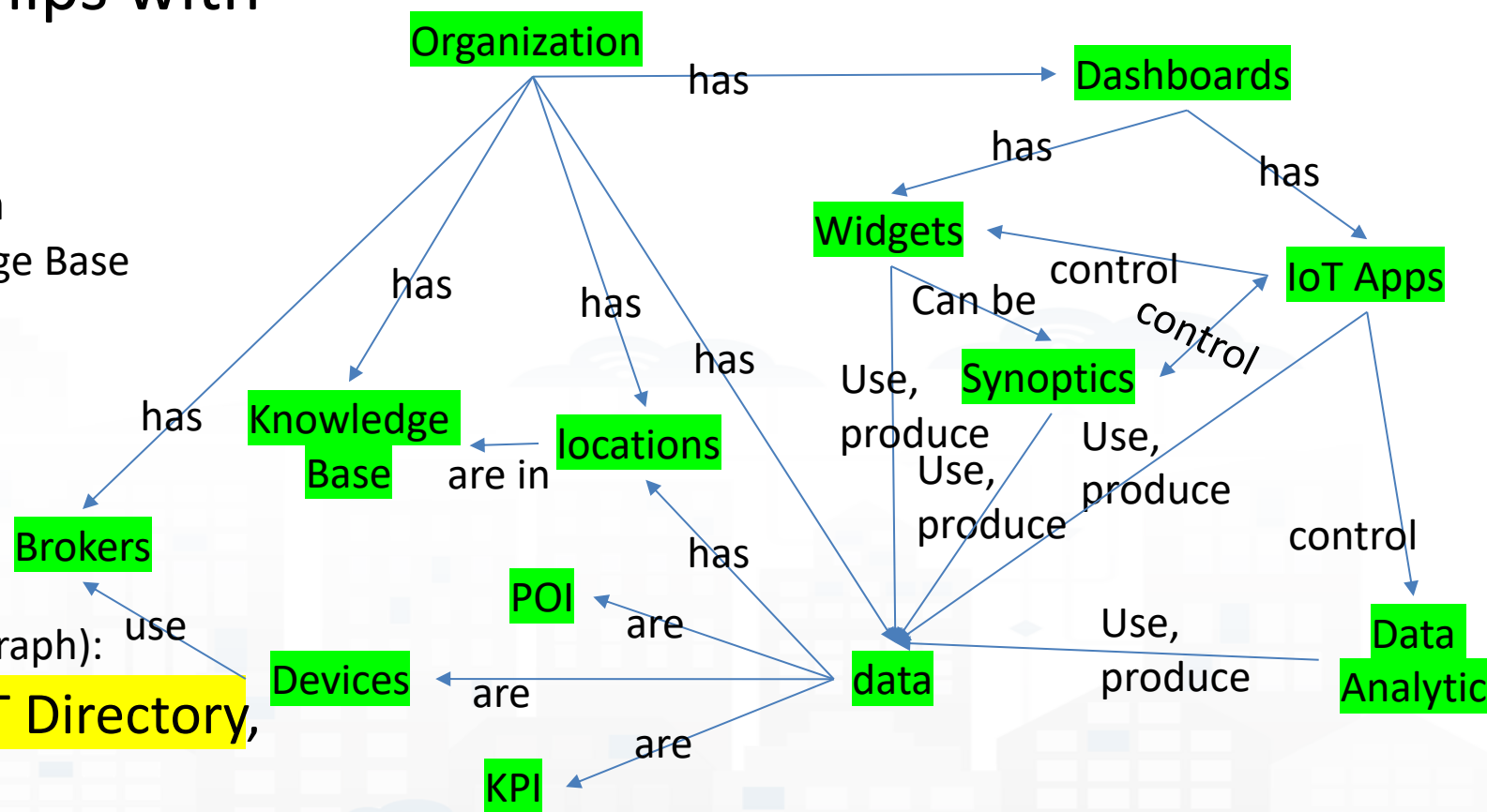

- Processes are (not in the simplified graph):

- Data, Broker, Data Analytic, IoT Directory, Device, IoT App, UserInterface
- owned, and delegated in some manner from the owner to other users

### Snap4City

User: roottooladmin1, Org: DISIT  
Role: RootAdmin, Level: 7

[LOGOUT](#)

- My Snap4City.org
- Tour Again
- ダッシュボード
- Dashboards (Public)**
- My Dashboards in All Org.
- Dashboards of My Organization
- My Dashboards in My Organization
- My Data Dashboard Dev Kibana
- My Data Dashboard Kibana
- Extra Dashboard Widgets

## Dashboards (Public by (ORG))

Cards [Sort icons] [Refresh] [Share]

Prev 1 Next

Venaria [Search] [Close]

#### Monitoring Cross Road Venaria

IOT apps

testaxisvenaria: Private - DISIT

Edit Management Clone Delete

#### Monitoring Cross Road Venaria - (AXIS Cam...

Passive

testaxisvenaria: Public - (DISIT)

Edit Management Clone Delete

## Management

- Ownership
- Visibility
- Delegations
- Group Delegations
- Accesses Trends
- Structure**
- Organization

### Monitoring Cross Road Venaria - (AXIS Camera)

Change ownership

New owner username  Confirm

*New owner username can't be empty*

Close

# Dashboard Structure and Components

## 4 Widgets

- Button
  - It is the image
- Curved LineSeries
  - .... Set of data....
- Curved LineSeries
  - ....set of data...
- External Content
  - With synoptic

The screenshot shows the 'Management' section of the SNAP4CITY interface. It features a navigation bar with tabs: Ownership, Visibility, Delegations, Group Delegations, Accesses Trends, Structure, Organization, and Thumbnail. A 'Link to Graph' button is visible. The main content area displays the 'Dashboard Hierarchy' for a specific dashboard: 'Monitoring Cross Road Venaria - (AXIS Camera)'. This hierarchy lists three widgets and their associated data sources and actions:

- Widget: Trajectories legenda - (widgetButton)**
  - Use Data:
- Widget: Number of Trajectories per hour - (widgetCurvedLineSeries)**
  - Use Data:
    - sensor: CrossVenaria2VehicleFlowTrajectoriesV2
    - Query: <http://www.disit.org/km4city/resource/iot/orionUNIFI/DISIT/CrossVen...>
    - Link to Data Inspector
    - Link to Graph log
    - Link to Servicemap
- Widget: In out computations and totals per hour - (widgetCurvedLineSeries)**
  - Use Data:
    - sensor: VenariaConteggio
    - Query: <http://www.disit.org/km4city/resource/iot/orionUNIFI/DISIT/VenariaC...>
    - Link to Data Inspector
    - Link to Graph log
    - Link to Servicemap
- Widget: Venaria Street Cross - per hour - (widgetExternalContent)**
  - Use Data:
    - Query: <https://www.snap4city.org/synoptics/v2/synoptic.html?id=135648299>
    - Link to Data Inspector (root)
    - Link to Graph log

# For All Dashboard owners: Graph and Structure

- Go on Dashboard Management

**Management**

Ownership | Visibility | Delegations | Group Delegations | Accesses Trends | **Structure** | Organization | Thumbnail

Link to Graph

Dashboard Hierarchy

Dashboard: - Energy -

- **Widget:** N&period; of App Users - (*widgetSingleContent*)
- **Use Data:**
- **Widget:** bench-icon - (*widgetButton*)
- **Use Data:**
  - **Query:** <https://www.snap4city.org/dashboardSmartCity/view/index.php?iddasbo...>
  - **Link to Data Inspector (root)**
  - **Link to Graph log**
- **Widget:** Piazza Francia - (*widgetSingleContent*)
- **Use Data:**
  - **my-kpi:** 17057099
  - **Query:** <http://model.snap4city.org/17057099>
  - **Link to Data Inspector**
  - **Link to Graph log**

## LOGraph

Linked Open Graph

Show Endpoints | Show User Status | Hide Relations

Embed

CarCount

Identifier: <http://www.dinfo.org/km4city/resource/uri/CarCount>

Image:

Info: no other informations

Special Query: `SPIN:CarCount`  
`http://www.dinfo.org/km4city/resource/uri/CarCount`

QUERY: `SELECT * FROM SPIN:CarCount`

Type of relations

<input type="checkbox"/> Select all	<input type="checkbox"/> Deselect all	<input type="checkbox"/> Invert	<input type="checkbox"/> Hide all inverse
<input checked="" type="checkbox"/> expossibility	<input type="checkbox"/> hasDepiction		
<input checked="" type="checkbox"/> hasAttribute	<input checked="" type="checkbox"/> hasDashboard		
<input checked="" type="checkbox"/> hasSystemCapability	<input checked="" type="checkbox"/> hasWidget		
<input checked="" type="checkbox"/> implements	<input checked="" type="checkbox"/> observes		
<input type="checkbox"/> owl:sameAs	<input checked="" type="checkbox"/> rdf:type		
<input checked="" type="checkbox"/> rdfs:seeAlso	<input checked="" type="checkbox"/> useData		
<input checked="" type="checkbox"/> usedByWidget			





## Monitoring Cross Road Venaria - (AXIS Camera)

Wed 10 Nov 18:50:53

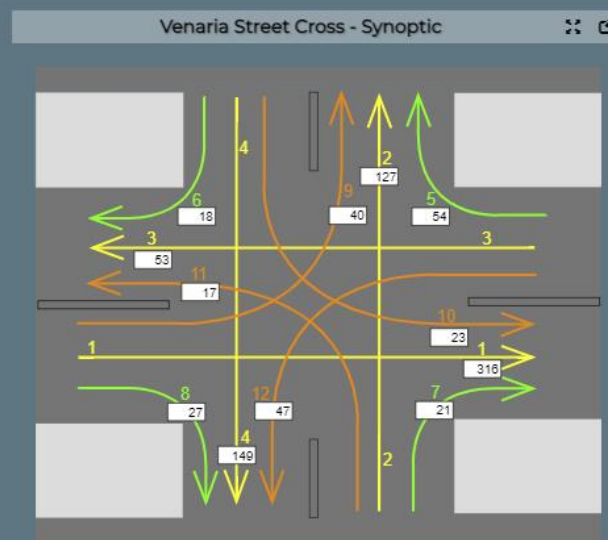
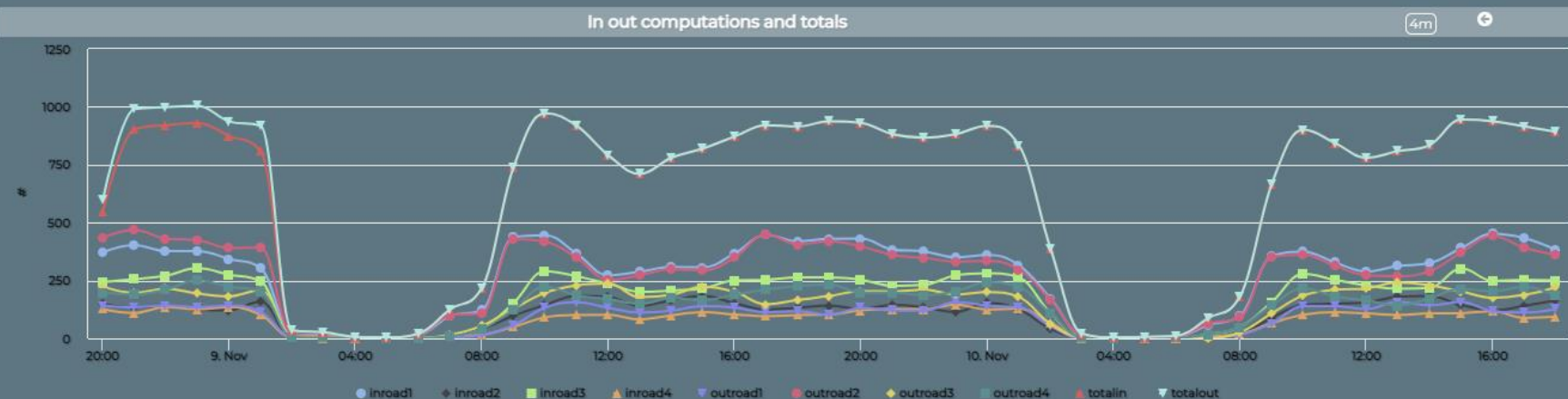
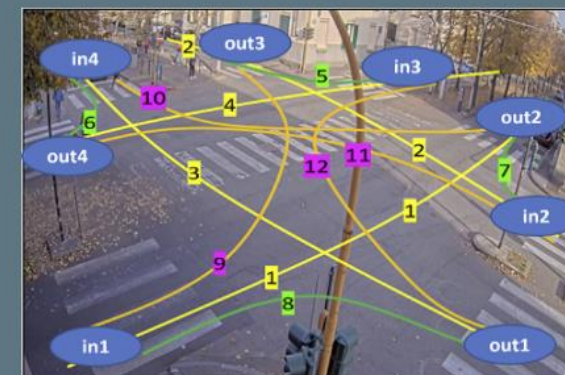
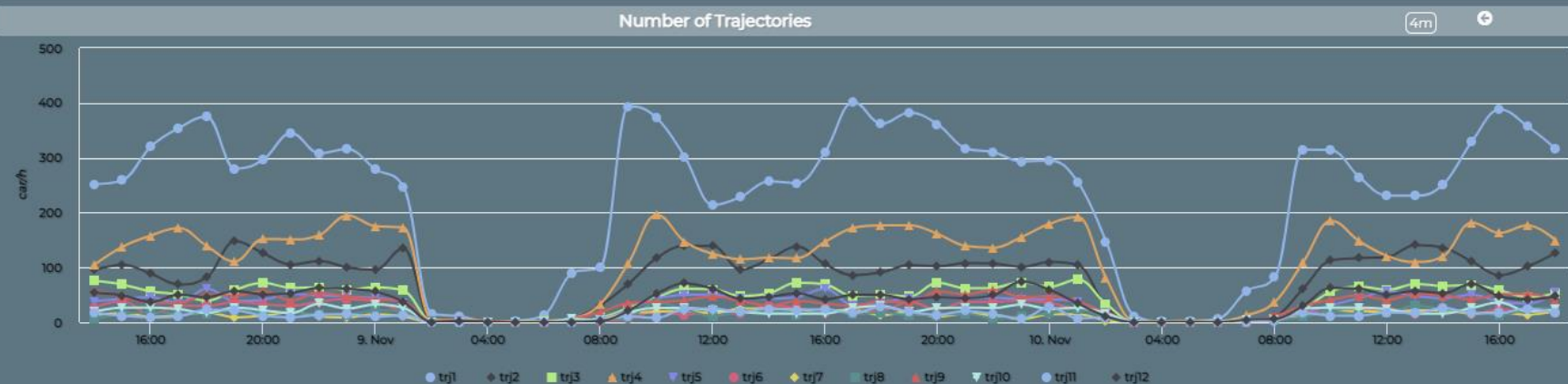

<https://www.snap4city.org/dashboardSmartCity/view/index.php?iddashboard=MzI5Ng==>

Linked Open Graph

Shown: 47  
Entities: 31  
Relations: 16

Show Endpoints Show User Status Hide Relations

Embed

- 
- 
- 
- 
- 
- 

CarCount Close

**Identifier:**  
http://www.disit.org/km4city/resource/iot/CarCount

**Image:**

**Info:**

no other informations

**Sparql Query:**

ENDPOINT:  
http://virtuoso-kb:8890/sparql

QUERY:  
SELECT ?subject ?property ?object

**Type of relations**

Select all Deselect all Invert  Hide all inverse

- exposedBy
- hasAttribute
- hasSystemCapability
- implements
- owl:sameAs
- rdfs:seeAlso
- usedByWidget
- foaf:depiction
- hasDashboard
- hasWidget
- observes
- rdf:type
- useData

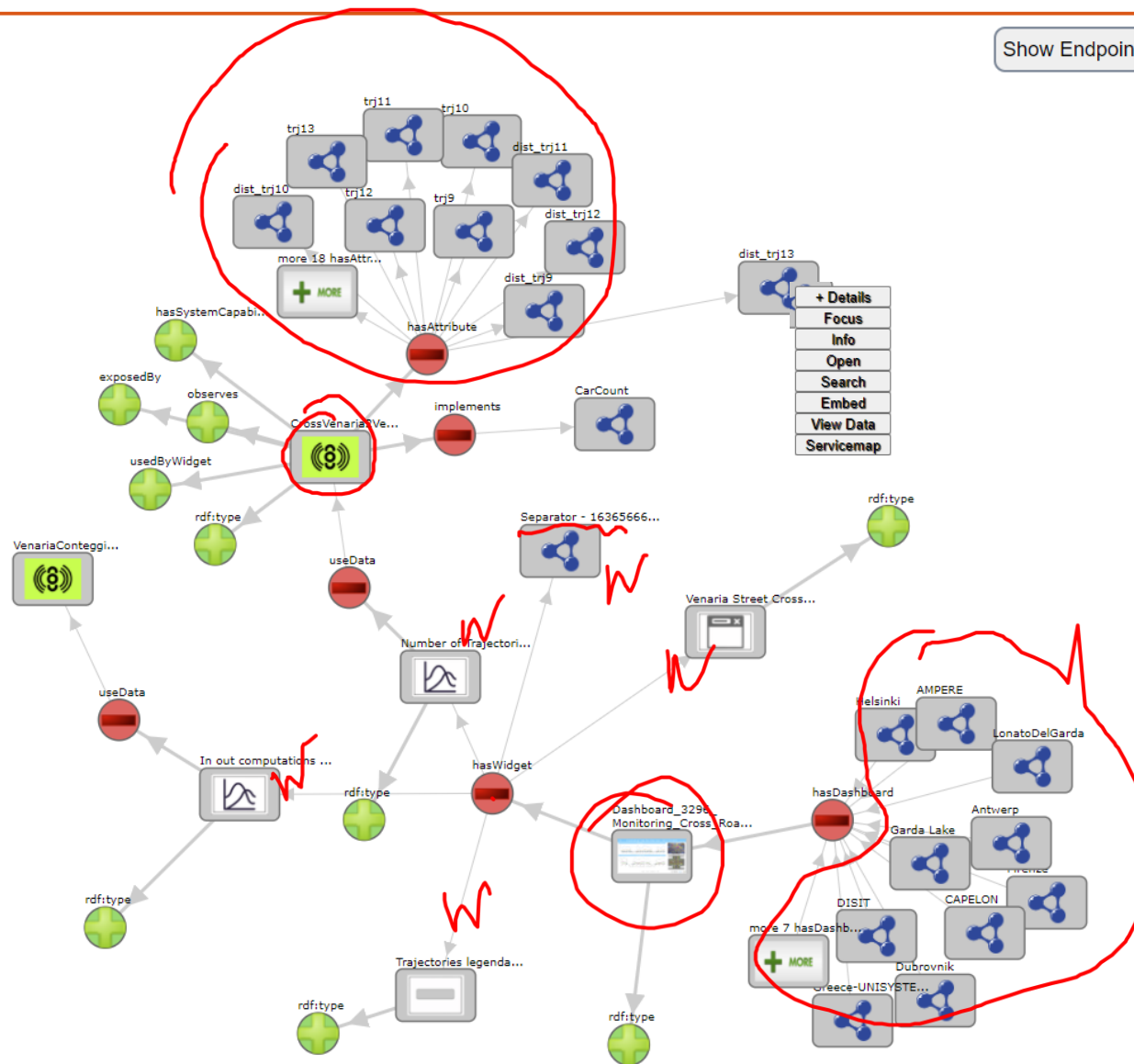



## Karlstad - Capelon

CAPELON

Sun 28 Nov 20:02:16

- Cabinet
- Smart Light
- Demo Lamp
- Smart Waste

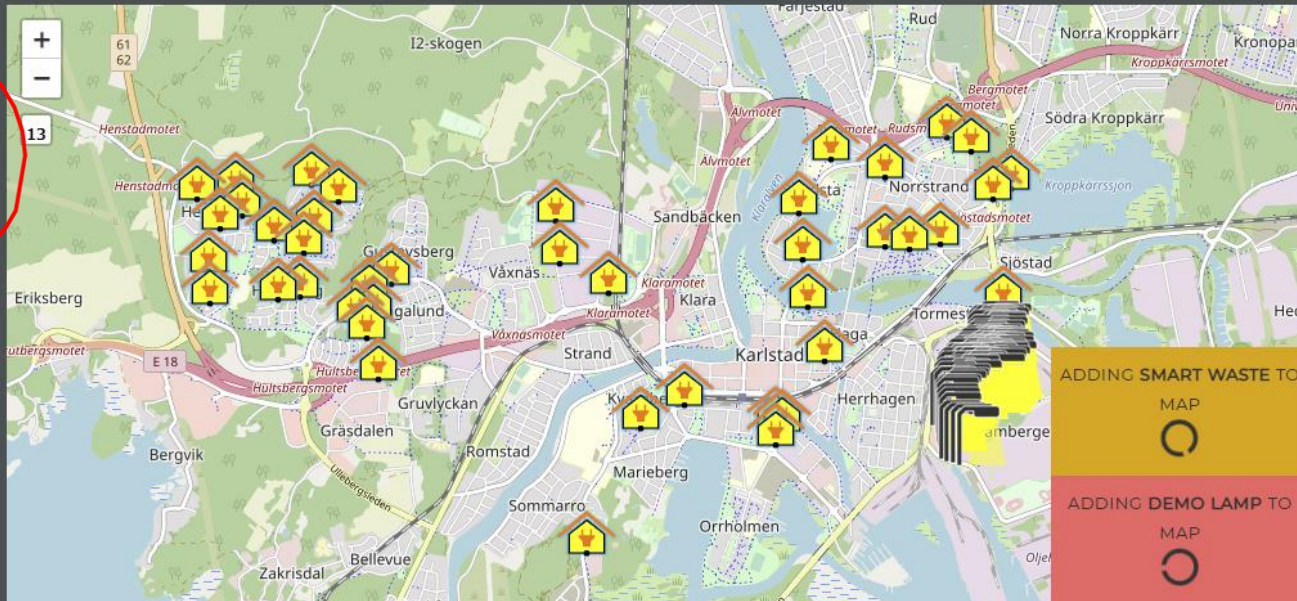

Lamp ON

Lamp OFF

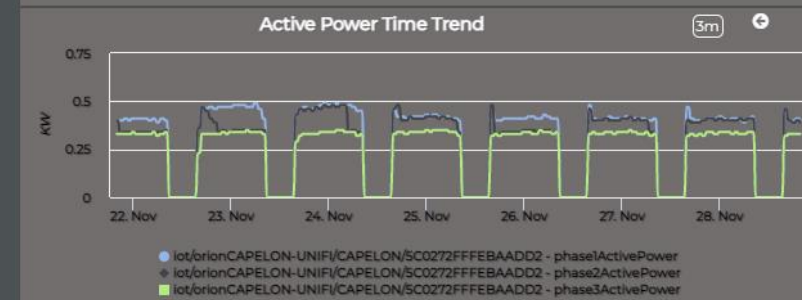
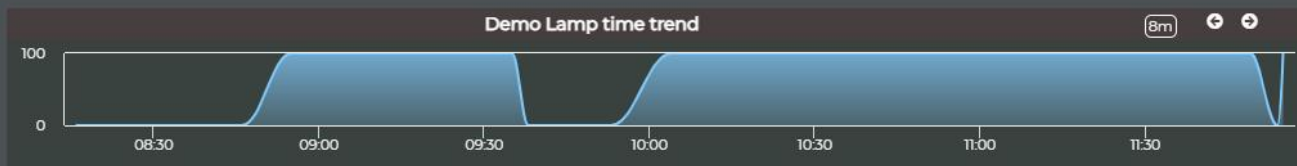

### Linked Open Graph

Shown: 45  
Entities: 31  
Relations: 14

Select a SPARQL endpoint:

Examples:  
uri:

Multiple endpoint search

---

**Your data**

sparql endpoint: (optional)

uri:

Multiple endpoint search

---

**Status**

Requests:

**Type of relations**

Select all  Deselect all  Invert  Hide all inverse

<input type="checkbox"/> foaf:depiction	<input checked="" type="checkbox"/> hasDashboard
<input checked="" type="checkbox"/> hasData	<input checked="" type="checkbox"/> hasIoTApp
<input checked="" type="checkbox"/> hasWidget	<input type="checkbox"/> owl:sameAs
<input type="checkbox"/> rdfs:type	<input checked="" type="checkbox"/> rdfs:seeAlso
<input checked="" type="checkbox"/> useData	<input checked="" type="checkbox"/> useIoTApp
<input checked="" type="checkbox"/> usedByWidget	<input checked="" type="checkbox"/> usedInDashboard

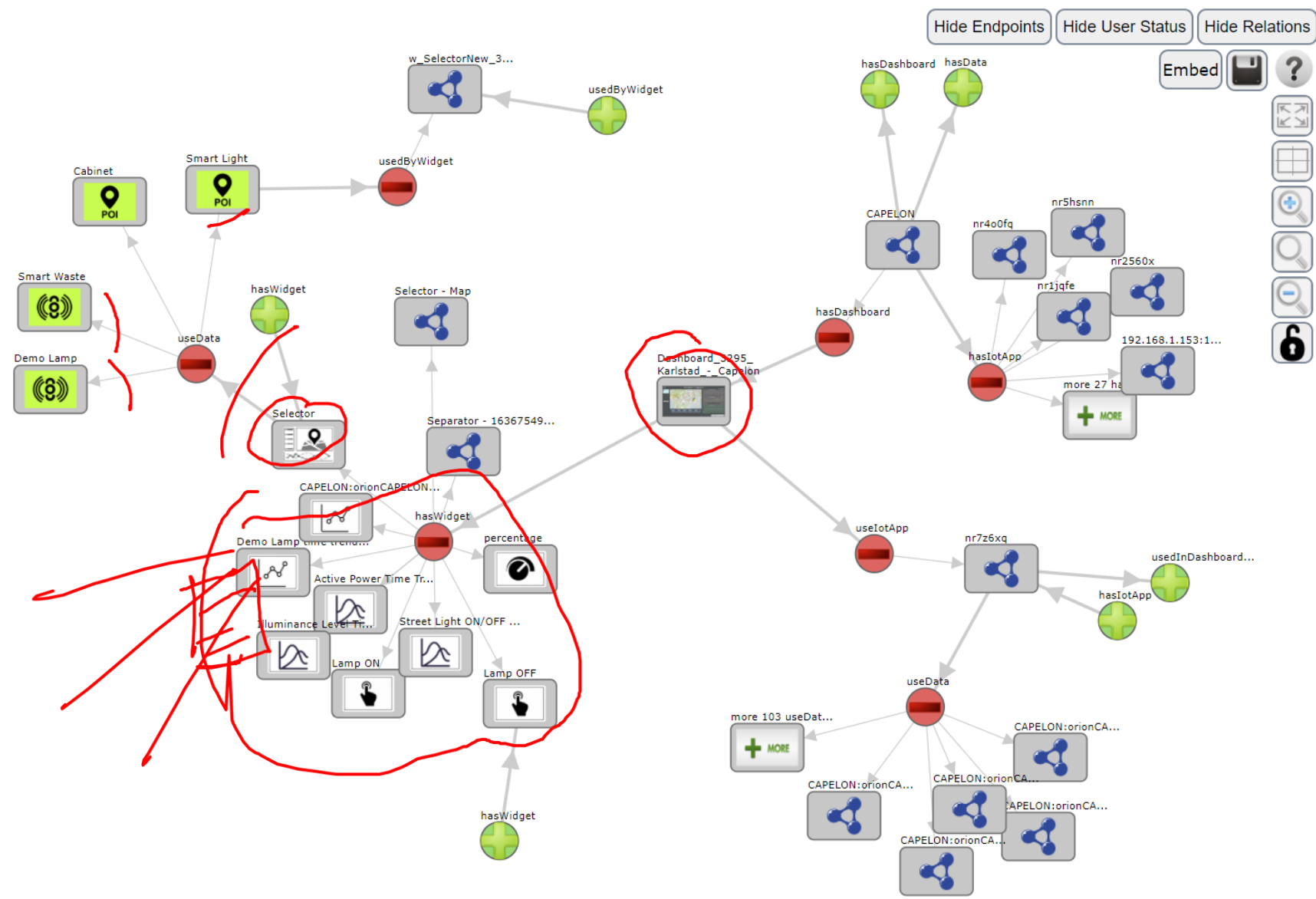

<https://www.snap4city.org/dashboardSmartCity/view/index.php?iddashboard=MTk2Mw==>

## Check Data Analytics Tuscany

Testing - Irene

Sun 28 Nov 22:43:30

### Air Quality

AirQualityNO2-Tuscany 9m

Interpolation and Heatmap Completed 2021-09-30T14:00:00

AirQualityPM10-Tuscany 9m

Interpolation and Heatmap Completed 2021-09-30T14:00:00

AirQualityPM2.5-Tuscany 9m

Interpolation and Heatmap Completed 2021-09-30T14:00:00

Tuscany CAQI 9m

Interpolation and EAQI/CAQI Heatmap Completed 2021-09-30T14:00:00

Tuscany EAQI 9m

Interpolation and EAQI/CAQI Heatmap Completed 2021-09-30T14:00:00

### Weather

AirHumidity-Tuscany 9m

Interpolation and Heatmap Completed 2021-09-05T02:00:00

AirQualityO3-Tuscany 9m

Interpolation and Heatmap Completed 2021-09-30T14:00:00

AirTemperature-Tuscany 9m

Interpolation and Heatmap Completed 2021-09-30T14:00:00

AirQualityCO-Tuscany 9m

Interpolation and Heatmap Completed 2021-09-30T14:00:00

[Privacy Policy](#) [Cookies Policy](#) [Terms and Conditions](#) [Contact us](#)

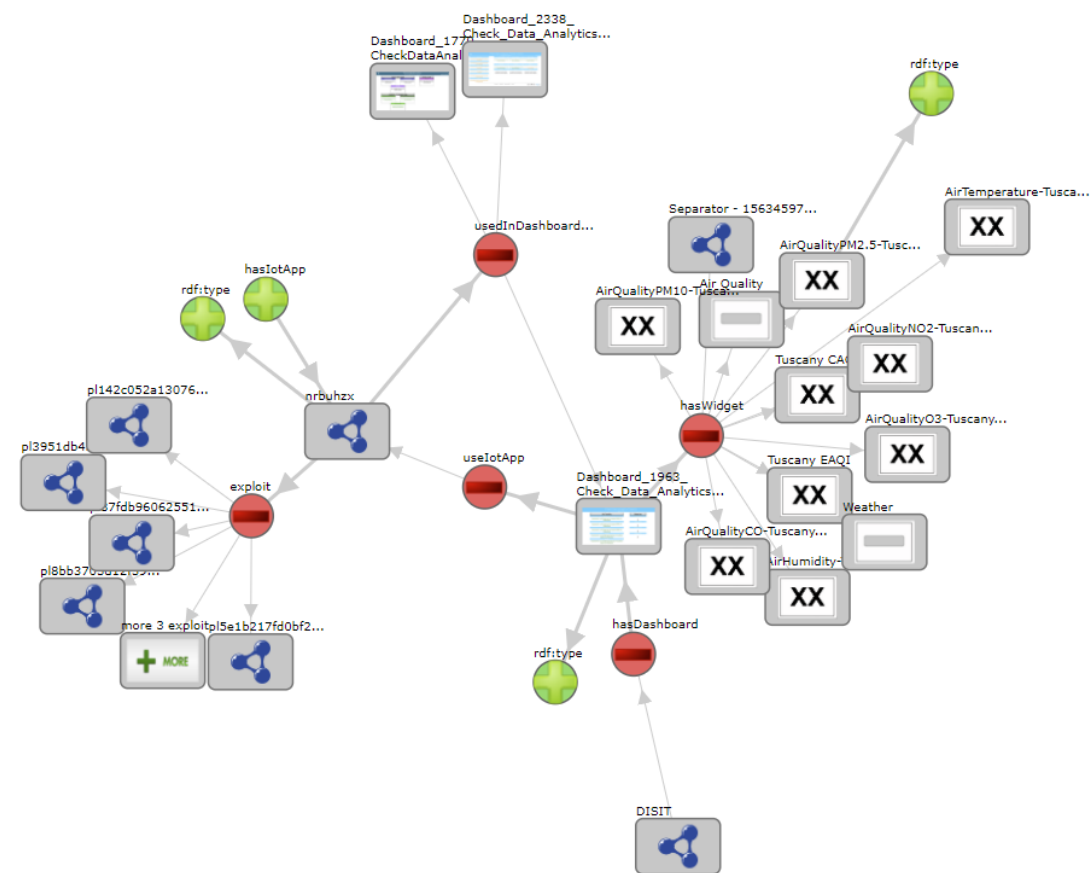



# What is missing here and you can get from former course

DATA GATHERING AND CITY DATA KNOWLEDGE MANAGEMENT

FORGING & MANAGING OPEN AND FLEXIBLE WEB AND MOBILE APPS

IOT APPLICATIONS VS. IT LOGIC DEVICES

IOT/IOE DEVICES AND NETWORKS

IOT APPLICATIONS, THE LOGIC AND THE SMARTNESS

ADVANCED SMART CITY API, MICROSERVICES, SNAP4CITY API

SNAP4CITY LIVING LAB FOR COLLABORATIVE WORK

SNAP4CITY FOR BEGINNERS

SNAP4CITY ARCHITECTURE AND ECOSYSTEM. OPENED TO DEVELOPERS AND MAKERS

DATA ANALYTICS, BUSINESS INTELLIGENCE, WHAT IS AND IS NOT SMART

TWITTER VIGILANCE: SOCIAL MEDIA ANALYSIS

HOW TO ADOPT SNAP4CITY, AND OUR ROADMAP

SNAP4CITY AND KM4CITY PROJECTS

SNAP4CITY THE VIEW OF THE ADMINISTRATORS

# What is missing here and you can find in the former course

<https://www.snap4city.org/577>

- Data Streams from partecipanti, Mobile App
- Data streams from Mobile vehicles and smart phones Devices
- Data Ingestion via Web Scraping
- Data stream from TV Cameras, TV Cam Manager
- From external API to Node-RED node/block automatically
- Social Media interoperability
- Another Complete Example
- BlockChain models and devices in Snap4City (new feature)
- Orion Broker:
  - Services/SrvPath and Multitenant
- External and Internal Brokers,
  - External Broker harvesting
- Managing Node-RED on edge from cloud
- More on: Security of Snap4City Stack from device to dashboards
- VM based installation of Snap4City
- ETL: Penthao Kettle interoperability

<https://www.snap4city.org/944>

*On Line Training Material (free of charge)*



1st part	2nd part	3rd part	4th part	5th part	6th part	7th part	8th
Overview	Dashboards	IOT App, IOT Network	Data Analytics	Data Ingestion processes	System and Deploy Install	Smart City API: Web & Mob. App	Design and Develop Smart Solutions





# Training Material



	1st part	2nd part	3rd part	4th part	5th part	6th part	7th part	8th
what	Overview	Dashboards	IOT App, IOT Network	Data Analytics	Data Ingestion processes	System and Deploy Install	Smart City API: Web & Mob. App	Design and Develop Smart Solutions
PDF 2022								
Interactive (2022) with video and animations								

# Note on Training Material

- **Course 2023:** <https://www.snap4city.org/944>
  - Introductionary course to Snap4City technology
- **Course** <https://www.snap4city.org/577>
  - Full training course with much more details on mechanisms and a wider set of cases/solutions of the Snap4City Technology
- **Documentation** includes a deeper round of details
  - Snap4City Platform Overview:
    - <https://www.snap4city.org/drupal/sites/default/files/files/Snap4City-PlatformOverview.pdf>
  - Development Life Cycle:
    - <https://www.snap4city.org/download/video/Snap4Tech-Development-Life-Cycle.pdf>
  - Client Side Business Logic:
    - <https://www.snap4city.org/download/video/ClientSideBusinessLogic-WidgetManual.pdf>
- **On line cases and documentation:**
  - <https://www.snap4city.org/108>
  - <https://www.snap4city.org/78>
  - <https://www.snap4city.org/426>

[Switch To New Layout \(Beta\)](#)User: paolo.disit, Org: DISIT  
Role: AreaManager, Level: 3[LOGOUT](#) [Home](#) / [Tutorials and Videos](#) / Welcome: how to start using Snap4City for beginners

## Welcome: how to start using Snap4City for beginners





### We suggest you:

Congratulations! You have really contributed to Snap4City and successfully passed all first levels!

You have reached a level in which you can contribute with competence to the city improvement and smartness. We hope you interested in helping other users in conquering higher levels on the city smartness ranking, and provising of smart services to all city users!

So that we could be interested in engaging and elevating your role in the Snap4City community as coordinator of thematic groups, for example on **Mobile APP development**, **Dashboard on Mobility**, **IOT Application Development**, etc., according to your preferences.

Please contact [paonesi@gmail.com](mailto:paonesi@gmail.com) !

[+ Share / Save](#)    ...[Add to your favorites](#)

Innovations



Interoperability



Installations



What People say



Mobile Apps



IOT Devices



IOT Applications



Data Analytics



Dashboards



Living Lab



Smart City API



Smart City Ontology



Work with Us



Articles



SNAP4CITY on EUROPEAN OPEN SCIENCE CLOUD MARKETPLACE



SNAP4CITY HACKATHON



INDUSTRY 4.0



Snap4Industry



Snap4Home

- TECHNICAL OVERVIEW: <https://www.snap4city.org/download/video/Snap4City-PlatformOverview.pdf>
- Development Life Cycle: <https://www.snap4city.org/download/video/Snap4Tech-Development-Life-Cycle.pdf>
- Client-Side Business Logic Widget Manual: <https://www.snap4city.org/download/video/ClientSideBusinessLogic-WidgetManual.pdf>
- Booklet Data Analytics, Snap4Solutions: [https://www.snap4city.org/download/video/DPL\\_SNAP4SOLU.pdf](https://www.snap4city.org/download/video/DPL_SNAP4SOLU.pdf)

Please start a fully guided training cases:

- [HOW TO: create a Dashboard in Snap4City](#)
- [HOW TO: add a device to the Snap4City Platform](#)
- [HOW TO: add data sources to the Snap4City Platform](#)

Username: paolo.disit

## Search

**Training on Tools and Platform**Powered by  
[www.km4city.org](http://www.km4city.org)

## Organization Groups

DISIT

- Developer
- Operativo

## Updates on Tools

Training Course Snap4City - 2023 Edition **new**  
drupaladminSnap4City Newsletter of April 2023 **new**  
roottooladmin1[My Snap4City.org](#)[Tour Again](#)[www.snap4solutions.org](#)[Dashboards \(Public\)](#)[Dashboards of My Organization](#)[My Dashboards in My Organization](#)[My Data Dashboard Dev Kibana](#)[Extra Dashboard Widgets](#)[Data Management, HLT](#)[Knowledge and Maps](#)[Processing Logics / IOT App](#)[Entity Directory and Devices](#)[Resource Manager](#)[Development Tools](#)[Management](#)[Decision Support Systems](#)[Deploy and Installation](#)[Help and Contacts](#)[Documentation and Articles](#)[My Profile](#)[Km4City portal](#)[DISIT Lab portal](#)



Home / Snap4City: Smart aNalytic APp builder for sentient Cities and IOT

# Snap4City: Smart aNalytic APp builder for sentient Cities and IOT

You can't delete this newsletter because it has not been sent to all its subscribers.

Username: paolo.disit

## Search

Search    
-Any-

**WHAT IS Snap4City**

**SMARTCITY EXPO WORLD CONGRESS**  
15 - 17 NOVEMBER 2022  
BARCELONA & ONLINE [GET YOUR PASS](#)

**Articles**

**LATEST NEWS**

**SELECT for CISEN**  
1<sup>o</sup> Place award to **SNAP4CITY**

**Snap4City Training on Tools and Platform**

**Flyer**

**SNAP4CITY on EUROPEAN OPEN SCIENCE CLOUD MARKETPLACE**

**SNAP4CITY HACKATHON**  
BUILD YOUR APP FOR A CONNECTED CITY

**INDUSTRY 4.0**  
Snap4Industry

**SMART**  
Snap4Home

**Organizations**

**Tutorials**

**Scenarios**

**Innovations**

**Interoperability**

**Installations**

**API**  
Smart City API

**Ontology**  
Smart City Ontology

**Work with Us**

**Training on Tools and Platform**

Powered by [www.km4city.org](#)

**FIWARE**

**Node-RED**

**Sii-Mobility**

**Organization Groups**

DISIT

- Developer
- Operativo

- TECHNICAL OVERVIEW: <https://www.snap4city.org/download/video/Snap4City-PlatformOverview.pdf>
- Development Life Cycle: <https://www.snap4city.org/download/video/Snap4Tech-Development-Life-Cycle.pdf>
- Client-Side Business Logic Widget Manual: <https://www.snap4city.org/download/video/ClientSideBusinessLogic-WidgetManual.pdf>
- Booklet Data Analytics, Snap4Solutions: [https://www.snap4city.org/download/video/DBL\\_SNAP4SOLU.pdf](https://www.snap4city.org/download/video/DBL_SNAP4SOLU.pdf)

## Updates on

# booklets

- Smart City



[https://www.snap4city.org/download/video/DPL\\_SNAP4CITY.pdf](https://www.snap4city.org/download/video/DPL_SNAP4CITY.pdf)

- Industry



[https://www.snap4city.org/download/video/DPL\\_SNAP4INDUSTRY.pdf](https://www.snap4city.org/download/video/DPL_SNAP4INDUSTRY.pdf)

- Artificial Intelligence



[https://www.snap4city.org/download/video/DPL\\_SNAP4SOLU.pdf](https://www.snap4city.org/download/video/DPL_SNAP4SOLU.pdf)

# The Platform

- **Free Registration on Snap4City.org**
  - Please select DISIT ORG to be sure to access at the examples
  - Most of the cities / tenant are private and they do not left much visible
- **What you get** is probably the 10% of what is on the platform 😊
- **Training:** <https://www.snap4city.org/577>
- **Scenarious:** <https://www.snap4city.org/4>
- **Publications:** <https://www.snap4city.org/426>
- **WEB pages:** <https://www.snap4city.org/78>
- ***SEARCH on the right side***

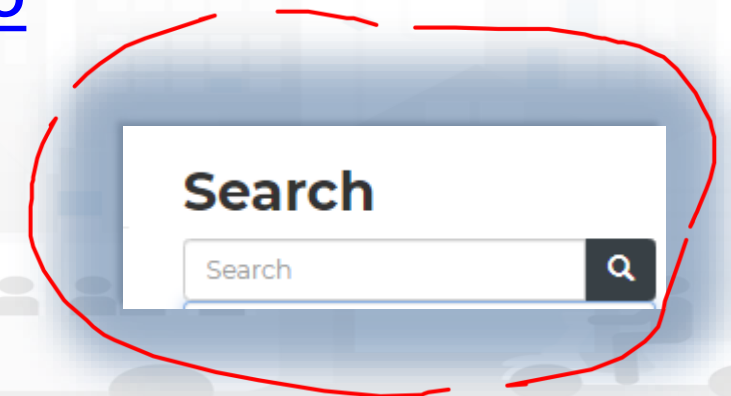

### Technical Overview

From: DINFO dept of University of Florence, with its  
DISIT Lab, <https://www.disit.org> with its Snap4City solution

Snap4City:

- Web page: <https://www.snap4city.org>
- <https://twitter.com/snap4city>
- <https://www.facebook.com/snap4city>

Contact Person: Paolo Nesi, [Paolo.nesi@unifi.it](mailto:Paolo.nesi@unifi.it)

- Phone: +39-335-5668674
- LinkedIn: <https://www.linkedin.com/in/paolo-nesi-849ba51/>
- Twitter: <https://twitter.com/paolonesi>
- FaceBook: <https://www.facebook.com/paolo.nesi2>

# Tech. Overview

- <https://www.snap4city.org/drupal/sites/default/files/files/Snap4City-PlatformOverview.pdf>



# Development

<https://www.snap4city.org/download/video/Snap4Tech-Development-Life-Cycle.pdf>



## Development Life-Cycle

<https://www.snap4city.org/download/video/Snap4Tech-Development-Life-Cycle-v1-1.pdf>

### From Snap4City:

- We suggest you to read the **TECHNICAL OVERVIEW**:
  - <https://www.snap4city.org/download/video/Snap4City-PlatformOverview.pdf>
- <https://www.snap4city.org>
- <https://www.snap4solutions.org>
- <https://www.snap4industry.org>
- <https://twitter.com/snap4city>
- <https://www.facebook.com/snap4city>
- <https://www.youtube.com/channel/UC3tAO09EbNba8f2-u4vandq>

**Coordinator:** Paolo Nesi, [Paolo.nesi@unifi.it](mailto:Paolo.nesi@unifi.it)

DISIT Lab, <https://www.disit.org>  
DINFO dept of University of Florence,  
Via S. Marta 3, 50139, Firenze, Italy  
Phone: +39-335-5668674



# Client Side Business Logic

<https://www.snap4city.org/download/video/ClientSideBusinessLogic-WidgetManual.pdf>



## Client-Side Business Logic Widget Manual

### From Snap4City:

- We suggest you read <https://www.snap4city.org/download/video/Snap4Tech-Development-Life-Cycle.pdf>
- We suggest you read the TECHNICAL OVERVIEW:
  - <https://www.snap4city.org/download/video/Snap4City-PlatformOverview.pdf>
- slides go to <https://www.snap4city.org/577>
- <https://www.snap4city.org>
- <https://www.snap4solutions.org>
- <https://www.snap4industry.org>
- <https://twitter.com/snap4city>
- <https://www.facebook.com/snap4city>
- <https://www.youtube.com/channel/UC3tAQ09EbNba8f2-u4vanda>

Coordinator: Paolo Nesi, [Paolo.nesi@unifi.it](mailto:Paolo.nesi@unifi.it)  
DISIT Lab, <https://www.disit.org>  
DINFO dept of University of Florence,  
Via S. Marta 3, 50139, Firenze, Italy  
Phone: +39-335-5668674



# Commercial Overview



- <https://fiware-foundation.medium.com/snap4-city-fiware-powered-smart-app-builder-for-sentient-cities-acfe24df49d5>
- [https://www.snap4city.org/drupal/sites/default/files/files/FF\\_ImpactStories\\_Snap4City.pdf](https://www.snap4city.org/drupal/sites/default/files/files/FF_ImpactStories_Snap4City.pdf)

Open APIs for Open Minds

SMART CITIES AND SMART INDUSTRY

**Snap4City:**  
**FIWARE powered smart app  
builder for sentient cities**

With the contribution of

TOP

FORGING & MANAGING OPEN AND FLEXIBLE WEB AND MOBILE APPS

FROM CITY DASHBOARD TO APPLICATIONS

DATA GATHERING AND CITY DATA KNOWLEDGE MANAGEMENT

IOT APPLICATIONS VS IOT EDGE DEVICES

IOT APPLICATIONS, THE LOGIC AND THE SMARTNESS

ADVANCED SMART CITY API, MICROSERVICES, SNAP4CITY API

SNAP4CITY LIVING LAB FOR COLLABORATIVE WORK

SNAP4CITY FOR BEGINNERS

WHAT-IF AND SIMULATION

SNAP4CITY ARCHITECTURE AND ECOSYSTEM. OPENED TO DEVELOPERS AND STAKEHOLDERS

TWITTER VIGILANCE SOCIAL MEDIA ANALYSIS

DECISION SUPPORT SYSTEM AND CITY RESILIENCE

HOW TO ADOPT SNAP4CITY, AND OUR ROADMAP

SNAP4CITY AND KM4CITY PROJECTS

SNAP4CITY THE VIEW OF THE ADMINISTRATORS

# Acknowledgements

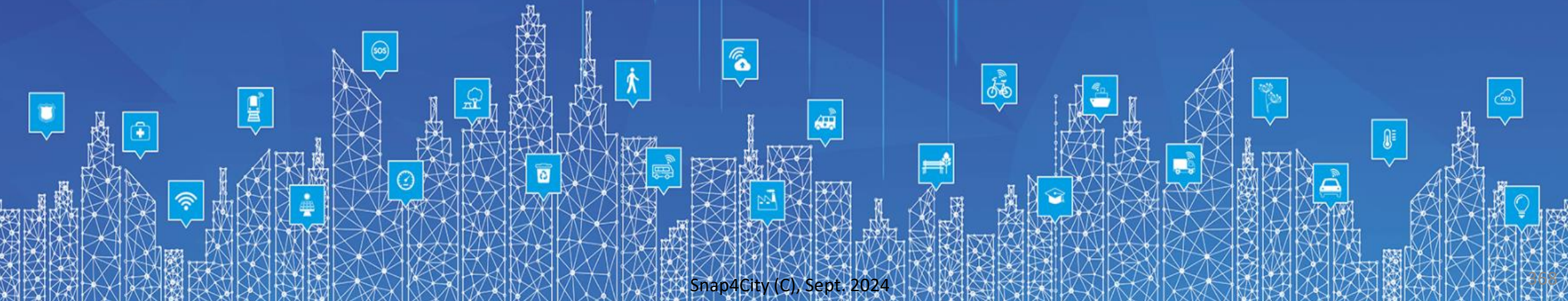

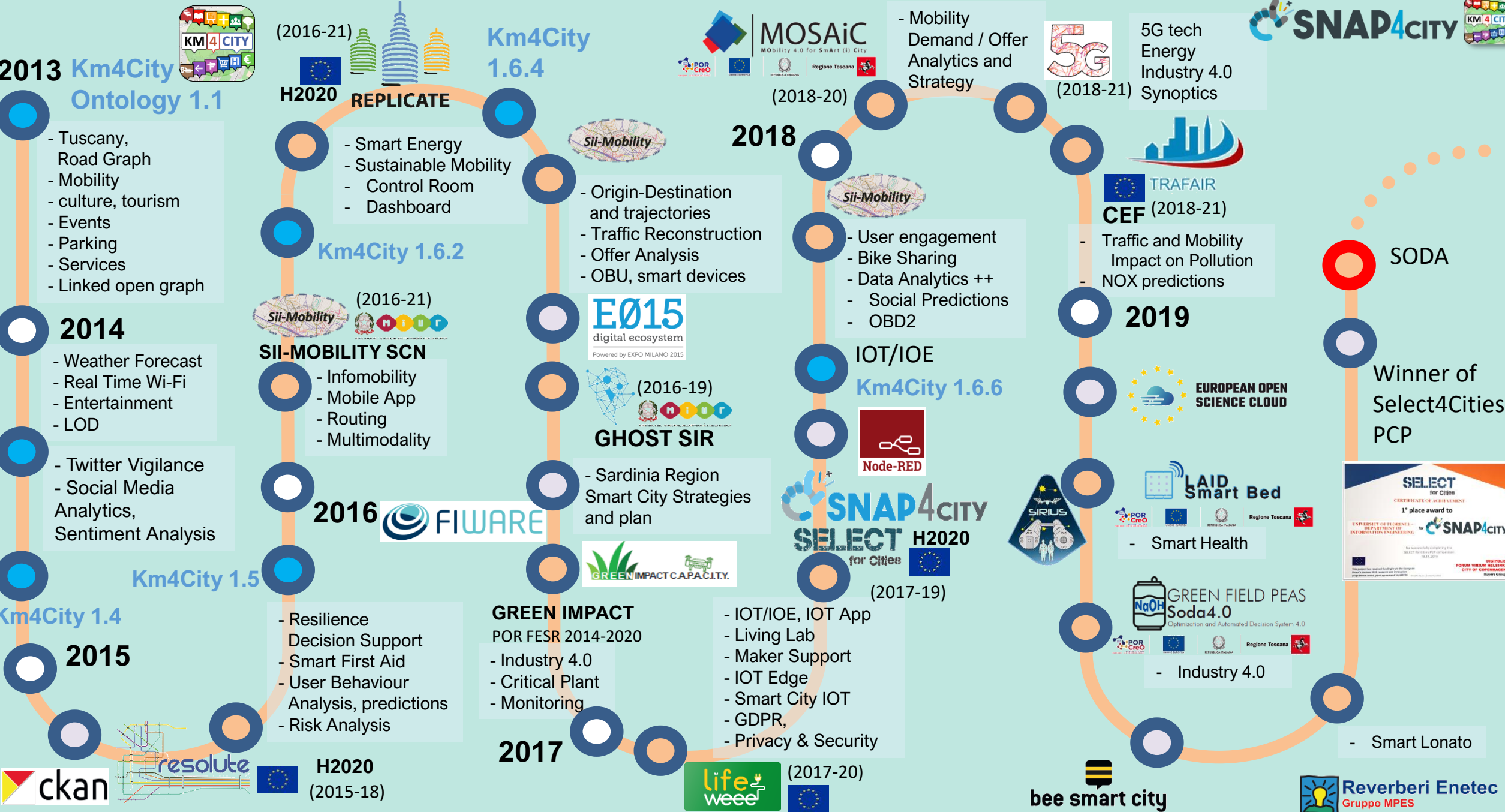

**2013 Km4City Ontology 1.1**

- Tuscany, Road Graph
- Mobility
- culture, tourism
- Events
- Parking
- Services
- Linked open graph

**2014**

- Weather Forecast
- Real Time Wi-Fi
- Entertainment
- LOD

- Twitter Vigilance
- Social Media Analytics, Sentiment Analysis

**Km4City 1.4**

**2015**

- Resilience Decision Support
- Smart First Aid
- User Behaviour Analysis, predictions
- Risk Analysis



**(2016-21) H2020 REPLICATE Km4City 1.6.4**

- Smart Energy
- Sustainable Mobility
- Control Room
- Dashboard

**Km4City 1.6.2**

- (2016-21) SII-MOBILITY SCN**
- Infomobility
  - Mobile App
  - Routing
  - Multimodality

**2016 FIWARE**

- GREEN IMPACT**  
POR FESR 2014-2020
- Industry 4.0
  - Critical Plant
  - Monitoring



**MOSAIC (2018-20)**

- Origin-Destination and trajectories
- Traffic Reconstruction
- Offer Analysis
- OBU, smart devices

**E015 digital ecosystem**  
Powered by EXPO MILANO 2015

**(2016-19) GHOST SIR**

- Sardinia Region Smart City Strategies and plan

**SNAP4CITY SELECT H2020 for Cities (2017-19)**

- IOT/IOE, IOT App
- Living Lab
- Maker Support
- IOT Edge
- Smart City IOT
- GDPR, Privacy & Security



**2018**

- User engagement
- Bike Sharing
- Data Analytics ++
- Social Predictions
- OBD2

**IOT/IOE Km4City 1.6.6**



**SNAP4CITY SELECT H2020 for Cities (2017-19)**

- Smart Waste

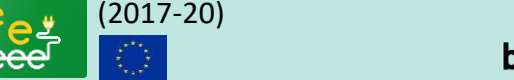

**- Mobility Demand / Offer Analytics and Strategy (2018-21)**

- Traffic and Mobility Impact on Pollution
- NOX predictions

**2019**

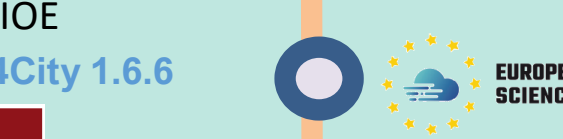

- Smart Health

- Industry 4.0



**SODA**

Winner of Select4Cities PCP



**DISIT lab roadmap vs model and tools' usage**



**2020**



- Smart Tourism
- 6 Pilots
- Data Analytics
- Extended platform



- Smart Mobility
- PISA, PUMS
- Living lab



**Km4City 1.6.7**

Smart Ambulance (2021-22)

Enterprise (2021-22)  
Industry 4.0



Contract

**2021**

PC4City (2020-21)  
Monitoring Terrain

Winner of Open Data Challenge of  
**enel x**

**CAPĒLON**

- Smart Light
- Sweden

Almafluida Industry 4.0 (2021-22)

AMPERE (2021-22)  
Industry 4.0

SYN-RG-AI  
SmartCity



Industry 4.0

**uni.systems**

SmartCity, 2021-23



AXIS collab  
SmartCity

**2022**



Asymmetrica  
Smart City, 2022-23

Contract, 2022-23



**2023**



Contract, 2022-23



2022-2023



Security and Risk



Italferr, Smart City

CN MOST, 2022-26



EI THE, 2022-26



G. Agile, 2021-23



2023-26



Merano, smart light

OceanRace,  
Genova, AWS

Cuneo,  
smart city

**2024**

TOURISMO



Co-funded by  
the European Union



AMMIRARE

ELLIE IA  
2025-2027



Contract, 2024-25

CAI4DSA



OPTIFaaS



SASUAM



Rhodes,  
smart city

eShare  
UNIFI TUSS



PEN Test  
Passed



EU GDPR  
COMPLIANT



- 11 running installations in Europe
  - Snap4.city.org, Greece, Merano, Cuneo, ...
  - Toscana, Pisa, Sweden, ISPRA, Snap4.eu,
  - Altair, Italmatic, Romania, ....

- 16 projects, 12 pilots on 10 Countries
  - >40 cities/area

## • Widest MULTI-tenant deploy has

- 24 Organizations / tenant
- > 8850 users on
- > 1800 Dashboards
- > 17 mobile Apps
- > **2.2 Million of structured data per day**
- > 580 IoT Applications/node-RED
- > 750 web pages with training
- > 75 videos, training videos

### Main Organizations/areas

- [Antwerp area \(Be\)](#)
- [Bari \(I\)](#)
- [Bisevo, Croatia](#)
- [Bologna \(I\)](#)
- [Brasov \(Ro\)](#), by ICEBERG
- [Capelon \(Sweden: Västerås, Eskilstuna, Karlstad\)](#)
- [Cuneo \(I\)](#)
- [DISIT demo \(multiple\)](#)
- [Dubrovnik, Croatia](#)
- [Firenze area \(I\)](#)
- [Garda Lake area \(I\)](#)
- [Greece \(Gr\)](#)
- [Helsinki area \(Fin\)](#)
- [Limassol \(Cy\)](#)
- [Livorno area \(I\)](#)
- [Lonato del Garda \(I\)](#)
- [Malta \(Malta\)](#)
- [Merano \(I\)](#)
- [Modena \(I\)](#)
- [Mostar, Bosnia-Herzegovina](#)
- [Oslo & Padova \(Impetus\)](#)
- [Pisa area \(I\)](#)
- [Pistoia \(I\)](#)
- [Pont du Gard, Occitanie \(Fr\)](#)
- [Prato \(I\)](#)
- [Rhodes \(Gr\)](#)
- [Roma \(I\)](#)
- [Santiago de Compostela \(S\)](#)
- [Sardegna Region \(I\)](#)
- [Siena \(I\)](#)
- SmartBed (multiple)
- [Toscana Region \(I\), SM](#)
- [Valencia \(S\)](#)
- [Venezia area \(I\)](#)
- [WestGreece area \(Gr\)](#)

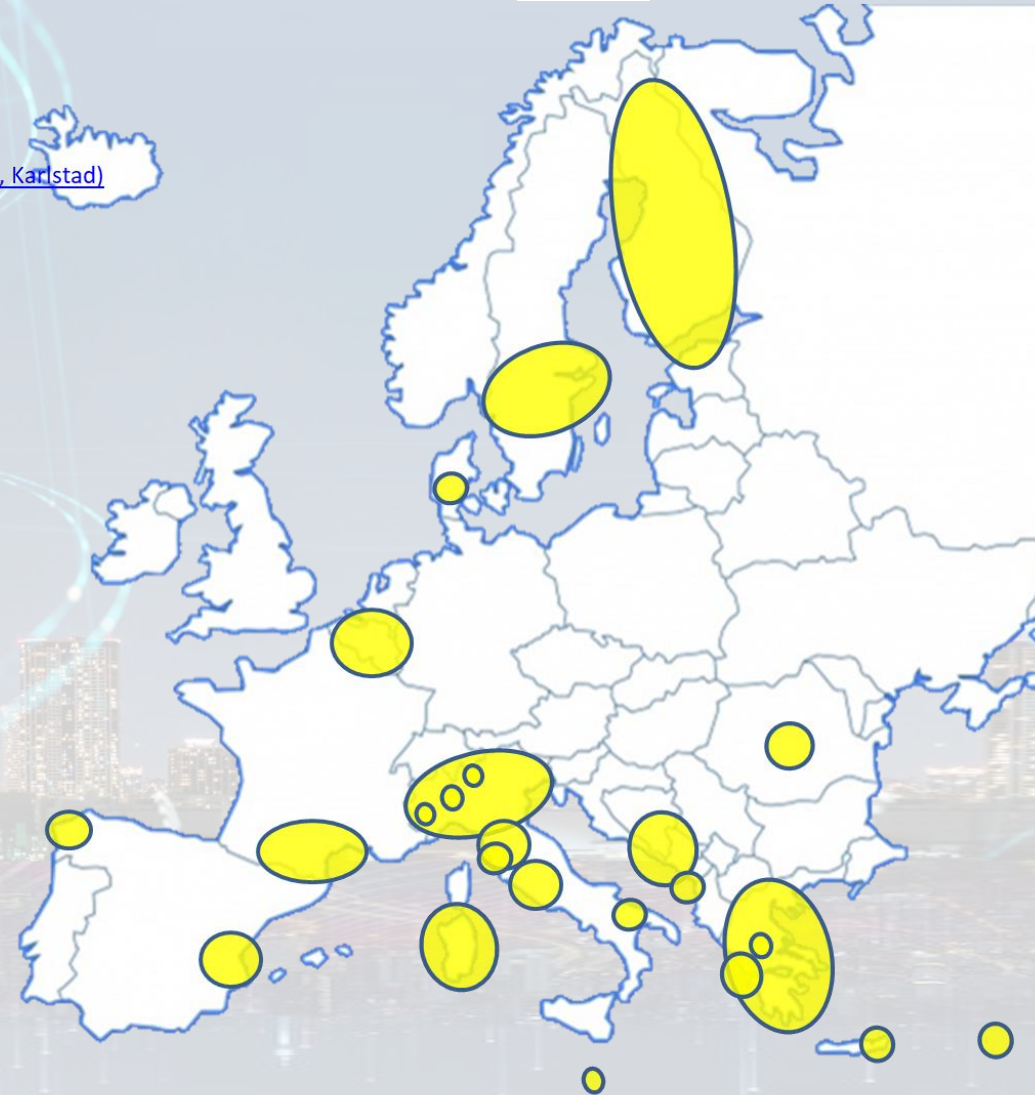

- + Israel, Colombia, Brasile, Australia, India, China, etc.

TOP



*Be smart in a SNAP!*



## CONTACT

DISIT Lab, DINFO: Department of Information Engineering  
Università degli Studi di Firenze - School of Engineering

Via S. Marta, 3 - 50139 Firenze, ITALY  
<https://www.disit.org>

[www.snap4city.org](http://www.snap4city.org)

 **SNAP4**  
Appliances and Dockers  
**Installations**

Email: [snap4city@disit.org](mailto:snap4city@disit.org)

Office: +39-055-2758-515 / 517

Cell: +39-335-566-86-74

Fax.: +39-055-2758570



UNIVERSITÀ  
DEGLI STUDI  
FIRENZE

**DINFO**  
DIPARTIMENTO DI  
INGEGNERIA  
DELL'INFORMAZIONE

**DISIT**  
DISTRIBUTED SYSTEMS  
AND INTERNET  
TECHNOLOGIES LAB